

# **ENGINEERING DESIGN STANDARDS**

2023 Edition



## ENGINEERING DESIGN STANDARDS

THE CORPORATION OF THE MUNICIPALITY OF THAMES CENTRE  
Revisions

### Revisions

The following table summarizes the revisions to this manual since its preparation on June 14, 2021. Please ensure your manual is up-to-date and you have all the revisions.

<b>Revisions (MM-DD-YYYY)</b>	<b>Modification and Commentary</b>	<b>Subsections/Figures Modified</b>
03/23/2023	Replaced the 2021 Edition with 2023 Edition - Page Re-numbering/ minor specification updates, minor drawing revisions/ additions/ removals.	2021 Edition will be available for reference until 2024. 2023 Edition will come into full force at the start of 2024.
04/20/2026	Typographical errors have been corrected and wording refined to align with proper engineering practices and standards.	4.4.3.4, 5.5.1, 7.7.1,

## Table of Contents

<b>REVISIONS .....</b>	<b>2</b>
<b>1.0 INTRODUCTION.....</b>	<b>11</b>
1.1 THAMES CENTRE.....	11
1.2 PURPOSE OF DESIGN CRITERIA.....	11
1.3 LIST OF CONTACTS .....	11
1.4 ENGINEER'S ROLE.....	12
1.5 BARRIER FREE CONSIDERATIONS .....	12
<b>2.0 GENERAL REQUIREMENTS .....</b>	<b>13</b>
2.1 SUPPORTING STUDIES AND REPORTS.....	13
2.2 APPROVAL AGENCIES.....	14
2.2.1 Subdivision Approval.....	14
2.2.2 Site Plan Approval.....	17
2.3 DRAFTING REQUIREMENTS.....	18
2.3.1 Drawing Standards.....	18
2.3.2 Engineering Drawings .....	18
2.4 CAD/GIS ASSET MANAGEMENT REQUIREMENTS .....	22
2.4.1 Civil 3D – AutoCAD.....	22
2.4.2 Georeferencing .....	22
2.5 AS-BUILT/RECORD DRAWING REQUIREMENTS .....	23
2.5.1 Final Submission.....	23
2.5.2 Recording of PDC Services.....	23
2.6 DEVELOPMENT CHARGES.....	24
2.7 COST ESTIMATE AND PROJECT SCHEDULE .....	24
2.7.1 Schedules for Subdivision Agreement.....	24
2.8 OPERATION AND MAINTENANCE REQUIREMENTS.....	24
<b>3.0 STORM COLLECTION SYSTEM.....</b>	<b>25</b>
3.1 GENERAL .....	25
3.2 PERMITTED USES .....	25
3.3 LOCATION AND ALIGNMENT .....	25
3.3.1 Storm Sewers on Private Property .....	25
3.4 DRAINAGE/SUBDRAINAGE AREA PLANS.....	25
3.5 EXTERNAL WATERSHED LIMITS AND DRAINAGE AREAS.....	26
3.6 DESIGN CRITERIA.....	26
3.6.1 Design Chart.....	26
3.6.2 Sewer Peak Flows .....	26
3.6.3 Sewer Capacity.....	27
3.6.4 Flow Velocity.....	28
3.7 PIPE MATERIAL .....	28
3.8 PIPE DEPTH AND BEDDING MATERIAL.....	29

3.8.1	Minimum Depth of Cover.....	29
3.8.2	Maximum Depth of Cover.....	29
3.8.3	Crossing Clearances.....	29
3.8.4	Minimum Distance Between Sewers .....	30
3.8.5	Trenchless Technologies .....	30
3.9	<b>MAINTENANCE HOLES .....</b>	<b>30</b>
3.9.1	Maintenance Hole Spacing .....	30
3.9.2	Precast Maintenance Hole Sizing Criteria .....	30
3.9.3	Maintenance Holes .....	30
3.9.4	Maintenance Hole Frame and Cover.....	31
3.9.5	Lockable Maintenance Hole Cover.....	31
3.9.6	Maintenance Hole Steps .....	31
3.9.7	Maintenance Hole Drop Structures .....	31
3.9.8	Maintenance Hole Safety Landings.....	31
3.9.9	Benching.....	32
3.9.10	Steps in Benching .....	32
3.9.11	Adjustment Units.....	32
3.9.12	Head losses .....	32
3.9.13	Maintenance Hole Construction Practices .....	34
3.9.14	Sampling/Inspection Maintenance Holes.....	35
3.10	<b>PRIVATE DRAIN CONNECTIONS (PDCS).....</b>	<b>35</b>
3.10.1	Location .....	35
3.10.2	Minimum Size and Grade.....	35
3.10.3	Connections to Sewers/Maintenance Holes .....	36
3.10.4	Vertical Clearance.....	36
3.10.5	PDC Detail .....	36
3.10.6	PDC Cleanouts .....	37
3.10.7	PDC Construction, Records and Markings .....	37
3.11	<b>CATCH BASINS.....</b>	<b>37</b>
3.11.1	Location .....	37
3.11.2	Minimum Lead Diameter and Grade.....	37
3.11.4	Depth of Cover.....	38
3.11.5	Allowable Ponding.....	38
3.11.6	Requirements for Length of Catch Basin Leads .....	39
3.11.7	Catch Basin Frame and Grates .....	39
3.11.8	Catch Basin Steps.....	39
3.11.9	Catch Basin Connections .....	39
3.11.10	Maintenance Hole Adjustment Unit .....	40
3.11.11	Catch Basin Lead Material .....	40
3.11.12	Catch Basin Subdrains.....	40
3.12	<b>STORM SEWER INLET AND OUTLET STRUCTURES HEADWALLS .....</b>	<b>40</b>
3.12.1	Types of Headwalls.....	40
3.12.2	Baffled Posts.....	41
3.12.3	Grill/Grates.....	41
3.12.4	Railing.....	41
3.12.5	Rip/Rap Rock Protection .....	41

3.13	EASEMENTS .....	42
<b>4.0</b>	<b>STORMWATER MANAGEMENT.....</b>	<b>43</b>
4.1	GENERAL .....	43
4.1.1	Background Information .....	43
4.1.2	SWM Checklists .....	43
4.1.3	Agency Approvals .....	44
4.2	SURFACE WATER CONSIDERATIONS.....	44
4.2.1	Water Quality Control Objectives .....	44
4.2.2	Erosion Control Objectives.....	46
4.2.3	Minor and Major Systems.....	46
4.3	HYDROGEOLOGICAL CONSIDERATIONS .....	47
4.3.1	Hydrogeological Assessment Requirements .....	47
4.3.2	Water Balance Requirements.....	48
4.4	DESIGN REQUIREMENTS .....	49
4.4.1	Catchment Delineation.....	49
4.4.2	Overland Flow Routes.....	50
4.4.3	Hydrologic Modeling.....	50
4.5	STORMWATER PRACTICES .....	53
4.5.1	Low Impact Development.....	53
4.5.2	Oil Grit Separators (OGS) .....	59
4.5.3	Design of Municipal SWM Ponds .....	60
4.6	OPERATION AND MAINTENANCE .....	65
4.7	DESIGN REFERENCES .....	65
4.7.1	General Stormwater Design References .....	65
4.7.2	Stormwater Engineering Checklists.....	66
<b>5.0</b>	<b>SANITARY COLLECTION SYSTEM.....</b>	<b>69</b>
5.1	GENERAL .....	69
5.2	DRAINAGE/SUB-DRAINAGE AREA PLANS.....	69
5.3	DESIGN CHART .....	69
5.4	PEAKING FACTOR CALCULATION .....	70
5.5	DESIGN CRITERIA.....	70
5.5.1	Tributary areas less than 200 ha .....	70
5.5.2	Peak Flow Calculation.....	71
5.5.3	Manning's Roughness Coefficient .....	72
5.5.4	Pipe Size.....	72
5.5.5	Flow Velocity .....	72
5.5.6	Minimum Grades.....	72
5.6	PIPE MATERIAL .....	73
5.7	PIPE DEPTH AND BEDDING MATERIAL.....	73
5.7.1	Minimum .....	73
5.7.2	Maximum Depth of Cover/Pipe Strength Design .....	73
5.7.3	Crossing Clearances.....	74
5.7.4	Minimum Distance between Wastewater Pipes.....	74

5.7.5	Trenchless Technologies .....	74
5.8	<b>MAINTENANCE HOLES .....</b>	<b>75</b>
5.8.1	Spacing of Maintenance Holes .....	75
5.8.2	Lockable Maintenance Hole Covers .....	76
5.8.3	Maintenance Hole Steps .....	76
5.8.4	Maintenance Hole Drop Structures .....	77
5.8.5	Maintenance Hole Safety Landings .....	77
5.8.6	Benching .....	77
5.8.7	Adjustment Units .....	77
5.8.8	Head Losses .....	77
5.8.9	Maintenance Hole Access .....	79
5.8.10	Maintenance Hole Construction Practices .....	79
5.8.11	Private Drain Connections to Maintenance Holes .....	80
5.8.12	Sampling/Inspection Maintenance Holes .....	80
5.9	<b>PRIVATE DRAIN CONNECTIONS (PDC) .....</b>	<b>80</b>
5.9.1	Materials .....	80
5.9.2	Location .....	81
5.9.3	Minimum Size and Grade .....	81
5.9.4	Connections to Sewers/Maintenance Holes .....	82
5.9.5	Vertical Clearance .....	82
5.9.6	PDC Cleanouts .....	82
5.9.7	Marking and Recording PDC Service Connections .....	82
5.10	<b>EASEMENTS .....</b>	<b>83</b>
<b>6.0</b>	<b>WASTEWATER PUMPING STATIONS .....</b>	<b>84</b>
6.1	<b>DESIGN CRITERIA .....</b>	<b>84</b>
6.1.1	General .....	84
6.1.2	Site Layout and Servicing .....	84
6.1.3	Structural .....	85
6.1.4	Flow Capacity .....	85
6.1.5	Pumps .....	86
6.1.6	Valves and Fittings .....	86
6.1.7	Flow Measurement .....	87
6.1.8	Wet Wells .....	87
6.1.9	Ventilation .....	88
6.1.10	Water Supply .....	89
6.1.11	Access .....	89
6.2	<b>EMERGENCY OPERATION .....</b>	<b>89</b>
6.2.1	Emergency Power .....	89
6.2.2	By-Pass Overflows .....	89
6.2.3	Instructions and Equipment .....	90
6.3	<b>FORCEMAINS .....</b>	<b>90</b>
6.4	<b>SAFETY .....</b>	<b>91</b>
<b>7.0</b>	<b>WATER DISTRIBUTION .....</b>	<b>92</b>
7.1	<b>GENERAL .....</b>	<b>92</b>

7.2	WATERMAIN DESIGN.....	92
7.2.1	Pressure and Flow Requirements .....	92
7.2.2	Design Water Demands .....	93
7.2.3	Friction Factors .....	93
7.2.4	Fire Demands .....	94
7.2.5	Minimum Pipe Sizes/Acceptable Pipe Sizes.....	94
7.2.6	Water Quality .....	94
7.2.7	Maximum Velocities .....	94
7.2.8	Boundary Conditions.....	95
7.3	LAYOUT OF WATERMAIN .....	95
7.3.1	Watermain Location within Road Allowance.....	95
7.3.2	Watermain Pipe Depth .....	95
7.3.3	Pipe Insulation .....	95
7.3.4	Pipe Offsets/Bends/Deflection.....	95
7.3.5	Termination of Watermains .....	96
7.3.6	Blow-Offs / Automatic Flushing Devices / Addressing Water Quality.....	96
7.3.7	Thrust Restraints.....	96
7.3.8	Watermain and Other Utilities Separation.....	97
7.3.9	Looping of Watermain/Supply Redundancy.....	99
7.4	MATERIAL .....	99
7.4.1	Reference Specifications.....	99
7.4.2	Transitions in Pipe Materials – Watermains.....	100
7.4.3	Watermains.....	100
7.4.4	Valves .....	101
7.4.5	Hydrants .....	101
7.4.6	Services .....	102
7.4.7	Tracer Wire .....	103
7.4.8	Sampling Station & Auto-Flusher .....	103
7.5	LOCATION AND SPACING VALVES .....	103
7.5.1	Location and Spacing of Watermain Valves .....	103
7.5.2	Valve Locations – Phasing of Subdivision Developments.....	104
7.6	FIRE HYDRANTS AND FIRE DEPARTMENT CONNECTIONS.....	104
7.6.1	Location/Spacing of Hydrants on Public Streets.....	105
7.6.2	Hydrants on Dead-end Streets.....	105
7.6.3	Addition of Relocation of Hydrants .....	105
7.6.4	Protection of Hydrants.....	105
7.7	WATER SERVICES, FIRE SERVICES AND PRIVATE WATERMAINS .....	106
7.7.1	Looped Water Servicing Required.....	106
7.7.2	Layout of Water Services .....	107
7.7.3	Water Service Valves.....	107
7.7.4	Water Service Entrances.....	108
7.7.5	Protection from Contamination.....	108
7.7.6	Electrical Grounding.....	108
7.8	CORROSION PROTECTION .....	108
7.9	EASEMENTS .....	109
7.10	INSTRUMENTATION .....	109

7.11	WATER METERS.....	109
7.11.1	General Requirements .....	109
7.11.2	Supply of Water Meters and Water Meter Remote Read Registers and Meter Strainers for Services 150 mm and Larger .....	109
7.11.3	Location of Water Meter .....	109
7.11.4	Installation of Water Meters.....	110
7.11.5	Meter Sizing .....	110
7.12	HYDRAULIC MODELLING.....	111
7.12.1	General .....	111
7.12.2	Design Criteria .....	112
7.12.3	Submission Requirements .....	112
7.12.4	Review by the Municipality .....	113
7.13	COMMISSIONING.....	113
7.13.1	Hydrostatic Testing .....	113
7.13.2	Swabbing and Flushing .....	114
7.13.3	Management and Disposal of Excess Material.....	114
<b>8.0</b>	<b>EASEMENTS .....</b>	<b>115</b>
<b>9.0</b>	<b>ROADWAYS .....</b>	<b>117</b>
9.1	GENERAL .....	117
9.2	ROADS DESIGN.....	117
9.2.1	Design Speed .....	117
9.2.2	Road Classifications.....	117
9.2.3	Centreline Radii.....	117
9.2.4	Radii for Curb and Gutter .....	118
9.2.5	Local Residential Street – Urban Cross Section .....	118
9.2.6	Local Residential Street – Rural Cross Section .....	118
9.2.7	Industrial Cross Section .....	118
9.2.8	Multi-Lane Roadways and Channelized Intersections .....	118
9.2.9	Right of Way and Pavement Widths .....	119
9.2.10	Maximum and Minimum Road Grades .....	119
9.2.11	Vertical Curves.....	120
9.2.12	Drainage Issues .....	120
9.2.13	Reserve Blocks .....	121
9.2.14	Rural Asphalt Lift Edge Taper .....	122
9.2.15	Pavement Structure .....	122
9.2.16	Cul-de-Sacs .....	124
9.2.17	Turning Lane Requirements.....	124
9.2.18	Minimum Frontages .....	124
9.2.19	Intersections.....	124
9.3	PARKING .....	125
9.3.1	Parking Design.....	125
9.3.2	Grading .....	125
9.4	DRIVEWAYS.....	125
9.5	SIDEWALKS, BICYCLE LANES AND PEDESTRIAN WALKWAYS .....	126

9.5.1	Sidewalks.....	126
9.5.2	Bicycle Lanes.....	126
9.5.3	Pedestrian Walkways.....	127
9.5.4	Curb and Gutter.....	127
9.6	<b>CATCH BASINS (ROAD WORKS).....</b>	<b>128</b>
9.6.1	Frames and Grates.....	128
9.6.2	Sub-Drains.....	129
9.7	<b>PAVEMENT MARKINGS.....</b>	<b>129</b>
9.7.1	Pavement Reinforcement.....	129
9.7.2	Access configuration.....	129
9.7.3	Roadside Protection.....	130
9.7.4	Regulatory/Road signs.....	130
9.8	<b>TRAFFIC CALMING.....</b>	<b>130</b>
9.8.1	Application and Methodology.....	130
9.8.2	Signage.....	130
9.8.3	Speed Cushions.....	130
9.8.4	Raised Crosswalk Design.....	130
9.8.5	Rights In/Rights Out Raised Concrete Median.....	131
9.8.6	Roundabouts.....	131
9.9	<b>STREET LIGHTING.....</b>	<b>131</b>
9.9.1	Warrants.....	131
9.9.2	Materials.....	131
9.9.3	Streetlight Design.....	132
9.9.4	Roundabout Lighting.....	133
9.9.5	Walkway Lighting Design.....	134
9.9.6	Residential Street Light Installation & Inspection Guidelines.....	134
9.10	<b>UTILITIES.....</b>	<b>134</b>
9.10.1	Telecommunications.....	134
9.10.2	Hydro.....	134
9.10.3	Gas.....	134
9.11	<b>ROADWAY SURFACE MAINTENANCE AND REHABILITATION.....</b>	<b>135</b>
<b>10.0</b>	<b>TREE PLANTING.....</b>	<b>136</b>
10.1	PLANT SUBMISSION REQUIREMENTS.....	136
10.2	STREET TREE PLANTING DESIGN OBJECTIVES.....	136
10.2.1	Street Tree Spacing and Location Requirements.....	137
10.2.2	Lot Width Considerations.....	138
10.2.3	Site Requirements.....	138
10.3	PLANTING STANDARDS AND SPECIFICATIONS.....	139
10.4	GUARANTEE AND REPLACEMENT.....	140
<b>11.0</b>	<b>GRADING.....</b>	<b>141</b>
11.1	GENERAL.....	141
11.2	GRADING REQUIREMENTS FOR VARIOUS SITUATIONS.....	141
11.2.1	Subdivisions.....	141
11.2.2	Site Plans.....	141

11.2.3	Severances, Lifting of Part Lot Control & Infill Lots.....	142
11.2.4	Blocks .....	142
11.2.5	Capital Projects.....	142
11.2.6	Parks and Open Space .....	142
11.2.7	Variations / Modifications .....	142
11.3	MAJOR/MINOR STORM DESIGN.....	143
11.4	GRADING REQUIREMENTS ALONG PROPOSED/EXISTING ROADS.....	143
11.5	GRADING STANDARDS.....	143
11.5.1	Drainage .....	144
11.5.2	Elevations .....	144
11.5.3	Slopes.....	145
11.5.4	Swales .....	145
11.5.5	Catch Basins.....	146
11.6	ADDITIONAL INFORMATION TO BE SHOWN ON PLAN.....	146
11.7	GRADING NOTES .....	147
<b>12.0</b>	<b>EROSION AND SEDIMENT CONTROL .....</b>	<b>148</b>
12.1	GENERAL .....	148
12.2	REFERENCE .....	148
12.3	GENERAL INFORMATION REQUIREMENTS .....	148
12.4	CONSERVATION AUTHORITIES .....	148
12.5	PARKS AND OPEN SPACES .....	148
12.6	TYPICAL APPLICATIONS.....	148
12.7	SPECIFICATIONS.....	149
12.7.1	Rip Rap.....	149
12.7.2	Rock Protection.....	149
12.8	SEDIMENT CONTROL MEASURE NOTES .....	150
12.9	HYDRAULIC SEEDING.....	151
<b>13.0</b>	<b>TRENCHLESS TECHNOLOGIES.....</b>	<b>153</b>
13.1	APPLICATION.....	153
13.2	GEOTECHNICAL BASELINE REPORT (GBR).....	153
13.3	TRENCHLESS DESIGN REQUIREMENTS .....	153
13.3.1	Information to be included in Construction/Tender Drawings.....	154
13.3.2	Items to be considered in the Contract Tender Documents .....	154
13.3.3	Record Drawing .....	155
<b>14.0</b>	<b>TRAILS AND CONNECTIVITY .....</b>	<b>156</b>
14.1	MULTI-USE TRAILS.....	156
14.1.1	Design & Connectivity .....	156
	<b>STANDARD DRAWINGS .....</b>	<b>157</b>

## 1.0 INTRODUCTION

### 1.1 THAMES CENTRE

The Municipality of Thames Centre is situated in southwestern Ontario at the southeastern boundary of the County of Middlesex. It is bordered on its exterior perimeters by the Townships of Perth South to the north, the Townships of Zorra and South-West Oxford to the east, the Township of Malahide and the Municipality of Central Elgin to the south, and the City of London and Municipality of Middlesex Centre to the west.

### 1.2 PURPOSE OF DESIGN CRITERIA

To streamline the development process, the Corporation of the Municipality of Thames Centre has consolidated its development requirements in this manual. This document will be periodically updated to include revisions where required. Users shall confirm with the Municipality that this is the most up-to-date version prior to making use of the contents. Throughout the remainder of this document, the Corporation of the Municipality of Thames Centre will be referred to as the Municipality.

These engineering standards reference the Ontario Provincial Standard Drawings (OPSD) and Specifications (OPSS). Unless noted otherwise in the revision Section of this manual, the latest edition of these documents applies. Provincial or Federal requirements shall supersede the requirements of this manual. As well, it is not intended to conflict with the requirements of other agencies including, but not limited to the applicable Conservation Authority, the Ministry of the Environment, Conservation and Parks, Conservation and Parks, Municipality of Thames Centre, and the Ministry of Transportation.

**NOTE:** Additional Items may be required to address specifics for any given development. Each property is looked at its own merit and may require items over and above the zoning By-Law and design guidelines requirements depending upon the site and the nature of the development. Moreover, where it is deemed appropriate or necessary the Drainage Act legislation and procedures therein shall be utilized to service the development.

The Municipality of Thames Centre maintains its right to accept or refuse any design submissions and requires an acceptable design for any given circumstances.

If any conflicts are found in this design manual report them to the Thames Centre Public Works Department.

### 1.3 LIST OF CONTACTS

See the Municipality's website at <https://www.thamescentre.on.ca/municipal-office/contact-us> for a complete listing of the Municipality's various departments and their associated contact information. Please contact the Customer Service at (519) 268-7334, extension '0', for any inquiries.

## **1.4 ENGINEER'S ROLE**

All Developers shall retain a Consulting Engineer who shall design all services and provide fulltime, on-site inspection during the installation of the services. The Consulting Engineer shall be so designated by the Association of Professional Engineers of Ontario and have a minimum of five years of land development experience. All reports, drawings and specifications shall be signed, sealed, and dated by a Professional Engineer licensed in the Province of Ontario and employed by the Consulting Engineering firm or personally designated as a Consulting Engineer.

## **1.5 BARRIER FREE CONSIDERATIONS**

All design projects throughout the Municipality must give due consideration to the Accessibility for Ontarians with Disabilities Act and must incorporate ways to remove barriers for the public.

## 2.0 GENERAL REQUIREMENTS

### 2.1 SUPPORTING STUDIES AND REPORTS

The following studies and reports may be required to support the design submissions **consistent with the direction provided by the Municipality's Official Plan**. It shall be noted that the information provided is the minimum requirement and the studies and reports may need to include further details depending upon site specific conditions. All supporting studies shall be prepared by qualified professionals to the satisfaction of the Municipality, and where appropriate, in consultation with relevant public agencies and affected parties.

The following list is not intended to be all encompassing. Additional reports or studies may be required at the discretion of the Municipality. A pre-consultation meeting shall be scheduled with the Municipality to review the required studies and, potentially, the terms of reference of those studies. A list of all reports or studies required to be submitted may include but is not limited to:

- Geotechnical Report
- Hydrogeological Assessment
- Stormwater Management Report
- Noise and Vibration Study
- Environmental Site Assessment (ESA)
- Archaeological Assessment and Report
- Topographic Survey
- Functional Servicing Report
- Cultural Heritage Impact Analysis
- Built Heritage Impacts
- Land Use Compatibility
- Environmental Impact Study (E.I.S.)
- Traffic Analysis and Impact Study
- Tree Survey and Preservation Plan
- Natural Heritage Assessment
- Natural Hazards
- Odours, Dust and Nuisance Impacts
- Record of Site Conditions (RSC)
- Planning Justification
- Accessibility for Ontarians with Disabilities Act

## **2.2 APPROVAL AGENCIES**

Depending on the location and nature of the development, the developer may be required to obtain approvals from various other regulatory agencies including (but not limited to) one or more of the following and in addition to and/or prior to obtaining approval from the Municipality:

- The Department of Fisheries and Oceans (DFO)
- The Ministry of Environment, Conservation and Parks (MECP)
- The Ministry of Natural Resources and Forestry (MNRF)
- The Ministry of Transportation (MTO)
- The Ministry of Municipal Affairs and Housing (MMAH)
- Ministry of Heritage, Sport, Tourism and Culture Industries (MHSTC)
- Thames Centre Planning and Development Services
- Thames Centre Public Works
- Thames Centre Fire Department
- Applicable Conservation Authority
- County of Middlesex

It is the responsibility of the developer to identify any required approvals from external regulatory approval agencies and to provide the Municipality with suitable written documentation of the approval from those regulatory agencies. The development will be subject to the requirements of all by-laws within the Municipality. The developer shall be required to enter into a development agreement (i.e., Subdivision Agreement, Condominium Agreement or Site Plan Agreement) with the Municipality depending on the nature of the proposal and pay any applicable planning application fees.

### **2.2.1 Subdivision Approval**

Submissions for draft plan approval, including reports and engineering drawings that are prepared by the developer's consulting engineer, are administered by Thames Centre Planning and Development Services Department. Unless noted otherwise, draft plan approval or draft approval shall have the same meaning for a plan of subdivision or plan of condominium, in all circumstances, these Engineering Design Standards shall be followed. This section describes the content of which the submissions to the Municipality shall contain. Incomplete submissions which do not attempt to address all aspects of the draft conditions or engineering criteria may be returned with a request for complete documentation unless acceptable arrangements have first been made with the Municipality.

### 2.2.1.1 Design Submissions

Design submissions are to be accompanied by any supporting documentation required for the completeness of the design of the subdivision development. Such documentation may include, but may not be limited to copies of the following reports:

- Geotechnical (soils) Report
- Traffic Impact Assessment Report
- Environmental Assessment
- Copies of reports submitted to the Conservation Authority and any other regulatory agency
- Storm Water Management Report
- Noise Report
- Functional Servicing Report
- Vibration Report
- Archeological Report

### 2.2.1.2 Drawing Standards

Refer to Section 2.3 Drafting Requirements for more details.

### 2.2.1.3 Functional Servicing Report

A functional servicing report (feasibility study) is required as background information for Draft Approval for a Plan of Subdivision. A functional report may also be required, for other mid to large-scale developments potentially having an impact on servicing, grading and drainage, water quality or quantity, and traffic, at the discretion of the Director of Planning and Development Services.

Prior to the commencement of the design and the functional report, the Developer's Engineer shall meet with the Director of Planning and Development Services or designate to discuss the Municipality's requirements. It is suggested that, when possible, this be a joint pre-consultation meeting with other affected departments and agencies.

The functional report shall provide all details, calculations, costs, alternatives, and recommendations necessary to facilitate logical and appropriate decision-making. The report shall provide all relevant background information with respect to Site Constraints / Existing Conditions such as:

- Topography and drainage

- All pipelines (Trans Canada, Union Gas etc.)
- Hydro easements / corridors
- Trunk sewers and watermains
- Utilities
- Environmental features (protected watercourses, terrestrials)
- Traffic impact studies

The functional report shall include, but will not necessarily be limited to the following considerations:

- Concept Plan
- Contour Plan
- General Plan of Services
- Drainage Plan
- Geotechnical Investigation
- Major roadway alignments, cross-sections, and intersections
- Roadway structures
- Watercourse improvement and channelization
- Railway crossings
- Parkland development
- Major trunk sewers, storm and sanitary
- Stormwater management strategy for the development, using ponds or low impact development practices
- Storm drainage systems, including overland flow routes and outlets
- Sanitary drainage systems, including capacity analysis of the receiving system
- Water distribution systems, including independent pressure and flow testing of the existing systems and network modelling
- Lot grading design
- Pumping station locations

- Electrical distribution
- Traffic Impact Study

#### **2.2.1.4 Construction Inspection**

The subdivider's consulting engineer shall conduct full time site inspection services for new subdivision developments and be available for consultation during the entire construction period.

### **2.2.2 Site Plan Approval**

To initiate the process for site plan approval, the applicant must contact the Thames Centre Planning and Development Services Department to arrange for a consultation meeting to discuss the site and submission requirements of the Municipality. Site plan submissions, including reports and site plan drawings that are prepared by the developer's consultant(s), are administered by the Thames Centre Planning and Development Services Department. This section describes the content of which the submissions to the Municipality shall contain. Incomplete submissions which do not attempt to address all aspects of the consultation or agreed upon terms of the site plan application may be returned with a request for complete documentation unless acceptable arrangements have first been made.

#### **2.2.2.1 Design Submissions**

Design submissions are to be accompanied by any supporting documentation required for the completeness of the design of the subdivision development. Such documentation may include, but may not be limited to copies of the following reports:

- Geotechnical (Soils) Report
- Traffic Impact Assessment Report
- Environmental Assessment
- Copies of reports submitted to the Conservation Authority
- Storm Water Management Report
- Noise Report
- Functional Servicing Report
- Vibration Report
- Archeological Report

#### **2.2.2.2 Drawing Standards**

Refer to Section 2.3 Drafting Requirements for more details.

## **2.3 DRAFTING REQUIREMENTS**

### **2.3.1 Drawing Standards**

The following AutoCAD Drawing Standards shall be used in new development submissions.

- The drawing scale for plan and profile drawings shall be in metric, using a scale of 1:500 horizontally and 1:50 vertically. A scale of 1:250 horizontally should be used in congested areas.
- Drawings shall be oriented such that North points up and/or to the right (or left if required).
- Dimensions and elevations shall be provided in metric units.
- Existing conditions should appear faded in comparison to the proposed work.
- The various utility lines should be identified and appear slightly darker than existing topography.
- Proposed work should appear heavier than existing conditions. Coloured drawings are strongly encouraged
- All linework and text should be drawn using a by layer colour and line type to facilitate easy modifications.

### **2.3.2 Engineering Drawings**

A complete set of Engineering Drawings, in addition to the requirements in Section 2.3.1 shall be comprised of the following:

- The approved draft plan.
- The proposed plan for registration showing all lot and block numbering and dimensioning.
- Cover Sheet
  - A cover sheet shall be provided and include the name of the development or project, the owner/developer's name, consultant's name, drawing index and a key plan showing the site location.
- General Plan of Services
  - A General Plan of Services drawing shall be prepared for all developments at a scale of no greater than 1:2000.
  - When more than one General Plan of Services drawing is required for any development then the division of drawings shall reflect the limits of the Registered Plans as closely as possible.

- The reference Geodetic Benchmark and the Site Bench Marks to be used for construction shall be identified on the General Plan of Services. Iron property bars are not acceptable construction benchmarks.
- A drawing index shall be shown on all General Plan of Services and the area covered by each drawing shall be clearly identified.
- Road allowances, lots, blocks, easements, and reserves are to be shown and are to be identified in the same manner as the Registered Plan.
- Existing services, utilities and abutting properties are to be shown, if possible.
- All proposed services to be constructed are to be shown.
- All sewers are to be shown and labeled with length, size, material, and flow directions.
- Sewer manholes and catch basins will be shown and are to be numbered in accordance with the design drawings.
- All watermains, valves, hydrants, reducers, tees, and blow-offs are to be shown.
- Watermains are to be identified by size and material.
- Dimensioning of utilities and roadways is not a requirement on the General Plan of Services.
- Registered Plan number must be shown on the As-Constructed General Plan of Services.
- All site information for parks, schools, churches, commercial and industrial development must be shown.
- If a subdivision encroaches on an existing floodplain, the approved fill lines and restrictions must be shown, as specified by the conservation authority.
- Plan and Profile Drawings
  - Scale shall be 1:500 or 1:250 horizontal; 1:50 vertical.
  - Plan and Profile drawings are required for all roadways, blocks, and easements within the development, for all outfalls beyond the development to the permanent outlet, for all boundary roadways abutting the development and for other areas where utilities are being installed below grade. Plan and profile drawings are not required for rear yard catch basin leads, but rather a cross section of the proposed work.
  - Geodetic benchmark monument location and information.
  - All existing or future services, utilities and abutting properties are to be shown.

- All proposed services to be constructed are to be shown.
- The profile portion of the drawing shall be a vertical projection of the plan portion whenever possible.
- All road allowances, lots, blocks, easements, and reserves are to be shown and are to be identified in the same manner as the Registered Plan. Lot and block frontages are to be shown.
- All curb and gutter and sidewalks shall be shown and dimensioned on the plan portion of the drawing.
- All storm and sanitary sewers and watermains shall be shown and dimensioned on the plan and shall also be plotted on the profile of the drawings. The sewers shall have a complete description on the plan and/or profile portion of the drawing including length, grade, material, class of pipe, and bedding requirements. The size of the pipe shall be plotted to full scale on the profile.
- All sewer manholes shall be shown on the plan and on the profile portions of the drawing. The manholes shall be identified number on the plan and on the profile portion of the drawing. All invert elevations shall be shown on the profile with each having reference to the north arrow.
- All catch basins and catch basin connections shall be shown. Catch basins are to be identified by number.
- All rim and invert elevations for manholes are to be shown. Catch basins shall have rim elevations only.
- All sewer manholes which have safety platforms are to be noted.
- All drop connections are to be noted and referred to the applicable O.P.S. specification, drawing or detail sheet.
- All watermains, hydrants, valves, blow-offs, etc. shall be shown, described, and dimensioned on the plan portion of the drawing. In addition, the watermain shall be plotted to true scale size on the profile portion of the drawing and labelled with the pipe size, material, and depth of cover.
- The location of all storm, water and sanitary service connections shall be shown on the plan portion of the drawing using different symbols, and line types for each service type.
- The connections to all blocks in the development shall be fully described and dimensioned (size, length, grade, invert elevations, material, class of pipe, bedding, etc.).

- The centreline of construction with 20 metre stations noted by a point or small cross shall be shown on the plan portion of the drawing.
- Area and Lot Grading Plan
- Sediment & Erosion Control Plan
- Storm Drainage Plan
- Storm Sewer Design Sheets
- Storm Water Management Report
- Sanitary Drainage Plan (including all existing servicing in the area)
- Sanitary Sewer Design Sheets
- Water Distribution Plan (including all existing servicing in the area)
- Landscaping plan
- Park Grading Plan, if necessary
- Composite Utility Plan (including Hydro Distribution System and Street Lighting)
- Street Signage and Traffic Control Plan
- All detail drawings other than the O.P.S. Detail Drawings
- All drawings pertinent to the design
- All other calculations necessary to check the design; and
- A copy of a Geotechnical Investigation report prepared by a qualified Soils Consulting Engineer

The required drawings listed above may have several drawings incorporated into one drawing as long as the drawings are neat and legible (i.e., Area/Lot grading Plan combined with Sediment and Erosion Control Plans).

Where a development has been phased, a set of as-built drawings shall be submitted at the completion of each phase. Title sheet, index pages shall be adjusted to clearly identify the location of the work. Any portion of the drawing not related to the current construction shall be indicated in a light line weight and clearly identified "NOT IN CONTRACT".

### 2.3.2.1 Site Plan Drawings

A complete set of engineering and/or architectural drawings will be required for the site plan application submission. Engineering drawings typically required for site plan developments shall include, but not be limited to:

- Site Plan Drawing (general layout with site data chart)
- Site Grading and Drainage Plan (including sediment and erosion control)
- Site Services Plan
- Landscaping Plan
- Electrical Services and Utilities Plan
- Lighting Layout and Distribution Plan
- Building Elevations Plans
- Any servicing external to the site that may be required
- In Site Plan submissions all existing infrastructure and existing structures shall be shown in greyscale and opaque. All proposed works and construction shall be solid and shown darker (or in colour) than existing to proposed works to stand out from existing.

Plan and Profile drawings will not be required for Site Plan submissions, but rather topographic plans or Site Plans are only required.

### 2.3.2.2 Drawing Sizes

Full sized drawings to be ARCH D - Full Bleed (24"x36"). Reduced drawings are to be 50% drawing scale 12" x 18".

## 2.4 CAD/GIS ASSET MANAGEMENT REQUIREMENTS

### 2.4.1 Civil 3D – AutoCAD

Computer-Aided Design (CAD) shall be used to generate all engineering drawings. Vector format "DWGS" files with no X-Refs shall be supplied. This data shall be supplied when "as-builts" are submitted for assumption. Storm sewer, sanitary sewer and watermain information must be on a separate layer.

### 2.4.2 Georeferencing

Digital files must be referenced to the Municipality's geographic reference system which is the NAD'83 (CSRS v6-2010) datum, 6 degree UTM zone 17 projection expressed in meters. The digital file must be

submitted scaled to grid (i.e., the UTM projection). All dimensions shall be shown as ground level distances.

## **2.5 AS-BUILT/RECORD DRAWING REQUIREMENTS**

### **2.5.1 Final Submission**

Prior to assumption the applicant is required to provide a complete project package to the Municipality. This package includes the following:

- Digital "As Constructed Drawing Set" in an Adobe format (.pdf file), (complete with all required signatures)
- Digital "As Constructed Drawing Set" in AutoCAD format (.dwg file, which shall include Civil 3D)
  - provide all Paper Space Title Blocks and Plot Style Tables
  - all existing survey points are to be contained in the drawing
  - all proposed TIN's, grading models and/or contour lines are to be contained in the drawing
  - all line work must be in Model Space at 1:1 scale and unrotated in a World Coordinate System (WCS)
  - drawing units are to be in metric
  - purge all old or extra drawing layers
  - bind all XRef files (no external attachments upon submission)
  - georeferenced plans are preferred, but not mandatory for submission
- All digital "Project" support files which do not reside in AutoCAD such as stormwater calculations, technical reports, etc.
- The digital formats may be from industry standard software including Microsoft Office, Adobe, Synchro Traffic, etc.

### **2.5.2 Recording of PDC Services**

Once the PDC have been placed, a record of its location must be produced for As-Constructed drawings and provided digitally to the Municipality. Water, Sanitary and Storm laterals are to be located on these drawings by showing proper plan view location which includes any bends and sweeps between the tee and the R.O.W. tie-in or stub. Also required on the drawing is the pipes invert elevation at the property line. Reach out to the Municipality for the required inspection records template.

## **2.6 DEVELOPMENT CHARGES**

To defray costs to the Municipality associated with any development or redevelopment, the Municipality may implement any or all of the provisions of the Development Charges Act, as amended. Refer to By-Law No. 17-2022.

## **2.7 COST ESTIMATE AND PROJECT SCHEDULE**

### **2.7.1 Schedules for Subdivision Agreement**

The Developer's Engineers shall prepare cost estimates for inclusion in the subdivision or land development/ redevelopment agreement. These estimates shall include all works required to construct the development to completion and assumption by the Municipality.

## **2.8 OPERATION AND MAINTENANCE REQUIREMENTS**

Where required by the Municipality, an Operations and Maintenance manual will be prepared by the Developer's Consulting Engineer. The manual shall contain all design information, regulatory standards and approvals imposed on the works as well the specifications and equipment list for the project. The manual will detail a clear process for the ongoing operations and maintenance of the facility including the necessary forms and frequency of maintenance. The information shall be to the satisfaction and approval of the Municipality.

## **3.0 STORM COLLECTION SYSTEM**

### **3.1 GENERAL**

Stormwater collection systems are typically closed conduit drainage systems below the surface of the ground that collect surface water created from rainfall or other forms of precipitation. However, stormwater systems may also consist of one or any combination of pipes, ditches, culverts, open channels, and stormwater management facilities that convey stormwater flows.

Stormwater collection systems shall be in accordance with the current Municipal Engineering Design Standards, MECP Design Criteria for ECA's, and the Municipality of Thames Centre Municipal Stormwater Management System ECA: 059-S701.

### **3.2 PERMITTED USES**

Storm sewers shall be designed to collect storm water discharge from pervious and impervious areas both on private lands and public lands via catch basins and storm private drain connections. Indirect connections of foundation drains (footing tile) via sump pumps to storm PDCs are permitted. Direct connections of foundations drains to storm sewers are not permitted. Storm drainage on private property requires a building permit before installation.

### **3.3 LOCATION AND ALIGNMENT**

Generally, stormwater pipes are to be located in front of, or are in locations accessible to each lot and block facing a municipal street and are to be located according to the typical cross-section figures in the appendix.

Stormwater pipes are to be located on the outside loop of a proposed crescent with the maintenance holes at a 1.5 m offset from the centreline of the road. Where a maintenance hole is designed to be located within the area of a roundabout, storm maintenance holes are permitted to be located within the grassed area of the roundabout, provided any proposed landscaping does not hinder the access to the maintenance hole.

#### **3.3.1 Storm Sewers on Private Property**

Stormwater collection systems on private property are regulated by the Ontario Building Code (OBC). Where there are no specific regulations in the OBC, details from this manual will apply.

### **3.4 DRAINAGE/SUBDRAINAGE AREA PLANS**

Drainage/sub-drainage area limits are to be designed in accordance with final grading and drainage limits. All areas and coefficients are to be shown for each drainage/sub-drainage areas.

## 3.5 EXTERNAL WATERSHED LIMITS AND DRAINAGE AREAS

When the design area abuts undeveloped areas, identify the external watershed limits to be included in the drainage area. All areas, coefficients and time of concentrations are to be shown for all drainage areas within external watershed limits. Storm drainage areas are to have regard for potential future development in accordance with the Municipality of Thames Centre Official Plan.

## 3.6 DESIGN CRITERIA

### 3.6.1 Design Chart

Stormwater collection system design calculations are to be completed on the standard design chart. See the Stormwater Collection Design Chart in the Appendix for details and additional information.

### 3.6.2 Sewer Peak Flows

Flows shall be calculated using the rational formula:

$$Q = 2.78 \times A \times C \times I$$

<i>Q</i>	= Peak Flow (L/s)
<i>A</i>	= Catchment Area (Ha)
<i>C</i>	= Runoff Coefficient
<i>I</i>	= Average Rainfall Intensity (mm/hr)

#### 3.6.2.1 Storm Design Curve

The criterion used in the design of stormwater design is generally to be based on the 1:2-year rainfall intensity curve provided in Figure S-1 "Rainfall Intensity - Duration Curves for Stormwater Design". Major overland flow routes are to be designed for storms greater than a 2-year storm in accordance with Section 4.4.2.

#### 3.6.2.2 Time of Concentration

The time of concentration for residential areas at the upstream end of a system shall be 19.0 minutes. For all other areas refer to Figure S-2 "Average Runoff Coefficient to Time of Concentration". Where there is a junction of two or more sewers, the time of concentration is to be adjusted when lateral flows account for 50% or more in the design flows.

The adjusted time of concentration shall be calculated using the formula:

$$T_{c-adj} = \frac{(T_{ct})(Q_t) + (T_{cl})(Q_l)}{(Q_t + Q_l)}$$

$T_{c-adj}$	= adjusted time of concentration (min.)
$T_{ct}$	= time of concentration in the trunk sewer (min.)
$Q_t$	= design flow in the trunk sewer (l/s)
$T_{cl}$	= time of concentration in the lateral sewer (min.)
$Q_l$	= design flow in the lateral sewer (l/s)

The adjusted time of concentration is used downstream of the junction maintenance hole.

### 3.6.2.3 Runoff Coefficient

Runoff coefficients are based on the amount of impervious area for a particular land use:

Land Use	Runoff Coefficient
Parks, Open Space and Playgrounds	0.2
Residential - Single Unit	0.35 – 0.50*
Residential - Semi Detached	0.50
Residential - Townhouse/Rowhouse	0.65
Residential - Apartments	0.65 – 0.70
Commercial, Institutional, and Industrial	0.70 – 0.90
Densely built, Paved	0.90
<b>Note:</b> * 0.35 to be used for rural or estate residential; standard SFR subdivisions to be 0.50.	

### 3.6.3 Sewer Capacity

Storm sewer pipe sizing is based on the design flow calculated using Manning's formula, where the pipe design flow is equal to or greater than the calculated peak flow.

$$Q = \frac{1}{n} A \times R^{2/3} \times S^{1/2}$$

$Q$	= Design Flow (L/s)
$n$	= Manning's Roughness Coefficient
$A$	= Cross-sectional Area of Flow (m <sup>2</sup> )
$R$	= Hydraulic Radius (Cross-Sectional Area of Flow (m <sup>2</sup> ) / Wetted Perimeter (m))
$S$	= Pipe Slope (m/m)

Notwithstanding the above, the minimum size storm sewer pipe permitted is 250 mm. On private property, the minimum size shall be in accordance with Part 7 of the Ontario Building Code.

#### 3.6.3.1 Manning Roughness Coefficient

A coefficient of 0.013 is to be used for all concrete and PVC pipe for pipe sizes 250 mm to 1650 mm. A coefficient of 0.011 is to be used for all pipe sizes 1800 mm or greater.

### 3.6.4 Flow Velocity

Velocity shall be calculated using the formula below assuming the pipe is flowing in a full flow scenario.

$$V = \frac{Q}{A}$$

$V$	= Flow Velocity (m/s)
$Q$	= Pipe capacity (m <sup>3</sup> /s)
$A$	= Cross-sectional Area of Pipe(m <sup>2</sup> )

The minimum velocity permitted in storm sewers to prevent scouring is 1.0 m/s. The maximum velocities permitted in storm sewers are 4.5 m/s for sewers between 300 mm to 825 mm in diameter. For storm sewers larger than 900 mm in diameter the maximum velocity is 6.0 m/s.

## 3.7 PIPE MATERIAL

Both rigid and flexible pipe are permitted in the construction of storm sewer systems including private drain connections and catch basin leads. These materials include concrete, polyvinyl chloride, and high-density polyethylene in accordance with the following:

- **PVC – Smooth Wall (CSA 182.2)**

100 mm to 600 mm as manufactured by IpeX and Royal pipe or 100 to 375 mm as manufactured by NEXT Duraloc

- **Concrete Pipe**

100 mm to 600 mm non-reinforced – CAN/CSA 257.1

Reinforced – CAN/CSA 257.2

All fittings shall be PVC fabricated and molded and shall be C.S.A. certified. On private property, materials for storm building sewers and private sewers shall comply with Part 7 of the OBC. No other materials other than those listed herein may be used. Should any supplier or contractor wish to explore alternate materials, submission for approval is to be submitted to the Municipality. The review of a submission for approval of alternate materials may require a significant amount of time on the part of the Municipality. Parties making submissions should allow for such time requirements.

The Municipality reserves the right to select any materials or product it deems appropriate for the application. It also reserves the right to remove from the specifications any product previously approved but found inappropriate for the application. This includes but is not limited to pipe material and fittings. The design engineer shall clearly indicate on drawings and contract documents the materials which are acceptable for use in a particular application where the use of one or more of the approved materials list is not acceptable.

## 3.8 PIPE DEPTH AND BEDDING MATERIAL

### 3.8.1 Minimum Depth of Cover

The minimum depth of a storm sewer shall be 1.5 m from the finished ground elevation to the obvert of the pipe. Where minimum depths cannot be achieved and therefore frost protection is warranted, insulation is required as per OPSD 1109.030

### 3.8.2 Maximum Depth of Cover

- **Concrete Pipe**

The maximum allowable cover permitted on concrete pipe is to be based on OPSD 807.01, 807.03, 807.04 and 807.05. Bedding Classes to be in accordance with OPSD 802.03, OPSD 802.031, OPSD 802.032.

Where the depth of pipe required exceeds the OPSD charts, the pipe strength requirements are to be calculated based on first principles with design variables subject to review by the Director of Public Works.

- **Flexible Pipe**

The maximum allowable cover permitted on flexible pipe is 10.5 m. The following bedding types are to be used:

Type 1 – Bedding	Up to 4.5 m
Type 2 – Bedding	Up to 10.5 m
<b>Note:</b> Bedding Classes to be in accordance with OPSD 802.03, OPSD 802.031, OPSD 802.032.	

Where trench conditions are expected to exhibit ground water in silt or fine sand, specified bedding will be defined as 19 mm crushed stone entirely surrounded by geotextile.

### 3.8.3 Crossing Clearances

There are minimum clearances required when storm sewers cross other services. In all cases this is measured from outside wall diameter to outside wall diameter.

- Crossing over or under a sanitary sewer, 230 mm clearance is required;
- Crossing over or under a watermain, 450 mm diameter or less, 0.60 m clearance between the invert of the sewer or PDC and the crown of the watermain is required;
- Crossing over or under a watermain greater than 450 mm diameter, 0.60 m clearance is required.

### 3.8.4 Minimum Distance Between Sewers

The minimum horizontal separation between parallel sewers shall be 3.0 m from center to center.

### 3.8.5 Trenchless Technologies

When trenchless installation methods are being considered for new works, please refer to Section 13 – Trenchless Technologies (for New Construction).

## 3.9 MAINTENANCE HOLES

### 3.9.1 Maintenance Hole Spacing

The maximum spacing between storm maintenance holes is dependent on the pipe size. The maximum spacing between maintenance holes for sewers from 300 mm to 975 mm diameter inclusive shall be 99 m measured horizontally or 110 m measured vertically from the top of the maintenance hole to the spring-line of the pipe, along the spring line to the next maintenance hole and vertically to the top of the maintenance hole.

Following are the maximum allowable horizontal spacing for the corresponding pipe sizes, larger for 300 dia., pipe and larger:

Length (m)	Sewer Diameter (mm)
99	300 – 975
130	1050 – 1350
160	1500 – 1650
305	≥ 1800

### 3.9.2 Precast Maintenance Hole Sizing Criteria

All sizing of storm pre-cast maintenance holes are based on incoming and outgoing pipe sizes and typical configurations shall be sized and conform to Figure S-5 “Maximum Pipe Sizes for Precast Maintenance Holes.” Minimum separation between pipes entering a manhole shall be 300 mm. For configurations outside of the typical situations, it is recommended to use manhole sizing software.

### 3.9.3 Maintenance Holes

Pre-cast maintenance holes are to be in accordance with the applicable standard OPSD 701.010 through to 701.015 and OPSD 701.03 through to 701.08. Maintenance hole tees can be constructed in lieu of regular maintenance holes on 1200 mm diameter or greater trunk sewers. See figure S-6 for details and additional design information.

Note:

- a) No deflections or lateral connections are to be constructed within the proposed maintenance hole tee.

b) Maintenance hole tees are to be located upstream to a deflection or change in sewer sizes.

### **3.9.4 Maintenance Hole Frame and Cover**

Maintenance hole frames and covers are required for all maintenance holes and shall conform with OPSD 401.01. See OPSD 401.01 for details and additional design information.

Maintenance hole frames and covers and by association steps must be aligned to avoid being located in the wheel path of the street, and to be located above a benching platform, i.e., to avoid conflict with an inletting or outletting sewer pipe, respectively. Proposed location of maintenance hole frames and covers and by association steps must be shown in plan view on the engineering drawings, represented by a solid circle reflecting the above requirements. Note, maintenance hole frame & covers are to be clear of curb & gutters on bends in the road.

### **3.9.5 Lockable Maintenance Hole Cover**

Where requested by the Municipality lockable maintenance hole covers may be required to reduce access by the public. Such locations may include areas through park blocks, open space blocks, pumping stations or treatment facilities. Where required, Lockable Maintenance Hole Covers are to be installed in accordance with OPSD 401.06.

### **3.9.6 Maintenance Hole Steps**

Maintenance hole steps are required for access and are to conform with one of the following:

- Maintenance Hole Steps – Hollow See OPSD 405.010 for details and additional design information.
- Maintenance Hole Steps – Solid See OPSD 405.020 for details and additional design information.

All steps are to be galvanized steel or aluminum.

A detail, or restoration plan is required for the relocation of maintenance hole steps within existing maintenance holes, where applicable. Maintenance hole steps shall be located to avoid conflict with an inletting or Out-letting sewer pipe. Access to maintenance holes must be above the benching platform.

### **3.9.7 Maintenance Hole Drop Structures**

Storm drop structures are required when the difference in invert elevations between the upstream and outlet sewers in the maintenance hole is equal to or greater than 0.9 m. Internal drop structures will not be permitted under any circumstances.

### **3.9.8 Maintenance Hole Safety Landings**

Maintenance hole safety landings are required at the mid-point depth of the maintenance hole, when the depth of the maintenance hole is between 5.0 m and 10.0 m. Additional safety landings are required at

third-point depths, when the maintenance hole is equal to or greater than 10.0 m to 15.0 m deep. Landings are to be in accordance with OPSD 404.020. Incoming pipes are to be below safety landings, where possible.

### 3.9.9 Benching

Benching is to conform with OPSD 701.021. Benching height shall be increased to obviate to increase hydraulic benefit as required. Where benching is different from OPSD 701.021, a benching detail is required.

### 3.9.10 Steps in Benching

Steps in maintenance hole benching are required when the pipe diameter is greater than 900 mm and benched to spring line, and when the pipe diameter is greater than 450 mm and benched to crown.

### 3.9.11 Adjustment Units

Maintenance hole adjustment units to be in accordance with OPSD 704.010. The difference in grade between the maintenance hole lid and the first ladder rung is not to exceed 600 mm. Clay brick is not to be used for adjustment units.

### 3.9.12 Head losses

When velocities in the downstream pipe from a maintenance hole exceed a velocity of 1.2 m/s, head losses must be accounted for in the design of the sewer. This may be accomplished through improvements to benching, increasing the downstream sewer diameter or in lowering the crown of the outgoing sewer.

Drops in maintenance holes to compensate for Head Loss (HL) shall be calculated using the following formula:

$$HL = K_L \frac{V^2}{2g}$$

$K_L$	= Head loss coefficient
$V$	= Downstream Velocity (m/s)
$g$	= Gravity Constant 9.81 (m <sup>2</sup> /s)

Note: Also see Figure S-4 for quick reference for head losses in maintenance holes, Head loss coefficients ( $K_L$ ) are to be applied as follows:

- i) **90 degrees:** No benching or deflector, or where they are only up to spring line. ( $K_L = 1.5$ )
- ii) **90 degrees:** Benching or deflector to crown of sewers. ( $K_L = 1.0$ )

- iii) **Less than 90 degrees:** Multiply the head loss coefficient for a 90 degree bend by a head loss ratio factor from the chart below.

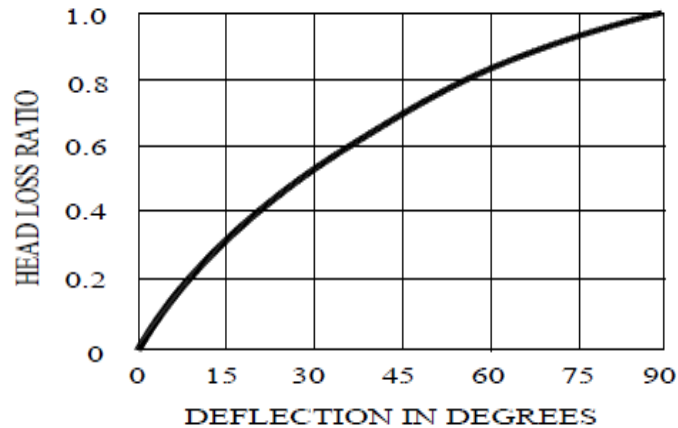

- iv) **Junctions:**

<b>Tee</b>	Outlet at right angles to inlets and no deflector between inlets.	$K_L = 1.5$
	Deflector between inlets for full height and width of incoming flows.	$K_L = 1.0$

**Side and Cross Junctions**

Value of  $K_L$  is obtained from the chart below

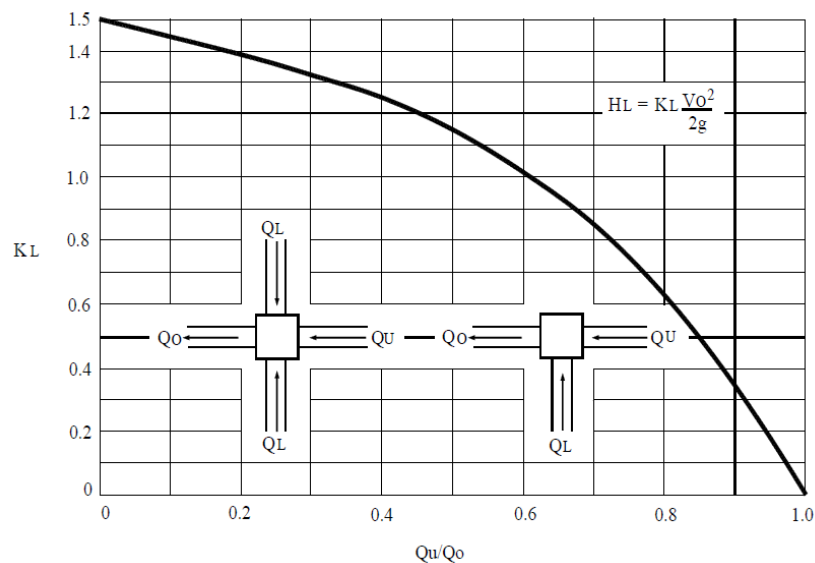

- v) **Curved Sewers:** For  $K_L$  values for calculating head losses in curved sewers (radius pipe), see Figure S-3.

### 3.9.12.1 Maintenance Hole Access

A 3.0 m to 4.6 m wide topsoil and sodded access without trees, plantings or other obstructions is required for maintenance vehicles and equipment used to access and service all storm maintenance holes with easements, open space areas, designated blocks and existing right-of-ways (i.e. boulevard). Adequate curves and turn-around facilities are required for maintenance vehicles to maneuver. Slopes (10% maximum), crossfalls (2% minimum) and drainage of access roads are also to be addressed in the design.

**Note:** A 0.3 m separation is required between the maintenance access and the top/bottom of any slopes; fences; and property line(s).

See Section 3.13 for easement requirements.

### 3.9.13 Maintenance Hole Construction Practices

- a) The void between the sewer pipe and the cored hole of the precast and pre-benched maintenance hole section shall be filled with cement bricks and approved non-shrinkable grout. Manufactured pre booted maintenance holes will be allowed.
- b) All pre-cast maintenance hole section joints shall contain an approved rubber gasket.
- c) A minimum 300 mm vertical/horizontal clearance between openings on the inside of the maintenance hole is required for all sewer and PDC connections.
- d) All maintenance hole frame and covers shall be adjusted to the finished road grade by means of metal shims at each corner or by means of an approved pre-cast adjustment ring. Metal shims are to be at least 75 mm x 200 mm (3" x 8") and their thickness is to be determined by the adjustment required. The space between the bottom of the maintenance hole frame and cover and the top of the pre-cast maintenance hole is to be at minimum the thickness of one adjustment unit and at maximum 300 mm.
- e) Where adjacent maintenance holes are located in close proximity to one another. The area between the adjacent maintenance holes shall be backfilled in accordance with the specifications in the table below:

Distance Between Adjacent Maintenance Holes	Material
≤ 0.6 m	Concrete or Crushed Stone
0.6 m – 2.4 m	Granular Material
≥ 2.4 m	Approved native material and granular material
<b>Note:</b> The above noted backfill shall be compacted to the Standard Proctor Density specified in the soils report, or as approved by the by the Director of Public Works.	

### 3.9.14 Sampling/Inspection Maintenance Holes

#### a) Requirements

Sampling/ Inspection Maintenance Holes are required where Commercial, Industrial, and sometimes Institutional developments outlet to storm sewers owned and maintained by the Municipality. The requirement for sampling/ inspection maintenance holes will be reviewed on a site-specific basis, by the Director of Public Works .

#### Location

If required, sampling/inspection Maintenance Holes shall be located on private property as close as possible to the property line, or as approved by the Director of Public Works.

#### b) Minimum Size

Sampling/Inspection Maintenance Holes shall be a minimum of 1200 mm diameter. A larger diameter Maintenance Hole may be required if noted on the Building Permit Application Drawings. Sampling/Inspection Maintenance Holes that have more than one inlet sewer shall be increased in size to ensure that there is a minimum of 0.9 m benching length downstream of all inlet sewers. Maintenance Holes shall be to OPSD standards.

## 3.10 PRIVATE DRAIN CONNECTIONS (PDCS)

### 3.10.1 Location

PDCs to single unit and semi-detached lots are to be located in accordance with Figure D-1 “Standard Servicing Locations for Single unit and Semi-Detached Lots”. PDCs to multi-unit (townhousing, rowhousing and apartments), commercial and industrial developments are to be connected to a new maintenance hole or sewer on the right-of-way. PDCs shall be installed at 90 degrees to the sewer main where possible. Under no circumstance will flow from the PDC enter the main against the flow in the main. Where horizontal or vertical bends are required, long radius sweeps shall be used. Short bends are not acceptable. If design constraints arise (i.e., top end of cul-de-sac or crescent) PDCs may have to be located in reverse location and identified as such on the servicing drawings. PDCs are required at each individual lot and a connection of two PDCs per lot shall not be permitted.

### 3.10.2 Minimum Size and Grade

The table below shows the minimum diameter and grade for a PDC allowed for the different land development designations.

Land Use	Slope (%)	Diameter (mm)
Residential, single unit and semi-detached	2	150
Residential multi-unit	1	300
Non-residential	1	375

Commercial	1	300
Institutional	1	375

### 3.10.3 Connections to Sewers/Maintenance Holes

#### a) Residential

Storm PDCs 150 mm, 200 mm and 250 mm in diameter are to be constructed to the main sewer, except in cases where a maintenance hole is located at the top end of a system (i.e., cul-de-sac). No storm PDCs are to be connected into any storm maintenance hole.

#### b) Multi-unit, Commercial and Institutional

Storm PDCs 300 mm in diameter and larger are to be connected to the main sewer at a new maintenance hole, except in cases where the main sewer is 900 mm in diameter or larger, in which case the PDC may be connected directly into the sewer.

#### c) Connections to Existing Sewers for Lot Infill Situations

Where a lot severance or lot infill condition exists and a new storm service is to be connected to an existing storm sewer, the owner of the severance/infill must contact the Director of Public Works to determine if the existing storm sewer is a combined or poorly separated sewer and/or if there is a risk of surcharging. If it is determined that there is a surcharge risk, surcharge protection is to be provided by the owner of the severed or infill lot.

When connecting PDCs to existing sewers in a lot infill situation, connections must be made utilizing an approved saddle or premanufactured tee, in accordance with OPSS 410, as amended by these standards.

Connections will not be allowed into existing maintenance holes.

### 3.10.4 Vertical Clearance

A minimum clearance of 0.6 m under/over the watermain is to be provided. For PDCs that cross over or under watermains larger than 450 mm in diameter, 0.6 m clearance is required. The designer shall refer to the Ministry of the Environment, Conservation and Parks Procedure F-6-1, Procedures to Govern the Separation of Sewers and Watermains.

### 3.10.5 PDC Detail

Typical PDC installation to the main shall be in accordance with Figure S-10 “Private Drain Connection – Less than 4.5m Depth” and Figure S-11 “Private Drain Connection – Greater than 4.5m Depth”.

### 3.10.6 PDC Cleanouts

PDC Cleanouts are not permitted. On private property, storm building sewers and private sewers shall be provided with inspection maintenance holes, in accordance with Part 7 of the OBC. Inspection maintenance holes shall be located off the right-of-way.

### 3.10.7 PDC Construction, Records and Markings

Green painted surface stakes 40 mm X 90 mm (standard 2" X 4") shall be placed after trench restoration to mark the termination of storm PDCs. These stakes shall extend from PDC invert to minimum 750 mm above finished boulevard grade. Plugged or capped service connections shall be marked on the top surface of the last 3m of the upstream end of the pipe with orange PVC adhesive tape (50 mm wide) labeled continuously in black lettering (40 mm wide) "**CAUTION STORM SEWER**". New PDCs for existing properties, to be constructed 1.2 m inside the road allowance. For PDCs to Parklands the location and design to be reviewed and approved by the Director of Public Works.

## 3.11 CATCH BASINS

Catch basins are to be provided to collect drainage from both pervious and impervious areas. The following are the general guidelines to be used in the provision of catch basins and catch basin leads.

### 3.11.1 Location

Catch basins shall be located at the low point of the curb line. Where the distance between low points is greater than 90 m additional catch basins shall be added. The desired maximum distance between catch basins or from a crest in a road to a catch basin is 90 m, measured along the curb line for each side of the road.

On street corners and intersections, the catch basin is to be located 0.6 m from the BC or EC of the curvature, and/or located on the lot line or 1.5 m from the centre of the lot to avoid conflicts with driveway and lot services respectively, wherever possible.

In the Lot/Rear Yard the catch basin and lead are to be offset 0.6 m from the property line, entirely on one lot or block. Where the catch basin and lead are entirely contained on one lot or block, easements are not required for rear yard catch basins within new subdivisions as they are to become the property and responsibility of the private property owner. Where the catch basin and lead traverse one or multiple lots or blocks to collect drainage from an adjacent lot or block, easements will be required. For parks, catch basins are to be located to minimize flow across pathways and provide positive drainage from park facilities.

### 3.11.2 Minimum Lead Diameter and Grade

Refer to the table below for the minimum diameter and grade of the catch basin lead at the locations below.

Location	Grade (%)	Diameter (mm)	Velocity (m/s)
Street	0.69	250	1
Rear Yard Lot	0.54	300	1
Parks	0.69	250	1

### 3.11.3 Types of Catch Basins

**a) Catch Basin (600 mm x 600 mm)**

Catch basins (CB) are to be constructed on all streets and some rear yards. Refer to OPSD 705.010 for details and additional design information.

**b) Twin Inlet Catch Basin (600mm x 1450mm)**

Twin inlet catch basins (TICB) are to be constructed at all low points in the curb and gutter on local, secondary collector and primary collector roads. Refer to OPSD 705.020 for details and additional design information. Driveway locations are to be identified where twin inlet catch basins are required in order to avoid conflicts.

**c) Catch Basin-Maintenance Hole**

Catch basin maintenance holes (CBMH) are to be constructed in rear yards. Refer to Figure S-9 “Precast Concrete Catch Basin Maintenance Hole” for details and additional design information.

**d) Ditch Inlet Catch Basins**

Ditch inlet catch basins (DICB) are to be constructed for ditch drainage along arterial roads, where arterial grading cannot be provided. They are also to be constructed for temporary block drainage and for outlets/inlets within a stormwater management pond. See OPSD 702.040 and OPSD 702.050 or OPSD 705.030 and OPSD 705.040 for details and additional design information.

### 3.11.4 Depth of Cover

The minimum depth of cover over a catch basin lead is to be 1.5 m within the road allowance and 1.2 m off the road allowance. Where minimum depths cannot be achieved and therefore frost protection is warranted, insulation is required in accordance with OPSD 1109.030.

### 3.11.5 Allowable Ponding

No surface ponding is allowed to develop under a 2-year design storm event. Ponding on major overland flow routes allows for 300 mm on street catch basins and 450 mm on rear year catch basins. See Grading Section 11 for further design information.

In new developments, flat see-saw profiles (identical high and low points) are not preferred for either road profile designs or rear yard swale designs. See-saw profiles shall be designed in a manner that allows

major storm flows (Overland Flows) to drain along the road or lots to an acceptable Overland Flow Outlet. Where required by the Municipality, hydraulic modelling of major overland flow routes is to be undertaken and submitted to the Municipality for review and approval.

### **3.11.6 Requirements for Length of Catch Basin Leads**

Standard catch basins (600 mm x 600 mm), maintenance hole catch basins and maintenance holes are to be constructed/connected in accordance with the following:

- Catch basins within 9.0 m of a maintenance hole are to have their leads connected into the maintenance hole.
- Catch basin leads 9.0 to 15.0 m may have their leads connected into the main sewer.
- Catch basin leads 15.0 to 30.0 m in length may be constructed by:
  - Having a catch basin at one end and the other connected into a maintenance hole or a sewer 900 mm in diameter and larger, or by
  - Having the lead connected into a sewer 825 mm in diameter or smaller at one end with a maintenance hole catch basin at the other end.
- Catch basin leads over 30.0 m in length, are to be connected into a maintenance hole or a sewer 900 mm in diameter or larger at one end and have a maintenance hole catch basin at the other end.

### **3.11.7 Catch Basin Frame and Grates**

- Catch Basin Cast Iron Frame and Flat Square Grate for standard 600 x 600 mm to be in accordance with OPSD 400.02.
- Ditch Inlet, Galvanized Steel, Honey Comb – Grating for ditch inlet catch basins to be in accordance with OPSD 403.01.

### **3.11.8 Catch Basin Steps**

- Maintenance Hole Steps – Hollow to be constructed in conjunction with a pre-cast catch basin maintenance hole in accordance with OPSD 405.010.
- Maintenance Hole Steps – Solid to be constructed in conjunction with a catch basin maintenance hole in accordance with OPSD 405.020.

### **3.11.9 Catch Basin Connections**

- Catch Basin Connection Rigid Pipe Sewer for standard 600 x 600 mm catch basin to be in accordance with OPSD 708.010.

- Catch Basin Connection Flexible Pipe Sewer for standard 600 x 600 mm catch basin to be in accordance with OPSD 708.030.

### **3.11.10 Maintenance Hole Adjustment Unit**

Maintenance hole adjustment units to be in accordance with OPSD 704.010. The difference in grade between the maintenance hole lid and the first ladder rung is not to exceed 600 mm. Clay brick is not to be used for adjustment units.

### **3.11.11 Catch Basin Lead Material**

Both rigid concrete and flexible P.V.C. pipes are permitted for the construction of catch basin leads.

### **3.11.12 Catch Basin Subdrains**

Pipe subdrains shall be provided on both sides of all catch basins installed in hard surface areas. Subdrains are not required in rear lot catch basins or in catch basins located in grassed areas.

All subdrains shall be 150 mm diameter, minimum 3.0m long, and constructed of perforated PVC pipe with manufactured filter sock and manufactured end caps. In lieu of filter sock the pipe may be wrapped in a Terrifix 270R filter cloth or equal. Perforations shall consist of 6 mm holes in four rows positioned at 4, 5, 7 and 8 o'clock and 75 mm apart longitudinally.

Pipe subdrains shall be connected to the 200 mm knockout provided in the catch basin pot, typically at subgrade elevation, shall be laid parallel with the curb, and at the same grade as finished road grade. Pipe subdrains shall be capped at the upstream end with a premanufactured end cap.

Where pipe subdrains are required for use as a French drain in lot drainage situations, pipe subdrains shall be fully bedded in 19 mm stone, which, in turn, will be completely surrounded by geotextile.

## **3.12 STORM SEWER INLET AND OUTLET STRUCTURES HEADWALLS**

Headwalls are required at the end of all storm sewer systems which provide for a transition from the storm sewer to an open channel, river, creek, SWM pond or other receiving body of storm water. In some cases, headwalls are required at the inlet of a storm sewer and/or large storm drain.

### **3.12.1 Types of Headwalls**

The following headwall designs are based on the velocity and in certain cases the diameter of the storm sewer: (taken from Municipal Works Design Manual (Municipal Engineers Association – MEA, and Ontario Provincial Standard Drawings.)

- Under 1.3 m/s with pipes diameters under 900 mm see OPSD 804.03 for details and additional design information.

- Under 2.1 m/s – MEA Type I (using OPSD 804.04 where applicable, or detail design modifying OPSD 804.04).
- 2.1 m/s to 2.7 m/s MEA Type II (using OPSD 804.04 where applicable, or detail design modifying OPSD 804.04; and 1 baffle post).
- 2.7 m/s to 4.6 m/s MEA Type III (using OPSD 804.04 where applicable, or detail design modifying OPSD 804.04; and 3 baffle posts).
- 4.6 m/s to 10.0 m/s MEA Type IV (stilling basin), or detail design.

All headwalls are to have a swale at the top of the structure to allow for surface drainage. The concrete for all headwalls is to have a minimum strength of 30 MPa with a 5% to 7% air entrainment and 70 to 90 mm slump. All exposed corners of all headwalls shall be chamfered 25 mm or more depending on the size of the headwall. Weeping tiles are to be provided on each side at the base of the sewer outlet and extended through the headwall. On larger headwalls they are placed on the side or wing walls.

### **3.12.2 Baffled Posts**

Baffle posts are to be provided for sewer flow velocities between 2.1 m/s and 4.6 m/s. The location of the posts is per the type of headwall. The height of the baffle posts shall be equal to the full depth of flow. Sizing of the posts are 1/6 the size of the pipe diameter together with reinforcing bars.

### **3.12.3 Grill/Grates**

Hot dipped galvanized grills/grates are to be placed over the storm outlets horizontally or vertically as required and shall be fixed to the headwall with anchor bolts. Grills and grates shall comply with OPSD 804.05.

### **3.12.4 Railing**

Railings are required on all headwalls which exceed 1.0 m in height from the top of the headwall to the proposed top of slope in accordance with OPSD 980.101.

### **3.12.5 Rip/Rap Rock Protection**

Rip rap is to be constructed at the end of all headwalls of all storm sewer systems and is to be placed in accordance with OPSD 810.01 and the following design criteria:

- a) on the bottom and sides up to design water levels.
- b) downstream until the projection of the side walls meet the channel side slopes at half the design water depth of flow.
- c) for headwalls at creeks and rivers, extend rip rap or gabion protection to creek or river.

Protection is to provide a smooth hydraulic flow for headwall discharge and creek or river flows.

**Note:** Rip rap design information etc. is to be in compliance with OPSS-1004. The minimum size of rip rap is 100 mm and the maximum size is 200 mm. Rock protection shall be well-graded in sizes ranging from 100 mm to 500 mm.

### **3.13 EASEMENTS**

Easements are required for all sewers (except for rear-yard catch basins) to be assumed by the municipality located outside a road allowance on privately owned property. Easements are to be of sufficient width to ensure the sewers or municipal services can be properly installed and maintained by the appropriate authority (municipality or private). An easement provides the right to use private land for a specific purpose which is in the public's interest. All maintenance holes located within easements require hard surface access. Refer to Section 8.0 of this manual for more information.

## **4.0 STORMWATER MANAGEMENT**

### **4.1 GENERAL**

Land development results in increased rates and volumes of stormwater runoff. Without stormwater management measures, the impacts of development can lead to increased flooding, degradation of water quality and aquatic ecosystems, stream erosion and property damage. Left unmanaged, stormwater often eventually leads to major public expense in infrastructure to solve flooding or erosion problems.

Prior to development being allowed to proceed, and if required by either the Upper Thames River or Kettle Creek Conservation Authority, the developer shall undertake an appropriate engineering study to determine affected drainage areas and to identify stormwater management measures as necessary to control any increases in flows to downstream receivers.

This section of the manual outlines' standards for design criteria and input parameters to provide clear and concise guidance to stormwater management practitioners and ensure a consistent approach to stormwater design within the Thames Centre region. Stormwater Management design and implementation is to be undertaken in accordance with the latest version of this manual. The design standards are not exhaustive and there may be additional design criteria that emerge through consultation with internal and external partners, or due to emerging provincial or federal legislation. The Director of Public Works is available for consultation related to site specific design criteria and encourages open discussion, particularly as it relates to complex sites.

#### **4.1.1 Background Information**

All consultants must review the applicable studies to verify if there are any watershed or area specific design criteria applicable to the site. All engineering drawings, GIS files, and topographic/LIDAR information are available to engineering consultants via a request to the Thames Centre Public Works Department.

#### **4.1.2 SWM Checklists**

Checklists have been developed to itemize the general requirements for stormwater management designs as follows:

- Table 1: Subdivision Application, Stormwater Engineering Checklist
- Table 2: Site Plan Application, Stormwater Engineering Checklist
- Table 3: Low Impact Development Design Checklist

### 4.1.3 Agency Approvals

In accordance with Section 53 of the Ontario Water Resources Act, stormwater management works are considered Sewage Works that may require an Environmental Compliance Approval (ECA). The following guidance is available from the province:

[Guide to applying for an environmental compliance approval](#)

[O. Reg 525/98: Approval Exemptions](#)

Please note that a Section 28 permit from the applicable Conservation Authority (CA) is required as part of the ECA application and is also often required for stormwater works within or in proximity to lands regulated by the CA. See Section 28 of the Conservation Authorities Act for details. When in doubt, please contact the applicable CA to confirm. Other approvals may apply. The onus is on the consulting engineer to confirm all necessary approvals.

## 4.2 SURFACE WATER CONSIDERATIONS

The purpose of this section is to communicate the Municipality's expectations related to the water quality, and quantity control targets. This section introduces a runoff control hierarchy to satisfy water quality, erosion, quantity, and water balance requirements.

### 4.2.1 Water Quality Control Objectives

One of the main purposes of stormwater management is to reduce the impact of development and urbanization on our natural watercourses. Stormwater management water quality objectives and targets are intended to protect aquatic habitat in the downstream receiver.

- Specific water quality control targets may be specified by subwatershed studies or be required to protect and enhance a sensitive feature identified through a natural heritage review of the study area.
- Typically, all discharge to the Thames River and major tributaries will be required to meet a Normal (70% TSS removal) water quality standard.

#### 4.2.1.1 Water Quality Targets

It is required that engineered stormwater management systems to satisfy water quality requirements for peak flows and volumes up to the 25 mm storm event.

A 25 mm volume capture target represents the first flush runoff event and generally 90% of storm events in Ontario. The water quality event is also identified by the province to be a 25 mm, 4 hour event in accordance with Section 4.6 of the 2003 MOE manual.

#### 4.2.1.2 Stormwater Management Control Hierarchy

When initiating a stormwater management design, consultants are recommended to first evaluate the types of SWM infrastructure systems to be designed within the following hierarchy:

- **Priority 1 (Infiltration – Retention by native soils):** infiltration to the extent possible, evapotranspiration, re-use to recharge shallow or deep groundwater, reuse collected rainwater for internal or external uses; generally applicable in highly favorable soil conditions without high groundwater. General outcomes: no discharge to the municipal storm sewer system; can partially or fully satisfy water quality and water balance requirements.
- **Priority 2 (Filtration - Volume Capture and Release):** LID filtration technologies filter runoff and typically include a subdrain connected to the storm sewer or conveyance system; generally applicable to tighter soils. General Outcomes: peak shaving/controlled discharge to the municipal conveyance system; can partially or fully satisfy water quality and water balance requirements.
- **Priority 3 (Other Volume Detention and Release):** filtration, hydrodynamic separation (i.e., end-of-pipe facilities, oil grit separators) to detain and/or treat runoff; generally applicable to tight soils, high groundwater table or contaminated sites. General outcomes: attenuated discharge to the receiving watercourse or storm sewer; these systems can satisfy water quality requirements but do not benefit the water balance
- The rationale should identify any constraints that would prohibit the implementation of Priority 1 or 2 systems including but not limited to:
  - High groundwater table (a separation of less than 1.0 m may be acceptable upon review of site conditions).
  - Site is located in a high salt loading area (i.e., expressways, urban thoroughfares, civic boulevards, bus routes, some neighbourhood collectors or receives snow storage melt) and the seasonal high groundwater elevation poses a concern.
  - Conflicts with existing utilities or infrastructure.
  - Contaminated soils.

#### 4.2.1.3 Water Quality Targets – Application

Providing Water Quality Control applies to both new and applicable redevelopment or retrofit projects as follows:

- Site Plan Applications

Water quality control shall be provided to all new and redeveloping industrial, commercial, institutional, and medium/high density residential developments where the number of new or pre-existing at-grade parking spaces is 30 or greater.

- Single Unit Residential Subdivisions

Water quality control shall be provided through municipal stormwater management systems. The consultant shall confirm if a Master Plan or Municipal Class Environmental Assessment has (1) been completed for the drainage area of the subdivision and (2) identified an associated SWM facility.

- Municipal Road Reconstruction Projects

Water quality control shall be provided for any additional impervious surface area (e.g., road widening projects). Where feasible and practical water quality controls should be retrofitted on neighbourhood streets.

#### **4.2.2 Erosion Control Objectives**

In cases where the stormwater management facility outlets to a storm sewer or ditch, a general erosion control storage of 40 m<sup>3</sup>/ha may be applied (MOE, 2003). Target is only typically applied to regional wet ponds with long extended detention drawdown for larger developments and is not to be used on smaller site development projects unless specified as a requirement by the Director of Public Works. In cases where the stormwater management facility outlets to an open watercourse, specific erosion control requirements are to be used. This information may be found within a related to Subwatershed Study or Municipal Class Environmental Assessment.

Where erosion control target information is not available, the consulting engineer shall complete a site specific fluvial geomorphological study to determine the erosion threshold velocity and associated erosion control volume.

#### **4.2.3 Minor and Major Systems**

The “Minor System” incorporates storm sewer pipes, catch basins, roadway gutters and swales, and private storm drain connections for all land uses. The stormwater minor system is designed and constructed to convey the minor flows to prevent frequent flooding in our municipal right of ways, parks, and developed parcels.

- Design standards require that storm sewers are designed to convey, at a minimum, up to the 2-year storm event using the information in this manual.

Stormwater runoff in excess of the “Minor System” capacity is referred to as the “Major System”. During higher intensity storm events, major system flow surcharges the minor system capacity, resulting in overland flows. The major system generally includes infrastructure designed to attenuate up to the 100-year peak flow and safely convey storm events up to the 250-year storm event via road allowances, easements, spillways, and channels.

- A “major system” area plan and supporting calculations must be submitted as part of the design package during the development approvals process to demonstrate safe conveyance of the

major system, identify ponding depths below the maximum as per Thames Centre Grading Standards, and provide erosion protection for events up to the 250-year event.

- A major system area plan can be incorporated with the grading plan if it includes external areas in addition to ponding limits and overland flow routes.

## 4.3 HYDROGEOLOGICAL CONSIDERATIONS

The purpose of this section is to communicate the Municipality's expectations related to the level of detail provided in hydrogeological assessments and promote consistency of the resulting technical studies.

Where required, a hydrogeological assessment is required to demonstrate:

- Responsible development and infrastructure improvements can proceed without adversely impacting the quantity or quality of existing groundwater and surface water resources, or the ecological community.
- The on-site and off-site (i.e., adjacent or downstream) groundwater quality and quantity and its users/receptors will not be adversely affected.

The level of detail to be included in the hydrogeological assessment will depend on the nature of the project, stage in the design process and general location of the site relative to downstream sensitive receivers.

It shall be noted that designs that include a subsurface infiltration component, including Low Impact Development (LID) measures or sites that have the potential to impact sensitive receivers, may require long-term groundwater monitoring (i.e., pre and post construction) to adequately establish or monitor seasonal groundwater fluctuations and/or evaluate potential impacts related to developments. This should be considered in the early stages of the planning and design process to ensure the seasonal groundwater fluctuations are captured and used to influence/confirm the proposed design.

### 4.3.1 Hydrogeological Assessment Requirements

Hydrogeological studies will vary in scope, level of detail, and methodologies depending upon project scale, project location, design constraints, design function, and the study objectives. The overall purpose of the hydrogeological assessment is to evaluate if the proposed development has the potential risk to result in negative short-term or long-term impacts to the on-site and off-site (adjacent or downstream) groundwater system(s).

Depending on the actual location of the site and its proximity to potential groundwater receptors, additional information may be required to fully assess the impacts of the development on the natural environment. **It is strongly recommended that prior to the commencement of a hydrogeological assessment study, the proponent and their consultant undertake pre-consultation with Municipality's staff to confirm the scope of the required technical study. Overall, hydrogeological assessments shall generally conform to the requirements listed in the following document:**

[“Hydrogeological Assessment Submissions”](#), Conservation Authority Guidelines to Support Development Applications, June 2013.”

As listed in the Conservation Authority Guidelines, a hydrogeological assessment shall include, at minimum:

- Evaluation of existing conditions, prior to the proposed development.
- Evaluation of potential impact of the proposed development on the natural system and assessment.
- Evaluation of monitoring and/or mitigation measures to reduce the risk of negative short-term or long-term impacts to the quality or quantity of the groundwater system.

The Municipality reserves the right to request additional investigation(s) and/or data collection above that listed above, based on criteria and site location that include, but are not limited to, the following:

- Areas of significant groundwater recharge.
- Areas either in proximity to, or within, a wellhead protection area or domestic wells.
- Areas deemed vulnerable with respect to groundwater, surface water, or nearby natural features (i.e., wetlands, woodlands).
- Areas with existing groundwater contamination issues.
- Any other conditions deemed relevant by the Municipality.

### **4.3.2 Water Balance Requirements**

A water balance analysis is required for all developments proposing changes to the site’s impervious cover or drainage conditions. Sites proposing alterations which may introduce opportunities for reasonable improvements to overall water balance conditions may also require a water balance analysis as part of the development application process or detailed design process.

The purpose of the water balance exercise is to estimate pre- and post- development infiltration and runoff conditions and identify how proposed stormwater management strategies achieve water balance objectives. The maintenance of pre-development infiltration conditions is a general requirement as groundwater frequently supports significant watershed features that are necessary components to the maintenance of a healthy watershed. The level of detail required in the water balance may vary depending on the site, proposed works, and nearby sensitive receivers.

A detailed water balance assessment would be expected to consider, at minimum, estimates of water surplus and/or deficit using the Thornthwaite and Mather approach (Thornthwaite and Mather, 1957). Depending on the complexity of the site and its proximity to nearby sensitive features, alternate

approaches can be considered, including modeling to assess short-term (event scale) and long-term (annual scale) water balance objectives.

A feature-based water balance may be required to ensure the protection of hydrological sensitive natural features such as wetlands, woodlands, or watercourses. For sites where a simple model would meet the water balance objectives (i.e., no sensitive downstream receiver, no groundwater recharge or baseflow maintenance requirements), analysis utilizing Hydrologic Cycle Component Values included in Table 3.1 of the Stormwater Management Planning and Design Manual (MOE, 2003) may be suitable. It shall be noted that the provincial Stormwater Manual (MOE, 2003) offers example estimates only and where possible, local estimates of evapotranspiration and water surplus are to be provided using the Thornthwaite and Mather approach and data obtained from a local climatic station.

Considerations for water balance analysis include:

- A single water balance assessment shall be completed as part of a development site or project to identify and mitigate impacts to surface runoff and groundwater infiltration conditions.
- Potential impacts from external drainage areas and their future land uses per the Municipality's Official Plan.

The water balance analysis may be completed as part of a Hydrogeological Assessment, a stormwater management report, or as a standalone document.

## **4.4 DESIGN REQUIREMENTS**

SWM Facility requirements are to generally conform to the design criteria in this manual, all to the satisfaction of the Municipality. This section discusses potential systems to meet current SWM criteria.

### **4.4.1 Catchment Delineation**

A catchment area is the delineation of all surface points draining toward one specific outlet that is topographically located at the lowest elevation within the area. Catchment delineation areas shall be provided for both minor (up to 2-year storm events) and major system (up to 250-year storm event). These drainage areas shall be shown and identified in the stormwater management functional report or servicing brief and engineering drawings for the project.

For projects incorporating LID solutions, catchment areas associated with the LID feature shall be provided in addition to the minor catchment areas for the storm sewer and/or catchment areas for major storm events.

Once a project design is accepted by the Director of Public Works, the final storm catchment areas are to be included in the final as-built drawing package.

#### **4.4.2 Overland Flow Routes**

Major flows must be safely conveyed via a defined Overland Flow Route (OLFR) to an appropriate outlet without causing damage to private property or municipal infrastructure, and with minimum risk to the public.

OLFRs must identify any potential barriers to the safe conveyance of stormwater. Any roadways with traffic calming measures such as raised intersections, speed bumps, or raised pedestrian crossings shall provide the following items to demonstrate that the traffic calming measure(s) will not negatively impact the OLFR conveyance and surrounding municipal and private infrastructure:

- a) R.O.W. flow conveyance calculations/details through the traffic calming measure(s)
- b) Ponding limits and associated depths for the 100 year and 250-year storm events demonstrating conformance to Grading Standards outlined in this manual
- c) Delineation of overland flow catchment area(s)
- d) Inclusion of additional inlets (i.e., Twin inlet catch basin, linear catch basin, etc.) to allow for increased inflow capacity upstream of the traffic calming measure(s) and to reduce the ponding duration on the R.O.W.
- e) Items b) and c) shall be shown on the applicable lot grading drawings or on a separate drawing for clarity

Only under extenuating circumstances will OLFRs be routed through private property and in these extenuating circumstances, a dedicated municipal easement will be required to the satisfaction of the Director of Public Works and will not be used as a precedent for other developments.

#### **4.4.3 Hydrologic Modeling**

SWMHYMO and Visual OTTHYMO are the preferred hydrologic models to be used within the Thames Centre. The Municipality also has a license for PCSWMM. Most industry standard models will be considered, and the Municipality is available for consultation if confirmation is required. For sites with drainage areas under 100 ha in rural watersheds and 50 ha in urban watersheds the Rational Method or Modified Rational Method may be appropriate.

Consultants may make use of available water resources management manuals and texts as a reference to aid in the selection of hydrologic modeling parameters. Any externally referenced material employed in parameter selection shall be properly referenced in the SWM Report and included in the document appendices.

A Professional Water Resources Engineer (Subdivider's Consulting Engineer) is responsible for recommending all SWM modeling parameters to ensure the application of adequate engineering knowledge is applied. At the same time, the Municipality is required to review the proposed SWM systems

and selection of the SWM modeling parameters/criteria to ensure compliance with the Municipality's and Provincial standards, requirements, and practices, and also ensure the adequate protection of the people and properties of Thames Centre.

Losses for the purposes of this section, refer to Initial Abstraction, infiltration, and surface depression storage. SCS Method, Horton, or Green-Ampt methods are all acceptable modeling techniques.

The City of London's recommendation of applying the Horton Method is practiced by Thames Centre.

#### 4.4.3.1 Imperviousness

For determining site runoff for Conceptual and/or Preliminary SWM plans use the values for Total Impervious Percentage (TIMP) and Directly Connected Impervious Percentage (XIMP). TIMP represents the ratio of area covered by an impervious surface (e.g. asphalt, concrete) to the entire area. XIMP represents the ratio of impervious areas directly connected to the conveyance system.

The table below lists preferred TIMP and XIMP values based on land use. These allowable ranges for TIMP and XIMP shall be applied at the conceptual/preliminary design stage to ensure sufficient land is allocated for the proposed facility. Adjustment of Impervious Percentage values at the functional/detailed design stage will be considered subject to the consulting engineer providing engineering calculations to justify the revision of these parameters.

Land Use	TIMP (%)	XIMP (%)
Residential	51 – 60	43 – 48
Medium and High Density Residential	65 – 75	45 – 55
Commercial/Industrial	75 – 90	70 – 80

- a) At the Master Plan level, TIMP and XIMP shall be assigned the MAXIMUM (not average) imperviousness allowed by Thames Centre.
- b) At the detail design level, TIMP and XIMP can be assigned the "actual" imperviousness.

#### 4.4.3.2 Initial Abstraction

Initial abstraction (Ia) represents the interception, infiltration, and surface depression storage of rainfall at the beginning of storm events. Current modeling practices recommend the Ia values summarized below:

Land Cover	Typical Values (mm)
Impervious	2
Pervious – Lawns	5
Pervious – Meadows	8
Pervious – Woods	10

Deviation from the above values may be approved at the discretion of the Director of Public Works. The onus will be on the consultant to provide sufficient rationale to support the alternate values and the Municipality retains the right to refuse alternate values.

#### **4.4.3.3 Curve Number**

The curve number (CN) is a parameter used to determine the extent of rainfall that infiltrates, rather than becoming surface runoff. CN values must be consistent with provincial guidelines and standard water resources management practices and correspond with the specific geotechnical conditions of proposed developments.

If using a HYMO based model, selection of CN shall be correlated with the applied Initial Abstraction (I<sub>a</sub>). OTTHYMO model recommends the use of CN\*. The CN\* procedures account for recalculating CN when an initial abstraction of less than 0.2\*S is used. OTTHYMO does not recommend the use of 0.2\*S as initial abstraction, requiring the use of CN\*.

The N parameter in the SWMHYMO model representing the number of linear reservoirs used for the derivation of the Nash unit hydrograph must be 3.

#### **4.4.3.4 Design Storm Selection**

In the design of site plans or subdivisions, the consulting engineer is required to evaluate the study area (i.e. total area, urban vs. rural) and recommend “critical storms” that generate the highest peak flow or the greatest volume.

The storm duration shall be selected dependent on the size of catchment and attenuation within the catchment. For smaller, urbanized catchments a shorter duration event (i.e. 3, 4, or 6 hour events) may be a reasonable duration. For larger, rural catchments a 12 or 24 hour event shall be considered. Subwatershed studies shall be reviewed for specified preferred watershed based design storms.

The most common design storms distributions include the Chicago, Atmospheric Environmental Service (AES), and SCS Type II distributions. The 3 and 6-hour Chicago event distributions are widely accepted as a synthetic distribution to be used in the design of urban areas and the 24-hour SCS event is widely accepted as a synthetic distribution to be used in rural catchments.

Rainfall intensity duration frequency (IDF) storm parameters are based on the Environment and Climate Change Canada February 2019 IDF update, with the exception of the 2-year event which remains consistent with the storm sewer design standards outlined in Figure S-1 “Rainfall Intensity - Duration Curves for Stormwater Design”. The table below includes a synthetic 25-mm event for application of the 4-hour water quality event (MOE, 2003). The UTRCA defines the Regional (i.e. regulatory) event as the 250-year event. The UTRCA’s accepted IDF curve values for the 250-year event are included below and shall be considered as part of major storm system evaluation for the protection of municipal infrastructure and public safety.

$$\text{Rainfall Intensity } \left( \frac{\text{mm}}{\text{hr}} \right) = \frac{A}{(T + B)^c} \quad \text{where } T = \text{Duration (mins)}$$

Parameter	Return Period (Years)							
	25 mm <sup>1</sup>	2 <sup>2</sup>	5	10	25	50	100	250
A	538.85	1290.00	1183.74	1574.382	2019.372	2270.665	2619.363	3048.22
B	6.331	8.500	7.641	9.025	9.824	9.984	10.5	10.03
C	0.809	0.860	0.838	0.860	0.875	0.876	0.884	0.888

Notes:

1. Synthetic 25-mm event for application of the 4-hour water quality event.
2. Approximate fit to 2 year MacLaren storm sewer design curve.

## 4.5 STORMWATER PRACTICES

This section aims to guide the planning and design of stormwater quality and quantity controls that include Low Impact Development (LID) or source control concepts as well as traditional stormwater control measures.

Each site or project will present unique options and challenges. The Municipality encourages innovation as part of any stormwater project.

### 4.5.1 Low Impact Development

To provide a short-list of LID types to be planned and designed for land-use types (i.e. Municipal Right-of-Way (ROW), Single Unit Residential, and Multi-Unit, Commercial, and Institutional Sites), Thames Centre reviewed LID measures using the following criteria:

- Effectiveness in meeting the 25 mm volume capture
- Ease of construction and integration into current construction practices
- Cost
- The Municipality's ability to conduct long-term operations and maintenance

The following identifies appropriate LID stormwater control measures based on land use type:

#### a) Municipal ROW or Easement

Third Pipe Systems: consisting of a perforated stormwater exfiltration pipe laid in a granular bedding. This system may be constructed as part of the storm sewer system (e.g. Etobicoke Exfiltration System) or as a perimeter French drain in the boulevard. Third pipe- systems are designed for both conveyance and infiltration of stormwater runoff.

**Bioretention Systems:** describes a vegetated basin that collects stormwater at the source for infiltration and filtration. Bioretention systems can be covered with landscaped plantings and mulch, or grass (naturalized or sod). Most bioretention systems will require an underdrain and an overflow catch basin connected to the storm sewer.

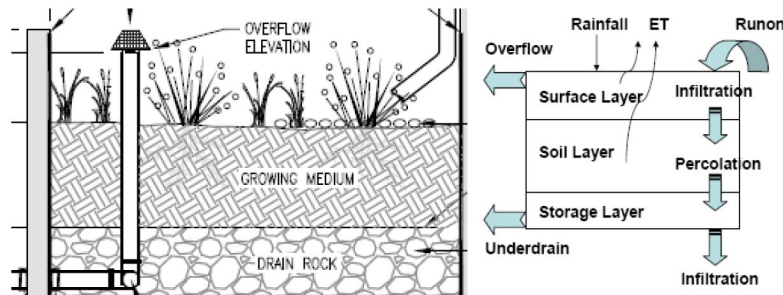

Source: Rossman, L.A. (2010). Modelling Low Impact Development Alternatives with SWMM. Journal of Water Management Modelling, 6062, 167-182. <https://www.chijournal.org/Content/Files/R236-11.pdf>

**Infiltration Swales or Dry Swales:** similar to creating a rural cross section with ditches, swales may be designed to convey stormwater runoff as part of the minor or major system. In favourable soil conditions, the infiltration swale may be able to retain stormwater runoff at-source whereas the dry swale will result in slower flow rates in comparison to a storm sewer system.

#### b) Single Unit Residential

Within single unit subdivisions, LID features are to be located within the municipal ROW or dedicated municipal easement, where they can be accessed and maintained.

#### c) Multi-unit, Commercial and Institutional Sites

Bioretention, bioswales, rain gardens, green roofs, permeable pavers, or any other LID features are encouraged for Site Plans where private landscapers and maintenance personnel will be employed on regular contracts.

Multi-unit, commercial and institutional sites are likely to provide a large number of parking spots in the form of a parking lot. Parking lots are large areas of impervious surface. It is recommended that these planters be used as small scale LID units to capture and treat a portion of the parking lot runoff through filtration and infiltration.

### 4.5.1.1 LID Screening Tool

The implementation of LIDs or source controls is highly site specific. Some systems may be more appropriate for Site Plans or parking lots rather than the municipal right-of-way. The design of each system must consider a number of factors, including but not limited to site layout, soil conditions,

elevation of the seasonal high groundwater table, and grading. It is equally important to consider lifecycle costs and ongoing operations and maintenance.

Although some sites will have constraints, the provided screening tool will assist with determining which LID options may be applied at each site:

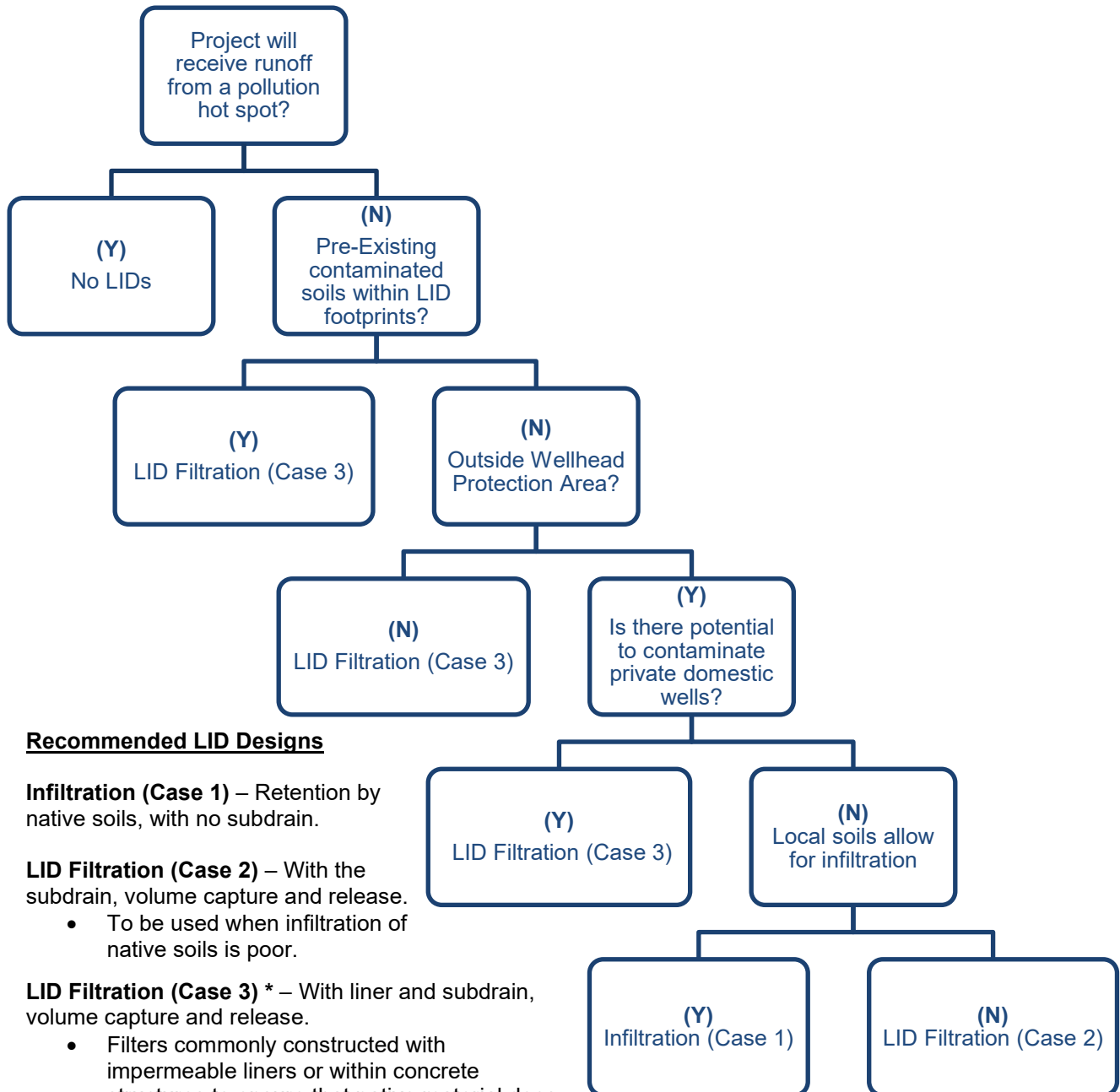

#### 4.5.1.2 Site Specific LID Design Considerations

1. **Low Permeability “Tight” Soils:** LIDs can be implemented in all soil types. “Tight soils” with low infiltration rates do not preclude the implementation of LIDs. It is expected that any water that cannot be infiltrated can be filtrated. Adaptations such as underdrains connected to downstream LID facilities or storm sewers may be required for successful implementation. In soils with an infiltration rate of less than 15 mm/hr, a subdrain will be required. Site specific infiltration testing may be required to support LID design.
2. **Risk of Groundwater Contamination:** It is important to assess if there are any potential sources of contamination (both surface and subsurface) within the LID drainage area or within surrounding soils prior to the implementation of any LID solution to evaluate the possibility for contaminating groundwater and/or mobilizing contaminant plumes. Although the majority of pollutants in stormwater runoff should be contained within filter media and underlying soils, special attention shall be made to prevent contaminants (particularly de-icing road salts) from reaching the groundwater table.
3. **Groundwater Table:** A reasonable separation distance between the bottom of the infiltration feature and the seasonal high groundwater table should be determined based on local site conditions. For smaller sites that are not in proximity to a natural heritage system, manual groundwater level information collected from monitoring wells may be adequate to assess the location of the water table. In more sensitive cases, it may be necessary to install groundwater monitoring wells equipped with continuous data loggers to capture the seasonal high groundwater elevation.
4. **Winter Operation:** It may be necessary to consider seasonal decommissioning of the LID to avoid damage from ice or winter road salt loadings, particularly if the LID outlets to a sensitive receiver.
5. **Pollution Hot Spot Runoff:** Installation of LIDs should be avoided in areas with the potential for high levels of contaminated runoff (e.g. gas stations, hazardous materials, some heavy industry).
6. **Clogging:** Stormwater directed to LIDs may contain sediment and fines that pose a risk to clogging the system. To reduce the potential for clogging, the following should be considered:
  - a. **Implement Pretreatment:** Pretreatment is essential to promote settling and capture of sediment prior to entering the infiltration system and must be included as part of a complete LID design. Options for pretreatment, include but are not limited to, deeper catch basin sumps, manufactured products (e.g. goss traps, CB shields), oil and grit separator (OGS), vegetated filter strips, or pretreatment forebays.
  - b. **Avoid Filter Fabric:** The use of filter fabric should be minimized to reduce the opportunity for an LID system to become clogged. A choking gravel layer is recommended to be used instead of filter fabric where suitable. The use of filter fabric should be limited to aspects

of the design that will not become clogged and reduce the infiltration function and capacity of the feature. The use of filter fabric may be desirable early on during construction and in final stages of site stabilization to mitigate premature clogging of filter media.

- c. **Erosion and Sediment Controls (ESCs):** Do not commission LIDs until the contributing drainage area is no longer under construction.
7. **Porosity:** A porosity of 0.35 is to be used in LID design for granular material. Other porosities may be considered where literature or field testing supports design values.
8. **Emergency Overflow:** for surface features, such as a bioretention cell, an emergency overflow to a storm sewer or ditch will be required.
9. **Vegetation:** Bioretention cells are to be planted in accordance with the neighbourhood aesthetic with paramount consideration for maintenance requirements. Naturalized plantings are encouraged and are appropriate for high volume traffic corridors. For projects within the municipal right of way or easement, the plant list must be approved by Parks Operations during the design phase. If the native soils do not possess the required nutrient levels for proper vegetation establishment, then the soil should be tilled at least 300 mm and organic material should be introduced to amend the soils.
10. **Erosion:** Limiting the slopes within an LID is important to avoid excessive erosion from occurring. If applicable, rip rap, spill aprons, check dams, and vegetation can be incorporated to help minimize erosion internally.
11. **Private Property:** If the LID is to be located on private property, the consultant shall prepare an operation and maintenance manual for the LID to ensure proper functionality. The Municipality will not accept certain LIDs on private property where no operation and maintenance plan has been presented.
12. **Standing Water and Mosquitoes:** Surface ponding of stormwater should be limited to discourage mosquitoes. Standing water should be drained in less than 24 hours. In the case of high density urban landscapes, a shorter ponding time may be more visually appealing.
13. **Setbacks from Buildings:** It is recommended to construct LIDs no closer than four (4) metres from building foundations to prevent water damage in accordance with the Zoning By-law and the Ontario Building Code. In some cases, the 4m setback requirement may be reduced, subject to installation of mitigation measures.
14. **Proximity to Underground Utilities:** Location of underground utilities needs to be determined in consultation with the City's Utility Coordination Committee to ensure proper offsets from utilities and to avoid damaging existing utilities.

15. **Overhead Wires:** Ensure future tree canopies (if applicable) will not interfere with existing overhead phone and power lines.
16. **Wellhead Protection:** Any stormwater runoff received from parking lots or roads should not be located within a two (2) year time-of-travel wellhead protection area.

#### 4.5.1.3 LID Submission Requirements

##### Design Brief

A design brief shall be prepared, as part of any LID design. The design brief may be a stand-alone document or included as part of a Functional Stormwater Management report. The design brief will form part of the ECA application for the LID system. A LID design brief shall include the following:

- Design objectives, considerations and constraints.
- Modeling methods and results.
- Design calculations.
- Field testing results including groundwater monitoring, soil analysis and in-situ infiltration testing results.
- Construction considerations.
- Operation and maintenance requirements.
- Relevant design drawings.

Any supporting documentation or relevant reports are to be included as an appendix to the design brief.

##### Design Drawings

A clear and comprehensive LID design drawing is important to communicate the uniqueness of the LID systems form and function to the contractor, site inspector and operator/owner. The drawings are a critical component to the success of the project.

Where LIDs will be incorporated within the R.O.W., the linear works and cross section drawings shall include all relevant LID features and appurtenances within the drawing sheets. A single LID details sheet shall be prepared to include:

- Limits of construction.
- Detail cross sections and/or profiles showing critical LID aspects including slopes, low points.
- Construction sequencing and protection of LID components.
- Erosion and sediment control notes and inspection requirements specific to the LID design.

- Additional construction notes to address protection and mitigate compaction of the LID feature.
- Proprietary devices.
- Landscape or planting plans.
- Soil or fill specifications and placement notes.

Examples of construction best practices that should be considered when developing a Sediment and Erosion plan for LID BMPs include:

- Installing barriers in front of curb cuts to prevent sediment from washing into facilities where curbs are part of the design.
- Excavating the final grade (invert) of the infiltration bed immediately prior to backfilling with specified aggregate and media to avoid premature facility clogging.
- Redirection of runoff including overland flow routes and roof drainage away from LID facilities during construction.
- Storing all construction materials down gradient of LID features (where possible). Construction materials stored up gradient of excavated site are to be enclosed by appropriate sediment control fencing.
- Ensuring all pipes are laid in a true line and gradient on a firm bed, free from loose material.
- Installing a sacrificial piece of filter cloth to collect dust and debris during construction. This is to be removed before biomedica is installed.

#### Operation and Maintenance Requirements of LID

The development of an Operations and Maintenance plan is a critical element for creating an effective LID feature. Refer to guidance provided in section 4.6 for the minimum requirements.

#### **4.5.2 Oil Grit Separators (OGS)**

Oil/grit separators are typically used for small drainage areas, for the following lands uses:

- i. Industrial, commercial, institutional and medium/high density residential developments (site plans)
- ii. Municipal ROW as part of development projects

The Municipality accepts technologies verified to meet water quality objectives through the Environmental Technology Verification Canada program. The OGS design methodology shall include the associated catchment area in hectares, the percentage of imperviousness used to size the OGS and the particle size distribution (PSD) used to define the % of TSS removal.

#### 4.5.2.1 OGS Design Requirement

1. **Inspection Maintenance Hole:** Every OGS shall be provided with a downstream sampling/inspection maintenance hole. This sampling maintenance hole shall be located on private property as close as possible to the property line. To the satisfaction of the Director of Public Works, the Municipality may exempt the need for an additional inspection maintenance hole in cases where:
  - a. An existing municipal maintenance hole is available close to the property line
  - b. The Municipality has permanent access to inspect the OGS unit on private property
2. **Location:** The OGS location shall allow the greatest portion of the site to be treated and access for routine inspection and repairs/maintenance.
3. **Maintenance:** OGS operation and maintenance shall be in accordance with the manufacture's operation and maintenance manual. This manual shall be included in the stormwater functional design report for the proposed development and a copy of this manual shall be provided to the owner for future and regular operation and maintenance activities.
4. **Drafting standard:** Engineering drawings for the proposed development shall delineate and indicate the size in hectares of the storm catchment area used to size the proposed OGS. Construction notes and details drawings shall include the type of OGS, the percentage of TSS removal, the associated storm catchment area in hectares, the location of the OGS and the downstream sampling maintenance hole, and a reference of to the associated OGS operation and maintenance manual.
5. **OGS special cases:** For developments proposing gas stations, an additional OGS shall be installed in the vicinity of the gas bars to capture oil spills. The additional OGS shall be sized using a reduced catchment area (the area of gas bars) and shall be provided with a separate downstream sampling/inspection maintenance hole. This additional OGS does not preclude the applicant to comply with applicable Technical Standards and Safety Authority's (TSSA) Fuels Safety Programs/regulations.

#### 4.5.3 Design of Municipal SWM Ponds

The following design guidance applies to the design of municipal SWM Facilities including, wet ponds, wetlands, and dry ponds.

Any private stormwater management facilities must comply with the standards outlined by the province (MOE, 2003).

#### 4.5.3.1 Figures

Attached, Figures D-2, D-3, and D-4, which accompany these requirements, incorporate generalized design features as published in recognized manuals or guidelines, as adapted and modified to reflect accepted practice in southern Ontario municipalities.

The figures are based on the use of Attenuation/Extended Detention and/or Wet/Hybrid Wet Facilities. However, they can also apply to dry facilities if the wet pond and sediment forebay components are removed.

#### 4.5.3.2 Water Quality Storage

Impervious percentage is described by two parameters, Total Impervious Percentage (TIMP) and Directly Connected Impervious Percentage (XIMP) values. The required storage is to be determined using the TIMP value in accordance with Table 3.2 of the Ministry of the Environment's Stormwater Management Planning and Design Manual (2003).

The water quality storage volumes per hectare are established in Table 3.2 of the MOE Manual and consist of two components: 40m<sup>3</sup>/ha of extended detention quality control storage (live storage) and the remaining portion represents permanent pool quality storage (dead storage). The required 40 m<sup>3</sup>/ha of quality extended detention storage is constant and required in all cases. The remaining permanent pool component of water quality storage is dependent upon the three following factors:

- i) Total Impervious Percentage
- ii) Protection Level of the Receiving Watercourses
- iii) Proposed type of SWM facility (i.e. wet pond, dry pond, wetland, infiltration)

Additional extended detention storage may be required for erosion/stream morphology and attenuation control to comply with the Council accepted Subwatershed Study requirements and/or to address lack of conveyance capacity in the outlet system. These parameters are to be established by the Subdivider's Consulting Engineer all to the satisfaction of the Director of Public Works.

#### 4.5.3.3 Erosion Control Storage

Erosion control storage volumes reflect the need to maintain existing fluvial geomorphology, protect watercourses from further deterioration and ensure protection of public safety and property.

All facilities require a minimum of 40 m<sup>3</sup>/ha of extended detention storage. Additional erosion control protection may be required if the facility is to be located within a subwatershed that identifies specific erosion control requirements on top of the quality control extended detention. Should the consulting engineer complete a site specific geomorphological/fluvial assessment, alteration to the erosion control requirements may be considered.

#### 4.5.3.4 SWMF Inlet Pipe Design Criteria

According to the 2003 MOE Guidelines for the Design of Storm Drainage Systems, the SWM facility inlet pipe should represent a free outlet. Therefore, the inlet pipe invert is to be above the projected 2-year storm ponding elevation. Non-compliance with this standard may create surcharge conditions within the new storm sewer system requiring additional maintenance associated with the potential sediment accumulation, as well as create potential liabilities under the Ontario Highways Act should surface ponding occur on streets.

Should, in rare cases, we need to consider deviation on the above noted design criteria, the consulting engineer will be required to undertake an engineering analysis to demonstrate that the proposed deviation will have a minimum effect on the proposed sewer Hydraulic Grade Line and will not create an adverse effect on the system.

#### 4.5.3.5 SWMF Outlet Pipe Design Criteria

SWMF outlet design to reduce operation and maintenance burden and ensure long-term functionality of the SWMF outlet. Submerged or reverse grade outlets can reduce debris accumulation at outlet structures. Submerged outlet openings shall be a minimum of 0.3 m above the pond bottom to allow for account for sediment accumulation.

Additionally, the location of any orifices within the outlet design should be considered to ensure future debris clearing can be reasonably accomplished.

#### 4.5.3.6 Specific Design Features

Fifteen key SWM Facility design features have been identified to reduce the risk of injury, while maintaining facility function. These biophysical safety features are intended to restrain access to deep standing water through a series of spatial, physical, natural and aesthetic barriers or through alternatives to direct access. The intent is to replace fencing with an appropriate alternative, while maintaining SWM function and public safety. The 15 key SWM Facility design features include:

- 1) A sediment forebay is incorporated to induce treatment and trap sediments in an isolated basin to reduce maintenance efforts during sediment cleanout works:
  - a) The Municipality encourages innovation in forebay design to reduce suspension of settled particles during high flow events.
  - b) The sediment forebay must be at least 1.0-1.5m deep to minimize potential re-suspension and ecological conditions for West Nile Virus.
  - c) The sediment forebay sizing must be done in accordance with the MOE's SWM Practices Planning and Design Manual.

- d) The sediment forebay shall be constructed with a maintenance access route to permit future monitoring and maintenance as well as provide access in the event of an emergency.
- 2) A facility depth of 1.5-2.0 m is preferred. Shallow facilities of less than 1.0 m are likely to be ineffective and should be discouraged due to the possible re-suspension of sediment and greater land requirements. The maximum SWM facility depth shall not exceed 3.0 m plus a minimum 0.3m freeboard. A positive overland flow path must be provided at the 3.3 m water level. The permanent pool depth in wet SWM facilities must be 1.0-1.5 m deep. A minimum 0.3 m freeboard must be incorporated into all SWM facility designs.
- 3) A naturalized low flow channel with a shallow channel depth (0.3 to 0.6 m preferred) leading to the area of pond draw down; SWM facility inlet sewers must be designed to enter the facility as free outlet systems during 1:2-year storm events. This standard is in accordance with the Ministry of the Environment, Conservation and Parks Guidelines for the Design of Storm Sewer Systems.
- 4) For extended detention/hybrid and wet facilities 5:1 side slopes maximum or flatter, for dry facilities 5:1 side slopes maximum must be applied around the perimeter of the sediment forebay and upper and lower cell; slopes may vary around a facility to create a natural appearance with the preferred slopes being maximums.
- 5) Steeper slopes (maximum 3:1) may be allowed to be used when these slopes are:
- representing only 15-20 % from the total perimeter at the 0.3 m above the 100 year storm event elevation.
  - combined with a minimum buffer of 5.0m from 0.3 m above the 100 year storm event elevation to the property line.
  - combined with unfriendly vegetation.
- 6) The two-year storm event extended detention and storage component of wet facilities shall discharge over a 24 to 48 hour period and the quality control facilities are not allowed to be located in line. Dry facilities should be used mostly as an attenuation/flood control system and ponding will be of relatively short duration and infrequent in occurrence; the permissible discharge for all facilities is based on detailed engineering analysis.

All maintenance holes located within stormwater management facilities require hard surface access. Access roads below the 100-year flood line will require a turfstone surface or approved alternative on a granular base. The turfstone voids shall be filled with granular A.

- 7) Stormwater from the forebay shall be held in a permanent wet retention facility and should be located in the facilities lower cell (assuming the general main cell design reflects an overall safety criteria of gentle slopes and aquatic safety benches or suitable barriers).

- 8) Any SWM facility proposed to be located within Flood Plain lands are subject to:
  - a) Conservation Authority guidelines and approvals.
  - b) Forebays being located above the 50-year storm line with any deviation from this requirement being subject to specific technical justifications approved by the Municipality.
  - c) Main facilities being located above the 25-year flood line.
- 9) A naturalized landscape plan, approved by Parks Planning and Design in consultation with the Director of Public Works, is required for all stormwater retention and detention facilities.

Seeding of exposed soil surfaces should be done as soon as possible after fine grading is complete. All landscape treatments specified in the approved plan should be installed after seed has established.
- 10) In lieu of fencing, unmowed vegetated buffers will be required around the perimeter. This buffer should be comprised of tall grasses and wild flowers, followed by trees and densely planted shrubs. A densely vegetated margin on the aquatic safety bench would serve as an aesthetic amenity and an additional natural barrier.
- 11) An aquatic safety bench must be constructed around the forebay and the main treatment cells with the lower edge to be located 0.9 m above the facility bottom with a minimum 2 m width and incorporate a minimum slope of 10:1 or flatter.
- 12) Pedestrian and cycle paths must always be located no lower than the 5-year storm event water elevation and used in conjunction with the preferred slopes discussed in item (4) to further maximize recreational user safety and minimize public risk and liability. Paths below this point and leading to the lower portions of a facility shall be posted to warn the public of potential safety hazards during facility operation.
- 13) Restricted area signage will be necessary to warn the adult public to avoid areas or activities under certain conditions if a number of these features are modified extensively and/or not included.
- 14) The minimum buffer width (separation area between the SWMF and land features such as ESA, main watercourses, significant ecological features and open space designation, etc.), is subject to Municipality's Official Plan requirements, policies, Provincial and Federal Acts, Policies and Requirements.
- 15) A Sediment and Erosion Control Plan during the construction activities must be developed and included in the Functional SWM Report for the proposed SWM Facility, to be reviewed and accepted by the Municipality. Specific requirements for the protection of adjacent natural areas may be required as outlined in the relevant Environmental Impact Statement for the development. These requirements must be applied to all SWM applications. It is recognized that in some

instances, unique circumstances may arise where some requirements cannot be accommodated. In these cases, the onus is on the proponent to demonstrate how the proposed design deviates from the requirements, yet still meets the spirit and intent of this overall document.

## **4.6 OPERATION AND MAINTENANCE**

For both public and privately owned stormwater control systems, an O&M program is required as part of the design to ensure the owner has adequate information to safeguard long-term functionality of their system. An Operation and Maintenance plan shall include but not be limited to the following information:

- Site location
- Details and locations of stormwater feature(s) on site (i.e. LID, OGS, Stormwater Facility, etc.)
- Delineation of drainage area to stormwater feature
- Understanding of system design and nuisances (i.e. filter media, underdrains, inlet and outlet control functions)
- Connections to the municipal storm sewer
- Emergency overflow location and function
- Identify significant sources of sediment accumulation and how this can be managed (e.g. street sweeping)
- Provide a list of short and long-term maintenance tasks for the LID systems with a recommended maintenance schedule (i.e. monthly or seasonal inspection or frequency for each maintenance task).
  - A short-term maintenance example would be ensuring standing water within an LID infiltrates within a 24-hour period - if not, this could be an indication of a sub-drain malfunction or clogged filter media.
  - A long-term maintenance example would be monitoring to determine pollutant saturation within the filter media and replacement/clean-outs of the filter media. Recommended Maintenance schedule.

## **4.7 DESIGN REFERENCES**

### **4.7.1 General Stormwater Design References**

1. [Stormwater Management Practices Planning and Design Manual](#) (MOE, 2003) Ministry of the Environment, 2003
2. Ministry of Transportation, Drainage and Hydrology Section, Quality and Standards Branch, 1995

3. [Low Impact Development Stormwater Management Planning and Design Guide Sustainable Technologies Evaluation Program, Living Website](#)
4. [Low Impact Development Stormwater Planning and Design Guide](#) Credit Valley Conservation and Toronto Region Conservation, 2011
5. [Hydrogeological Assessment Submissions, Conservation Authority Guidelines to Support Development Applications](#) Conservation Authorities Geoscience Group, June 2013
6. [Wetland Water Balance Monitoring Protocol](#) Toronto and Region Conservation Authority, 2016
7. [Water Management, Policies, Guidelines, Provincial Water Quality Objectives \(PWQO's\)](#) Ministry of Environment, Conservation and Parks, 1994
8. [Land Development Guidelines for the Protection of Aquatic Habitats](#) Department of Fisheries and Oceans, Ministry of Environment, Lands and Parks, 1992
9. Thornthwaite, C.W.; Mather, J.R. 1957. Instructions and tables for computing potential evapotranspiration and the water balance. Publication in Climatology 10: 185-311.
10. [Environmental Planning Policy Manual for the Upper Thames River Conservation Authority](#) Upper Thames River Conservation Authority, 2017
11. [Hydrogeological Assessment Submissions, Conservation Authority Guidelines to Support Development Applications](#), June 2013.

## 4.7.2 Stormwater Engineering Checklists

### 4.7.2.1 Table 1: Stormwater Servicing Submissions for Subdivisions

Y/N	Draft Plan of Subdivision Application Items
	Confirm the submitted Final Proposal Report (FPR) is updated to respond to all comments provided by the Municipality in the Initial Proposal Report (IPR) submission.
	Confirm that the proposed land use is consistent with Schedule A of the Thames Centre Official Plan. As well as all policies and acts of applicable agencies including the DFO, MECP, UTRCA and Municipality.
	Identify/Review previously completed studies (Municipal Class EAs, subwatershed study requirements, Functional and Detailed Design Reports, Geotechnical, Hydrogeological, EIS, drawings etc.) and identify how the proposed design meets all applicable stormwater design targets. Note any deviations in the proposed approach from previous studies with a supporting rationale for the change.
	Provide geotechnical assessment with specific recommendations regarding soil conditions and how they inform the design of the proposed SWM system.
	Provide a hydrogeological assessment that demonstrates how the water balance will be maintained as part of the subdivision or SWM design and confirm compensation/mitigation measures.

	If outlet is to a natural watercourse, conduct fluvial geomorphic study to identify the threshold erosion velocity. Conduct continuous simulation modelling to evaluate potential impact to the watercourse from the new development and identify mitigation measures.
	Identify and demonstrate available capacity in the receiving storm/drainage and SWM system, all in accordance with Municipality's design standards.
	Identify minor/major system catchments and dedicated major overland flow routes. Drawings to show catchment area boundaries for the minor and major systems, including all external areas.
	Review and ensure compliance with the Regulatory Floodplain, hazardous slope lines, fill regulations and new storm outlet requirements associated with the UTRCA approvals. Identify any deviation and additional mitigation measures required.
<b>Y/N</b>	<b>Engineering (Detailed Design) Submission Items</b>
	Where applicable, provide design input and calculations to consider site specific engineering/ecological challenges, including but not limited to, energy dissipation, or assessment of how stormwater may impact environmentally sensitive areas from a terrestrial or aquatic perspective.
	Confirm 100-year storm event ponding elevations, provide calculations and conveyance routes for 250-year storm event overland flow routes. Identify traffic calming measures and indicate any interference with overland flow route.
	Identify implementation triggers such as construction phasing and interim measures.
	Provide georeferenced shapefiles identifying the minor and major system subcatchments and dedicated major system overland flow route.
	Develop and finalize the Sediment Erosion Control plan.
	Confirm and finalize operational and maintenance requirements for any nonstandard proposed SWM systems.
	Confirm and finalize monitoring requirements (if applicable) for all proposed SWM systems.
	Finalize sign-off for submission to the MECP for the proposed work.

#### 4.7.2.2 Table 2: Stormwater Servicing for Site Plan Applications

<b>Y/N</b>	<b>Engineering (Detailed Design) Submission Items</b>
	Confirm that the proposed land use is consistent with the SWM quality, quantity/flood, stream morphology control, baseflow augmentation, infiltration, groundwater recharge/discharge and NHS requirements for the SWM facility and identify any deviation and additional mitigation measures required.
	Identify/Review previously completed studies (Municipal Class EAs, subwatershed study requirements, Functional and Detailed Design Reports, Geotechnical, Hydrogeological, EIS, drawings etc.) and identify how the proposed design meets all applicable stormwater design targets. Note any deviations in the proposed approach from previous studies with a supporting rationale for the change.
	Finalize minor and major catchment areas boundaries including all external areas. Identify any deviations to the area or runoff coefficient in relation to the Functional Report, drawings, etc. and confirm that the proposed site plan servicing meets all stormwater targets and requirements.

	Review and confirm available outlet capacity in the receiving storm/drainage and SWM system.
	Finalize review and design of the proposed minor/major system & Best Management Practices.
	Develop and finalize the Sediment Erosion Control plan (SEC) in accordance with the DFO, Applicable Conservation Authorities, Municipality and provincial requirements (this plan must be finalized and accepted prior to any development activity being approved on the subject lands).
	Review and ensure compliance with Flood Plain Lines, storages, hazardous slope lines, fill regulations and new storm outlet requirements associated with the appropriate Conservation Authority approvals.
	Review and ensure compliance with all applicable acts, standards, polices and requirements of the DFO, MECP, MNRF, Applicable Conservation Authority and the Municipality .

#### 4.7.2.3 Table 3: Low Impact Development Engineering Design Checklist

Y/N	Engineering (Detailed Design) Submission Items
	Confirm seasonal high groundwater levels of the site to an appropriate level of detail.
	Consult Stormwater Design Standards for municipally accepted LIDs based on the Screening Tool provided.
	Evaluate insitu percolation rates/ infiltration rates at proposed LID locations.
	Review recent design guidance documents for Low Impact Development systems, including Credit Valley Conservation Authority, Toronto and Region Conservation Authority, Sustainability Technologies, or other reputable source.
	Demonstrate how the stormwater design criteria are met through LIDs (quantity, quality or erosion) or identify the level of service that is being provided.
	Identify an overflow outlet for the proposed system (if required).
	Develop an Operations and Maintenance detailed manual for the proposed system(s).
	Provide a finalized georeference shapefiles identifying the minor system subcatchments associated with each LID system.

## **5.0 SANITARY COLLECTION SYSTEM**

### **5.1 GENERAL**

Public wastewater systems include piped collection systems that transport wastes wastewater of domestic origins for treatment at a wastewater treatment facility. Private wastewater systems include systems with a total design capacity of 10,000 litres per day or less, that is located on the same lot or parcel of land as the building or buildings it is intended to serve, and that is the only such system on the lot or parcel of land, these are is to be designed, constructed, operated and maintained in accordance with Part 8 of the Ontario Building Code. Systems with a total design capacity greater than 10,000 litres per day, that serve a building or buildings on another lot or parcel of land, or that exist on the same lot or parcel of land where another similar system exists falls under the jurisdiction of the Ministry of the Environment, Conservation and Parks. Connections from foundation, weeping tile drainage or roof drainage are not permitted to enter the sanitary sewer system. This section of the manual outlines' standards for design criteria and input parameters to provide clear and concise guidance for practitioners and ensure a consistent approach to sanitary design within the Thames Centre region. Location and Alignment.

Wastewater collection systems shall be in accordance with the current Municipal Engineering Design Standards, MECP Design Criteria for ECA's, and the Municipality of Thames Centre Municipal Sewage Collection System ECA: 059-W601.

Wastewater pipe is to be located in front of, or in locations accessible to each lot and block facing a municipal street. Wastewater is also to be located 1.5 metres from the centreline of the road. Refer to Figure R-1 "Typical Cross-Section – Urban Local Road – Cross Section".

### **5.2 DRAINAGE/SUB-DRAINAGE AREA PLANS**

Drainage/sub-drainage area limits for which sewers are to be designed for are to contain and follow the lot/block lines to the proposed maintenance holes located on the R.O.W. All areas and populations are to be shown for each drainage/sub-drainage area plans. When design abuts undeveloped or un-serviced areas, identify the external drainage areas to be designed for. All areas and populations are to be shown for all external drainage area limits.

### **5.3 DESIGN CHART**

Wastewater design calculations for approved drainage area plans are to be completed on the standard design chart. See the Sanitary Sewer Design chart in the appendix for details and additional design information.

## 5.4 PEAKING FACTOR CALCULATION

Peaking factor calculations are to be determined based on the Harmon formula:

$$M = 1 + \frac{14}{4 + P^{1/2}}$$

$M$  = Ratio of peak flow to average flow  
 $P$  = Tributary population in thousands

## 5.5 DESIGN CRITERIA

For determining the peak sanitary flows contributing to a sanitary sewer, follow design criteria below. It applies to development areas less than 200 ha. For areas greater than 200 ha design criteria is to be discussed and approved by the Director of Public Works.

### 5.5.1 Tributary areas less than 200 ha

a) Residential Commercial & Institutional

i. Zoning

Low Density = 30 units/hectare @ 3 people/unit  
Medium Density = 75 units/ hectare @ 2.4 people/unit  
High Density = 150-300 units/hectare @ 1.6 people/unit

ii. Lot Basis

Single Detached = 3 people/unit  
Semi-Detached = 6 people/unit

iii. Area Basis

Single Detached = 30 units/hectare @ 3 people/unit  
Semi-Detached = 30 units/ hectare @ 3 people/unit  
Multi-Unit = 75 units/hectare @ 2.4 people/unit

iv. Commercial = 100 people/hectare

v. Elementary

Maximum design number of students and employees, with consumption at 30 Litres/person/day. In calculating the peak flow, it is assumed that the total daily flow will occur over an 8 hour day and an equivalent population will be determined by dividing the total flow by the standard per capita flow of 230 Liters/day. If the design number is not known, the population will be assumed to be 400.

vi. Secondary School

Maximum design number of students and employees, with consumption at 30 Litres/person/day. In calculating the peak flow, it is assumed that the total daily flow will occur over an 8 hour day and an equivalent population will be determined by dividing the total flow by the standard per capita flow of 230 Liters/day. If the design number is not known, the population will be assumed to be 1500.

- vii. Church = 100 people/hectare
- viii. Per Capita Flow = 230 litres/capita/day
- ix. Uncertain Development Factor = 1.1
- x. Peaking Factor = 0.8 x Harmon
- xi. Infiltration Allowance = 8640 litres/hectare/day (0.100 l/s/ha)

- b) **Note:** Densities may be adjusted subject to review by the Director of Public Works as more information becomes available on specific areas

Industrial Design Criteria

i. Flow Allowance

- Light Industrial = 20,000 litres/hectare/day
- Heavy Industrial = 50,000 litres/hectare/day

**Note:** The unit flow rates for industrial development may be adjusted if specific information is available on a particular use however, consideration must be given to potential future redevelopment.

- i. Uncertainty Development = 1.1
- ii. Peaking Factor = 0.8 x Harmon
- iii. Infiltration Allowance = 8640 litres/hectare/day (0.100 l/s/ha)

**5.5.2 Peak Flow Calculation**

$$Q = \frac{\text{Population} \times \text{per Capita Flow} \times \text{Peaking Factor} \times \text{Uncertain}}{24 \times 60 \times 60} + \text{Infiltration Allowance}$$

- Q = Peak Flow (L/s)
- Per Capita Flow = 230 litres/hectare/day
- Peaking Factor (H) = Based on Harmon Formula (Refer to section (5.4))
- Uncertainty Development = 1.0 or 1.1 (Situation Dependent)
- Infiltration Allowance = 8640 litres/hectare/day (0.100 l/s/ha)

### 5.5.3 Manning's Roughness Coefficient

A coefficient of 0.013 is to be used for all concrete and PVC pipes.

### 5.5.4 Pipe Size

Pipe size is determined using the formula where the pipe design flow capacity is equal to or greater than the calculated peak design flow:

$$Q = \frac{1}{n} \times A \times R^{2/3} \times S^{1/2}$$

<i>Q</i>	= Design Flow Capacity (L/s)
<i>n</i>	= Manning's Roughness Coefficient
<i>A</i>	= Cross-sectional Area of Flow (m <sup>2</sup> )
<i>R</i>	= Hydraulic Radius (Cross-Sectional Area of Flow (m <sup>2</sup> ) / Wetted Perimeter (m))
<i>S</i>	= Pipe Slope (m/m)

**Note:** Notwithstanding the above, the minimum allowable size of a sanitary sewer shall be 200 mm. On private property, the minimum size for sanitary building sewer shall be 100 mm, in accordance with Part 7 of the OBC.

### 5.5.5 Flow Velocity

Velocity shall be calculated using the formula below assuming the pipe is flowing in a full flow scenario.

$$V = \frac{Q}{A}$$

<i>V</i>	= Flow Velocity (m/s)
<i>Q</i>	= Pipe capacity (m <sup>3</sup> /s)
<i>A</i>	= Cross-sectional Area of Pipe (m <sup>2</sup> )

The minimum velocity permitted in sanitary sewers is 0.6 m/s. The maximum velocities permitted in sanitary sewers is 4.5 m/s.

### 5.5.6 Minimum Grades

The minimum grade on a 200 mm diameter wastewater pipe is 0.33%. Where there are only a few dwelling units connected to the upper section of a 200 mm sanitary sewer, the minimum grades shall be adjusted as follows:

1 to 5 units .....	0.61%
6 to 8 units .....	0.52%
9 to 12 unit .....	0.43%
13 or more units .....	0.33%

**Note:** The minimum grade on all other sewer sizes shall be established by determining the minimum grade necessary to achieve a velocity of at least 0.6 m/sec.

## 5.6 PIPE MATERIAL

Both rigid and flexible pipe are permitted in the construction of wastewater pipe including private drain connections in accordance with the following:

- P.V.C. – Smooth Wall (CSA 182.2)  
100 mm to 600 mm as manufactured by IpeX and Royal pipe or 100 mm to 375 mm as manufactured by NEXT Duraloc.
- Concrete Pipe
  - non-reinforced – CAN/CSA 257.1 100 mm to 600 mm
  - reinforced – CAN/CSA 257.2

All fittings shall be PVC fabricated and molded and shall be C.S.A. certified. On private property, materials for sanitary building sewers and private sewers shall comply with Part 7 of the OBC. No other materials other than those listed herein may be used. Should any supplier or contractor wish to explore alternate materials, submission for approval is to be submitted to the Municipality. The review of a submission for approval of alternate materials may require a significant amount of time on the part of the Municipality. Parties making submissions should allow for such time requirements. The Municipality reserves the right to select any materials or product it deems appropriate for the application. It also reserves the right to remove from the specifications any product previously approved but found inappropriate for the application. This includes but is not limited to pipe material and fittings. The design engineer shall clearly indicate on drawings and contract documents the materials which are acceptable for use in a particular application where the use of one or more of the approved materials lists is not acceptable.

All precast concrete pipe joints shall be sealed with a 12-inch-wide exterior joint wrap meeting the Materials requirements of this specification and installed according to manufacturer's recommendations.

## 5.7 PIPE DEPTH AND BEDDING MATERIAL

### 5.7.1 Minimum

The minimum depth of a wastewater pipe shall be 2.4 m from the finished ground elevation to the obvert of the pipe. Where minimum depths cannot be achieved and therefore frost protection is warranted, insulation is required as per OPSD 1109.030.

### 5.7.2 Maximum Depth of Cover/Pipe Strength Design

For Maximum depth of cover, where trench conditions are expected to exhibit seeping ground water in silt or fine sand, specified bedding will be defined as 19 mm crushed stone entirely surrounded by geotextile.

- **Concrete Pipe**

The maximum allowable cover permitted on concrete pipe is to be based on OPSD 807.01, 807.03, 807.04 and 807.05. Bedding Classes to be in accordance with OPSD 802.03, OPSD 802.031, OPSD 802.032.

Where the depth of pipe required exceeds the OPSD charts, the pipe strength requirements are to be calculated based on first principles with design variables subject to review by the Director of Public Works.

- **Flexible Pipe**

The maximum allowable cover permitted on flexible pipe is 10.5 m. The following bedding types are to be used:

Type 1 – Bedding	Up to 4.5 m
Type 2 – Bedding	Up to 10.5 m
<b>Note:</b> Bedding Classes to be in accordance with OPSD 802.03, OPSD 802.031, OPSD 802.032.	

Where trench conditions are expected to exhibit ground water in silt or fine sand, specified bedding will be defined as 19 mm crushed stone entirely surrounded by geotextile.

### 5.7.3 Crossing Clearances

Minimum clearances required when wastewater pipes cross other services as measured from outside wall diameter to outside wall diameter:

- over or under a storm sewer, 250 mm clearance is required;
- over or under a watermain, 450 mm diameter or less, 0.50 m between the invert of the sewer or PDC and the crown of the watermain is required.

### 5.7.4 Minimum Distance between Wastewater Pipes

The minimum horizontal distance between service pipes shall be 3.0 m from center to center. Special cases are to be reviewed for site specific design constraints and depths.

### 5.7.5 Trenchless Technologies

When trenchless installation methods are being considered for new works, please refer to Section 13 – Trenchless Technologies (for New Construction).

## **5.8 MAINTENANCE HOLES**

### **5.8.1 Spacing of Maintenance Holes**

The maximum spacing between wastewater maintenance holes shall be 99 metres measured horizontally or 110 metres measured vertically from the top of the maintenance hole, to the spring line of the pipe, along the spring line to the next maintenance hole and vertically to the top of the maintenance hole.

When spacing of a maintenance hole dictates that the maintenance hole should be placed within the vicinity of a roundabout, sanitary maintenance holes are not permitted to be located within the grassed area of the roundabout. Sanitary maintenance holes must be located within the apron of the island, for maintenance purposes.

Maintenance holes are required where there is a change in the direction of the flow, slopes, a change in the diameter of sewers, and/or a lateral sewer connection.

#### **5.8.1.1 Precast Maintenance Hole Sizing Criteria**

All sizing of storm pre-cast maintenance holes are based on incoming and outgoing pipe sizes and typical configurations shall be sized and conform to Figure S-5 “Maximum Pipe Sizes for Precast Maintenance Holes”. Minimum separation between pipes entering a manhole shall be 300 mm. For configurations outside of the typical situations, it is recommended to use manhole sizing software.

#### **5.8.1.2 Maintenance Holes**

Precast maintenance holes are to be in accordance with the applicable standard OPSD 701.010 through to OPSD 701.015 and OPSD 701.03 through to OPSD 701.08.

#### **5.8.1.3 Maintenance Hole Tee**

Maintenance hole tees are not allowed for any wastewater collection system.

#### **5.8.1.4 Maintenance Hole Frame and Covers**

Maintenance hole frames and covers to follow OPSD 401.01. Maintenance hole frames and covers are to be clear of curb and gutters on bends in the road for new construction. May be located in the curb and gutter on reconstruction projects, only as approved. Maintenance hole frames and covers and by association steps must be aligned to avoid being located in the wheel path of the street, and to be located above a benching platform, i.e. to avoid conflict with an inletting or outletting sewer pipe, respectively. Proposed location of maintenance hole frames and covers and by association steps must be shown in plan view on the engineering drawings, represented by a solid circle reflecting the above requirements. Refer to Figure S-8 for a typical manhole frame and cover.

### **5.8.1.5 Use of Maintenance Hole Inserts required during construction**

The use of inserts in sanitary maintenance holes will be required in areas of new construction and are required to remain in place permanently.

### **5.8.1.6 Watertight Maintenance Hole**

Watertight maintenance hole lids are required when sanitary maintenance holes are located within overland storm flow routes. These locations are within flood plain areas, within gutter locations and within an easement and/or open space area where overland flow is directly over and or adjacent to the maintenance hole lids. Watertight maintenance hole lids are also required under sanitary surcharge conditions. See Figure S-7 for details and additional design information.

Watertight maintenance hole lids are not required under the following circumstances:

- a) Where design dictates that the maintenance hole lids end up in the curb and gutter and where it is possible to rotate the cone so that the maintenance hole lid is clear of the gutter, the cone should be rotated such that a water tight lid would not be required;
- b) Where, in the profile design of the street, the maintenance hole is located in the low point of an overland flow route, the maintenance hole may be in standard location, but would be submerged under a greater than two year storm event. Maintenance holes located in a standard location on streets that carry an overland flow route with a continuous grade, or cascading grade (even though some of these may be briefly submerged) do not require water tight lids.

## **5.8.2 Lockable Maintenance Hole Covers**

Lockable maintenance hole covers are required to reduce access by the public. They can be located through park blocks, open space blocks, pumping stations or pollution control plants. See OPSD 401.06 for details and additional design information.

## **5.8.3 Maintenance Hole Steps**

Maintenance hole steps are required for access and are to conform with one of the following:

- a) Maintenance Hole Steps – Hollow. See OPSD 405.010 for details and additional design information.
- b) Maintenance Hole Steps – Solid. See OPSD 405.020 for details and additional design information.
- c) All steps are to be galvanized steel or aluminum; and a detail or restoration plan is required for the relocation of maintenance hole steps within existing maintenance holes, where applicable.
- d) Maintenance hole steps shall be located to avoid conflict with an inletting or outletting sewer pipe. Access to maintenance holes must be above the benching platform.

## 5.8.4 Maintenance Hole Drop Structures

Drop structures are required when the difference in invert elevations between the upstream and outlet sewers in the maintenance hole is equal to or greater than 0.6 metres. Internal drop structures will not be permitted under any circumstances.

## 5.8.5 Maintenance Hole Safety Landings

Maintenance hole safety landings are required at the mid-point depth of the maintenance hole when the depth of the maintenance hole is between 5.0 and 10.0 metres. Additional safety landings are required at third-point depths, when the maintenance hole is equal to or greater than 10.0 to 15.0 metres deep. Incoming pipes are to be below safety landings, where possible. Landings to be in accordance with OPSD 404.020.

## 5.8.6 Benching

Benching is to conform to OPSD 701.021, if it differs a benching detail is required. Benching height should be increased to obviate to increase hydraulic benefit as required.

## 5.8.7 Adjustment Units

Maintenance hole adjustment units are required on all maintenance holes to ensure that proper grade is provided between the top of the maintenance hole and the maintenance hole lid. Maintenance hole adjustment units to follow OPSD 704.010. Ensure that the difference in grade between the maintenance hole lid and the first ladder rung does not exceed 450 mm. Clay brick is not to be used for adjustment units.

## 5.8.8 Head Losses

When velocities in the downstream pipe from a maintenance hole exceed 1.2 m/s, head losses must be accounted for in the design of the sewer. This may be accomplished through improvements to benching, increasing the downstream sewer diameter or in lowering the crown of the outgoing sewer.

Drops in maintenance holes to compensate for Head Loss (HL) shall be calculated using the following formula:

$$HL = K_L \frac{V^2}{2g}$$

$K_L$	= Head loss coefficient
$V$	= Downstream Velocity (m/s)
$g$	= Gravity Constant 9.81 (m <sup>2</sup> /s)

Refer to Figure S-4 “Head Losses in Maintenance Holes”

Head loss coefficients ( $K_L$ ) are to be applied as follows:

- i) **90 degrees:** No benching or deflector, or where they are only up to spring line. ( $K_L = 1.5$ )
- ii) **90 degrees:** Benching or deflector to crown of sewers. ( $K_L = 1.0$ )
- iii) **Less than 90 degrees:** Multiply the head loss coefficient for a 90 degree bend by a head loss ratio factor from the chart below.

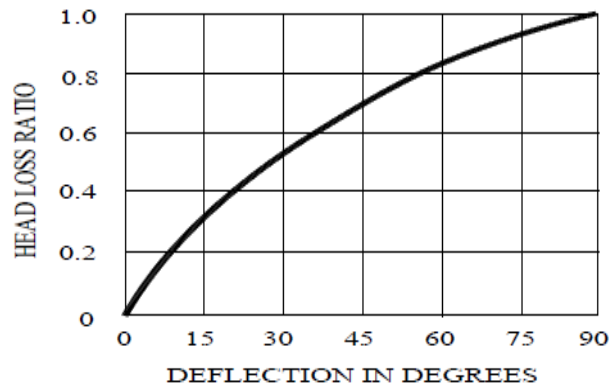

iv) **Junctions:**

- Tee**
- Outlet at right angles to inlets and no deflector between inlets.  $K_L = 1.5$
  - Deflector between inlets for full height and width of incoming flows.  $K_L = 1.0$

**Side and Cross Junctions**

Value of  $K_L$  is obtained from the chart below

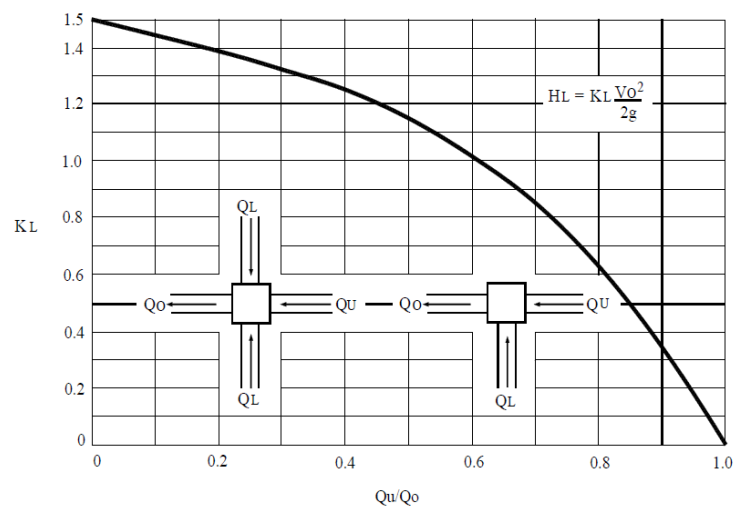

- v) **Curved Sewers:** For  $K_L$  values for calculating head losses in curved sewers (radius pipe), see Figure S-3.

### **5.8.9 Maintenance Hole Access**

A 4.0 m wide asphalt with granular base access is required for maintenance vehicles and equipment used to access and service maintenance holes within easements, open space areas, designated blocks and existing right-of-ways (i.e. boulevards). Adequate curves and turn-around facilities are required for maintenance vehicles to maneuver. Items such as slopes (4% maximum), cross-falls (2% minimum to 4.5% maximum) and drainage of access roads are to be addressed in the design. A 0.3 m separation is required between the maintenance access and the top/bottom of any slopes; fences; and property line(s).

All maintenance holes located within open space or park areas require hard surface access. Wherever possible, access roads in municipal parks and open spaces are to be integrated into the public open space pathway networks and respect natural heritage features. Where maintenance access is integrated, maintenance hole access lids are to be offset from the pathway. See Section 5.10 for easement requirements.

### **5.8.10 Maintenance Hole Construction Practices**

- a) The connection between inlet and outlet pipes and the maintenance hole shall be watertight and in accordance with OPS 407 subsection 407.07.13.
- b) All precast maintenance hole section joints shall contain an approved rubber gasket. In areas of high groundwater, exterior joint collars or external wrapping (i.e., 'Cretex' waterproofing or equivalent, installed as per manufacturer's specifications) of the maintenance hole joints will be required. This requirement may be waived if it can be demonstrated that, based on specific groundwater conditions, the standard rubber gasket is sufficient to prevent infiltration.
- c) Any used mortar or approved non-shrinkable grout shall be mixed and placed in accordance with the manufacturer's specifications.
- d) A minimum 300 mm vertical/horizontal clearance between openings on the inside of the maintenance hole is required for all sewer and PDC connections.
- e) Where surface asphalt is to be delayed more than four weeks, maintenance hole frame and covers are to be adjusted to base asphalt grade. Adjustment to finish grade is not to be completed until the placement of surface asphalt is imminent.
- f) Adjustment to the finished road grade shall be accomplished by means of metal shims at each corner or by means of an approved precast adjustment ring. Metal shims are to be at least 75 mm x 200 mm (3"x 8") and their thickness is to be determined by the adjustment required. The space between the bottom of the maintenance hole frame and cover and the top of the precast maintenance hole is to be at minimum the thickness of one adjustment unit and at maximum 300 mm.

- g) Where adjacent maintenance holes are located in close proximity to one another, the area between the adjacent maintenance holes shall be backfilled in accordance with the specifications in the following table:

Distance Between Adjacent Maintenance Holes	Material
≤ 0.6 m	Concrete or Crushed Stone
0.6 m – 2.4 m	Granular Material
≥ 2.4 m	Approved native material and granular material
<b>Note:</b> The above noted backfill shall be compacted to the Standard Proctor Density specified in the soils report, or as approved by the by the Director of Public Works.	

### 5.8.11 Private Drain Connections to Maintenance Holes

Residential sanitary private drain connections are NOT to be constructed into any sanitary maintenance holes.

### 5.8.12 Sampling/Inspection Maintenance Holes

- **Requirements**

Sampling/Inspection maintenance holes are typically required where Institutional, Commercial, and Industrial developments outlet to sanitary sewers owned and maintained by the Municipality. Sampling/inspection maintenance holes are required for all industrial and commercial sites.

- **Location**

If required, Sampling/Inspection Maintenance Holes shall be located on private property as close as possible to the property line, or as approved by the Director of Public Works.

- **Minimum Size**

Sampling/Inspection Maintenance Holes shall be a minimum of 1200 mm diameter. A larger diameter Maintenance Hole may be required if noted on the Building Permit Application Drawings. Sampling/Inspection Maintenance Holes that have more than one inlet sewer shall be increased in size to ensure that there is a minimum of 0.9m benching length downstream of all inlet sewers. Maintenance Holes shall be to OPSD standards.

## 5.9 PRIVATE DRAIN CONNECTIONS (PDC)

Typical PDC connection to the main shall be in accordance with Figure S-10 “Private Drain Connection (Residential)”.

### 5.9.1 Materials

Private drain connections shall be constructed of flexible pipe PVC DR28. On private property, materials for sanitary building sewers and private sewers shall comply with Part 7 of the OBC.

### 5.9.1.1 New Pipe Connections

- Concrete Pipe: core drilled KOR-N-TEE flexible connection (125 to 250 mm)
- PVC Pipe: fabricated tees

### 5.9.1.2 Connections to Existing Pipe

- Concrete Pipe: core drilled KOR-N-TEE flexible connection (100 to 250 mm)
- PVC Pipe: fabricated tees

## 5.9.2 Location

PDCs to single unit and semi detached lots are to be located in accordance with Figure D-1 “Standard Servicing Locations for Single Unit and Semi-Detached Lots”. PDCs to multi-unit (town housing, row housing and apartments), commercial and industrial blocks are to be connected to a maintenance hole on the R.O.W.

PDCs shall be installed at 90° to the sewer main where possible. Under no circumstances will flow from the PDC enter the main against the flow in the main. Where horizontal or vertical bends are required, long radius sweeps shall be used. Short bends are not acceptable. Single unit and semi detached lot sanitary PDCs shall NOT be connected to a maintenance hole.

PDCs for future sanitary sewers may be required by the municipality for lots that are to be serviced in the future.

## 5.9.3 Minimum Size and Grade

- The minimum diameter and grade of a PDC for a residential, single unit and semi-detached lot is 100 mm @ 2.0%.
- The minimum diameter and grade of a PDC for a residential multi-unit block is 150 mm diameter @ 1.0%.
- The minimum diameter and grade of a PDC for a non-residential block is 150 mm diameter @ 1.0%.
- The minimum diameter and grade of a PDC for a commercial block is 150 mm diameter @ 1.0%.
- The minimum diameter and grade of a PDC for an institutional block is 200 mm diameter @ 1.0%.

**Note:** The actual size of the PDC required for multi-unit, non-residential, commercial, and institutional blocks is dependent on the flows.

#### **5.9.4 Connections to Sewers/Maintenance Holes**

- **Residential**

- PDCs 100 mm and 150 mm in diameter must be connected to the main sewer using a premanufactured tee. Residential sanitary PDCs are not to be constructed into any sanitary maintenance hole.

- **Multi-unit, Commercial, Institutional, and Industrial**

PDCs are to be connected to the main sewer with a new maintenance hole(s).

- **Connections to Existing Sewers for Lot Infill Situations**

In a situation where a lot severance or lot infill condition exists, and a new sanitary service will be connected to an existing sanitary mainline, the advocate of the severance/infill, or his agent, must determine if the existing sanitary sewer is a combined or poorly separated sewer and is therefore at risk of surcharging, or if the sewer is a dedicated sanitary sewer but has a history of surcharging. If it is determined that there is a surcharge risk, the development advocate must provide surcharge protection to his development.

When connecting PDCs to existing sewers in a lot infill situations, connections must be made utilizing a premanufactured tee, in accordance with OPSS 410.

#### **5.9.5 Vertical Clearance**

A minimum clearance of 150 mm under/over the storm sewer and watermain is to be provided. For PDCs that cross over or under a watermain larger than 450 mm diameter, 600 mm clearance is required.

#### **5.9.6 PDC Cleanouts**

PDC Cleanouts are not permitted on Public, or Private Property under any circumstances.

On private property, sanitary building sewers and private sewers shall be provided with inspection/ maintenance holes, in accordance with Part 7 of the OBC. Inspection/ maintenance holes shall be located outside of the right-of-way.

#### **5.9.7 Marking and Recording PDC Service Connections**

Brown painted surface stakes 40 mm X 90 mm (standard 2" X 4") shall be placed after trench restoration to mark the termination of sanitary PDCs. These stakes shall extend from PDC invert to minimum 750mm above finished boulevard grade. Refer to Figure S-12 "Private Drain Connection Marker (Residential)".

Plugged or capped service connections shall be marked on the top surface of the last 3m of the upstream end of the pipe with yellow PVC adhesive tape (50 mm wide) labeled continuously in black lettering (40 mm wide) "**CAUTION SANITARY SEWER**"

- New PDCs to Existing Properties – To be constructed to property line.
- PDCs to Parklands – The location and design to be reviewed and approved by the Director of Public Works.

## **5.10 EASEMENTS**

Easements are required for all sewers to be assumed by the municipality located outside a road allowance on privately owned property. Easements are to be of sufficient width to ensure the sewers or municipal services can be properly installed and maintained by the appropriate authority (municipality or private). An easement provides the right to use private land for a specific purpose which is in the public's interest. All maintenance holes located within easements require hard surface access. Refer to Section 8.0 of this manual for more information.

## **6.0 WASTEWATER PUMPING STATIONS**

### **6.1 DESIGN CRITERIA**

#### **6.1.1 General**

The design peak sanitary flows are to be developed in accordance with the current Municipal Design Standards and the Ontario Building Code. Pumping station design is to be in accordance with MECP Design Guidelines for Sewage Works 2008 or current version – Chapter 7 Pumping Stations except as revised within these standards. The building design, layout, construction materials and stand-by power requirements shall be to the satisfaction of the Director of Public Works. Major design criteria elements shall be approved by the Director of Public Works at the preliminary engineering design stage and prior to proceeding to detailed design.

#### **6.1.2 Site Layout and Servicing**

Pumping stations are to be located outside any regulatory 100-year flood limits. The site shall have good vehicular access and maneuvering area and minimize potential adverse environmental impacts. Layout of facilities should allow for future expansion, and comply with front, rear and side yard set-backs according to the applicable zoning and site plan standard and requirements, and convenient location of portable generator. Building construction should be architecturally pleasing, in relation to surrounding community, and low maintenance. All permanent structures shall be masonry or concrete construction. Cladding for temporary structures shall be of pre-formed FRP or pre-finished metal. Include provisions to protect the building from vehicles. Other items for consideration include:

- Building insulation requirements, interior finish, and minimum interior building temperature control requirements shall be as directed by the Director of Public Works.
- Facility design and layout shall have regards to making confined space entry user friendly, optimizing sight and retrieval lines and comply with OHS A regulation.
- Landscaping of the site shall be low maintenance and architecturally pleasing, well-graded, minimal grass areas and landscaped to the satisfaction of the Director of Public Works. Site drainage shall not drain onto adjacent private property.
- Consideration is to be given to visual screening. The site and orientation of the facility is to be selected to minimize noise and odour impacts on adjacent properties.
- Fencing shall be chain link with lockable gates that are sized appropriately. Include warning and municipal address signage as per current municipal standards. Fencing shall follow by-law 49-2019, and directions provided by the Director of Public Works.

- Provide adequate exterior security lighting of the pumping station facilities such as access, and parking. Exterior lighting may be controlled by motion sensor or “photo-eye”. Consideration is to be given to shielding stray light into adjacent residential areas.
- Provide security hardware and alarms for all exterior doors, windows and exterior equipment.
- All control equipment and panels shall be indoors. Weather proof enclosures may be approved for smaller pumping stations.
- All utility meters such as gas, hydro, water meter reader, shall be mounted on the exterior of the building.
- Access to the site shall include provision for parking of maintenance vehicles and standby/emergency equipment. Roads shall be asphalt surfaced in parking and maneuvering areas and provide convenient removal and storage of snow, and turn around for trucks, tankers and heavy equipment.
- All utilities including phone and computer communications servicing the site shall be underground unless otherwise authorized by the Director of Public Works.
- Design, installation and planning of services shall be according to requirements of applicable codes, regulations and the local utility authority.

### **6.1.3 Structural**

The pumping station shall be evaluated for uplift and resistance to all combined or single loadings considering soil conditions, ground water level, and frost action. Uplift shall be determined when the structure is completely empty and dry, free of equipment, roof slab removed, and the structure watertight. Design the base slab to withstand all earth loadings when the structure is filled to maximum level, roof slab on, and all equipment installed. Provide crane and hoist design including appropriately sized hatches for convenient pump and equipment removal. Location of crane, hoist, and hatches, and arrangement of piping, pumps and equipment shall be designed to facilitate the removal and installation of equipment.

### **6.1.4 Flow Capacity**

The pumping station flow capacity shall be based on the peak hourly flow rate determined from the peak flow calculation in accordance with current municipal standards. Consideration is to be given to low flow conditions, future growth potential and potential staging of pumping capacity to match flows. The flow capacity of the pumping station shall be able to maintain a desirable cleansing velocity of 0.9 m/s with a minimum velocity of 0.60 m/s, and a maximum velocity of 3.0 m/s in all piping. The design of new pumping station should allow for future modification or expansion to meet the requirements of the tributary area of the pumping station.

### **6.1.5 Pumps**

Multiple pumps shall be provided and sized to provide firm capacity. When two pumps are used, firm capacity shall be maintained by one pump and should be of the same size. When multiple pumps are used, firm capacity should be maintained by the remaining pumps when the largest pump is out of service. The capacity of the largest pump will be equal to the required firm capacity. All pumps must undergo a hydrostatic and operating test performed by the manufacturer prior to installation.

Pumps handling raw wastewater should be capable of passing spheres of at least 76 mm diameter. Suction and discharge openings shall be at least 100 mm in diameter. Pumps should be positioned so that under normal operating conditions, they will operate under a positive suction head. When the pump is a suction-lift type, it should be a self-priming or a vacuum-priming type pump. Electrical equipment and components such as motors, lights, cables, conduits, switch boxes, control circuits, etc., shall comply with the Ontario Electrical Safety Code (OESC), CSA approved, and comply with the municipal requirements. Equipment located in wet wells, or in enclosed or partially enclosed spaces where there may be hazardous concentrations of flammable gases, vapours, or in the wet well shall also be suitable for use under corrosive conditions. Provide each flexible cable with a watertight seal and separate strain relief. A fused disconnect switch located above ground shall be provided for the main power feed for all pumping stations. Equipment exposed to weather shall be weatherproof, with lightning and surge protection. Include a 110-volt 15 amp receptacle for maintenance inside the control panel for lift stations that have control panels out of doors. Ground fault protection is required for all outlets located outdoors and in wet areas, on separate circuits with GFCI breaker for monthly testing and logging.

Each pump should have a separate intake. The configuration of the wet well and pump intakes shall prevent vortex formation and air locking. Dry well sump is to be equipped with two sump pumps to remove leakage or drainage and discharge above the maximum high-water level of the wet well. Provide dual check valves and gauges on discharge and suction lines for each sump pump. Water ejectors are not be connected to a potable water supply. Provide drainage for all floor and walkway surfaces. Pump-seal leakage shall be piped or channeled directly to the sump. Size the sump pump to convey the maximum pump-seal water discharge that would occur in the event of a pump-seal failure and provide necessary alarm activation. Consideration is to be given to the use of variable pump delivery rates for larger pump stations (> 50 l/s) and pumping stations operated as part of treatment facilities. The minimum efficiency, duty life, type and materials of construction for pump and impeller shall be approved by the Director of Public Works. Preferred voltage is 600 VAC, 3PH. Pump controls and SCADA requirements are to be reviewed and approved by the Director of Public Works at the preliminary design stage.

### **6.1.6 Valves and Fittings**

Provide suitable shut off valves on the suction line of dry pit pumps. Pump suction lines should be designed using 90 degree short radius down-turned flared elbows; wall pipe shall be flanged with water stop collar; all valves including eccentric reducer shall be flanged; all flanges welded; minimum pipe size shall be NPS-4. All isolation valves shall be located inside chambers for access. Shutoff and check valves with suitable guards are required on the discharge line of all pumps except screw type pumps. Locate

check valves between the shut off valve and pump. Use appropriate check valves and install horizontally on the discharge piping. Ball checks may be installed vertically on the discharge pumping. All valves shall be capable of withstanding normal pressure and water hammer. All valves shall be operable from the floor level and be readily accessible for maintenance. Use outside levers for swing check valves with suitable guarding. All valves, valve operators, fittings, concentric increasers, elbows, double branch elbows, and risers shall be flanged, all flanges welded. Spacers shall be 150-300 mm long with one flanged end and one grooved end for Victaulic coupling. Valves, check valves, drains, fittings and headers shall be of stainless steel, 316 or better, construction. Pipe materials shall be approved by the Director of Public Works. Identification including flow direction of all piping is required. Painting of non-stainless piping is also required.

### **6.1.7 Flow Measurement**

Flow measurement devices are required for all pumping stations and properly located for accurate readings with valving and fittings for maintenance with minimum downtime. Flow monitoring equipment shall be able to determine and record rate of flow, duration, volumetric sum, and frequency for each pump and each bypass, and interface with Municipal SCADA requirements. Provide a spool piece for each mag meter and provide a spool piece for each bypass as directed by the Director of Public Works. The spool piece depends on forcemain location and wet well retention time. If it is determined that enough time is available to remove the forcemain and install a spool piece safely, then a forcemain by-pass would not be required.

### **6.1.8 Wet Wells**

The volume of the wet well shall be based on the design average flow with a filling time not to exceed 30 minutes unless the pumping station is designed to provide flow equalization. When the wet well is designed for flow equalization, provisions to prevent septicity shall be included. Factors to consider when determining the size are:

- The volume required for pump cycling based on the pump manufacturer's duty cycle recommendations.
- Appropriate dimensions to minimize turbulence; vertical separation between pump control points.
- Sewer inlet elevation.
- Capacity required between alarm levels.
- Basement flooding and overflow elevations.
- Number, spacing and size of pumps.

The high water level shall be set 300 mm below the invert of the inlet sewer and the low water level shall be 300 mm minimum or twice the pump suction diameter above the centreline of the pump volute. The

wet well floor should have adequate slope to the intake hopper and the horizontal area of the hopper is to be kept to a minimum. Provision for air displacement in wet wells shall be made by natural means consisting of 0.10% of the well cross-sectional area, or a minimum two 100 mm diameter inverted “j” or gooseneck pipes with insect screens extending 900 mm above finished grade. One vent pipe is to extend to within 300 mm above the obvert of the inlet sewer. The other vent pipe should extend to the underside of the wet well roof slab. Wet wells are to be designed to be self-cleaning to minimize grit accumulation.

### **6.1.9 Ventilation**

Adequate ventilation, as per O.H.S., Building Code and NFPA shall be provided for all pumping stations. Underground dry wells and wet wells with screens or mechanical equipment require mechanical ventilation. The ventilating fan should be orientated to direct fresh air into the wet well at a point 900 mm above the alarm level rather than just exhaust from the wet well. Interconnection between the wet well and dry well is not allowed and vents shall not open or be connected to any building ventilation system. Where continuous ventilation is required, air shall be pre-heated. Consideration for the installation of air scrubbers shall be made as directed by the Director of Public Works. For dry wells, over 4.6 m deep, multiple air inlets and outlets should be used. Dampers, fine screens or other obstructions are not to be used on exhaust or fresh air ducts. Other items include:

- Switches and controls to operate ventilation equipment shall be conveniently located and marked. All intermittently operated ventilation equipment shall be interconnected with the respective lighting system. Consideration should also be given to automatic controls where intermittent operation is used. The manual lighting and ventilation switch shall override the automatic controls.
- The fan blades shall be fabricated from non-sparking material. Automatic heating and dehumidification equipment shall be designed for all dry wells.
- Wet well ventilation may be either continuous or intermittent. Continuous or intermittent ventilation shall meet or exceed the number of complete air changes per hour as required by NFPA 820. Air shall be forced into the wet well by mechanical means rather than solely exhausted from the wet well. The air change requirements shall be based on 100 percent fresh air. When permanent ventilation equipment is not practical, portable ventilation equipment shall be designed for use at submersible pump stations and wet wells.
- Dry well ventilation may be either continuous or intermittent. Continuous or intermittent ventilation shall meet or exceed the number of complete air changes per hour as required by NFPA 820. A two-speed ventilation system may be used to conserve heat. The air change requirements are based on 100 percent fresh air.

### **6.1.10 Water Supply**

A potable water supply is to be provided to the station unless otherwise directed by the Director of Public Works. Water supply shall be equipped with back-flow preventers to prevent contamination of the water system and all plumbing shall conform to the Ontario Building Code. Water supply shall be a minimum 25 mm.

### **6.1.11 Access**

Provision shall be made to facilitate easy and efficient removal of pumps, motors, and other mechanical and electrical equipment. A suitable and safe means of access for persons wearing self-contained breathing apparatus shall be provided to wet and dry wells and valve chambers.

Stairs shall be provided for vertical heights greater than 1.2 metres. Maximum vertical distance between work platforms and landings shall be 3 metres. Safety landings shall be constructed as work platforms.

Provide davit base anchors where required for standard equipment that complies with confined space standards. Equipment such as access hatches, ladders, service platforms, guards, grates and handrails, shall be constructed of a suitable material when exposed to wet/and or corrosive conditions.

## **6.2 EMERGENCY OPERATION**

The objective of emergency operation is to prevent the discharge of raw or partially treated wastewater to any waters and to protect public health by preventing back up of wastewater and subsequent discharge to basements, streets, and other public and private property.

### **6.2.1 Emergency Power**

Emergency power is required for all pumping stations. There shall be sufficient capacity of emergency power to start up and maintain the total confirmed pumping capacity of the station, the SCADA system and all other electrical equipment. All pumping stations shall be equipped with an onsite generator. In addition, a gen-set plug compatible with existing Municipal generators may be required as directed by the Director of Public Works. The pumping station is to be equipped with an automatic transfer switch to accommodate the "power-on" condition when normal power is returned to the facility. Generators should be capable of running full station load powered by natural gas or diesel as directed by the Director of Public Works and meet all applicable regulations.

### **6.2.2 By-Pass Overflows**

By-pass overflow shall be provided by gravity to existing storm sewer system or allow for emergency pumping to other gravity outlet. Emergency sanitary sewer overflow (SSO) outletting upstream of a SWM facility or directly to a SWM facility is not permitted. By-pass and overflow monitoring and totalization is required.

### 6.2.3 Instructions and Equipment

Wastewater pumping stations and portable equipment shall be supplied with a minimum of two complete paper sets plus one digital copies of all operational instructions, including emergency procedures, maintenance schedules, and such tools and spare parts as may be necessary. An 11x17" plastic laminate fact sheet, mounted to the wall of the pumping station or in an exterior control panel is to be provided for each station. The fact sheet is to contain the following information: overflow pipe data including size, location, and flow rates at 25, 50, 75 and 100% pipe capacity; lowest basement elevation; the hydraulic grade line for the pumping station and forcemain; process flow diagram indicating valves and interlocks.

## 6.3 FORCEMAINS

At design pumping rates, a desired cleansing velocity of at least 0.90 m/s shall be maintained. The minimum force main diameter for raw wastewater shall not be less than 100 mm. Air relief valves to be provided at high points in the force main to prevent air locking. Vacuum relief valves may be necessary to relieve negative pressures on force mains. The force main configuration and head conditions shall be evaluated as to the need for and placement of vacuum relief valves.

Fittings and isolation valves to be stainless steel. Design shall include transient analysis and consider the provision of water hammer relief. Forcemains shall enter the gravity sewer system at a point not more than 200 mm above the flow line of the receiving maintenance hole. The functional design details regarding the design of the forcemain are to be reviewed and approved by the Director of Public Works at the preliminary engineering design stage for the pumping station.

An assessment of residency time within the forcemain and the potential for hydrogen sulphide generation is to be undertaken having regard for low flows due to underdeveloped tributary areas. Where warranted, treatment measures are to be identified and their implementation is to be approved by the Director of Public Works.

Pipe and joints shall be equal to water main strength materials suitable for design conditions. The force main, reaction blocking, and station piping shall be designed to withstand water hammer pressures and associated cyclic reversal of stresses that are expected with the cycling of wastewater pumping stations. Forcemain pipe materials shall be approved by the Director of Public Works . Forcemain construction near streams or water works structures and at water main crossings shall meet applicable requirements.

Friction losses through force mains shall be based on the Hazen and Williams formula or other acceptable methods. When the Hazen and Williams formula is used, the following value for "C" shall be used regardless of pipe material:

Pipe Diameter (mm)	C-Factor
100 - 150	100
200 - 250	110
300 - 600	120
> 600	130

When initially installed, forcemains may have a significantly higher "C" factor. The forcemain shall be appropriately identified when they are constructed of material that may cause the force main to be confused with potable water mains. It shall be tested to ensure there is no leakage. Pressure and leakage tests to be completed to AWWA standard tests for watermains.

## **6.4 SAFETY**

The design of the pumping station shall give due regard to safety for the protection of maintenance personnel and visitors from hazards. The station site is to be enclosed with chain link fence, lockable gates, designed to discourage entry by unauthorized persons and animals; provide safety, unauthorized entry and municipal address signage. Other safety considerations include:

- Handrails and guards are to be installed around tanks, trenches, pits, stairwells, and other hazardous areas.
- Gratings are to be installed over areas where access for maintenance is required.
- Confined space entry shall comply with OSHA regulations. Facility design and layout shall have due regard to make confined space entry user friendly, optimizing sight and retrieval lines.
- Gas detection and monitoring equipment are to be provided where required. Where gas alarms are provided, install an indicator light outside the building so that the operator can check gas levels before entering the building.
- Portable ventilation and blower equipment, intrinsically safe, with sufficient hose, where required.
- Portable lighting equipment intrinsically safe, where required.
- Appropriately placed warning signs for slippery areas, non-potable water fixtures, low head clearance, open service maintenance holes, hazardous material storage areas, flammable fuel storage areas, etc.
- Adequate ventilation in pumping chambers.
- Provisions for lockout and tag-out of mechanical and electrical equipment.
- Eyewash fountains and safety showers where required. Fire extinguishers and emergency lighting are to be provided.

## **7.0 WATER DISTRIBUTION**

### **7.1 GENERAL**

These specifications apply to all water services and to all water mains up to 450 mm diameter including appurtenances which are located within the Municipal Road allowance, or on property which will be transferred to the Municipality. These specifications shall also apply to all water meter placements. The qualified person shall design to Thames Centre Specifications and also make reference to the Ministry of the Environment, Conservation and Parks “Design Guidelines for Drinking-Water Systems” and to the Ministry of the Environment, Conservation and Parks “Watermain Design Criteria for Future Alterations Authorized Under a Drinking Water Works Permit”. If there is a discrepancy between Thames Centre Specifications and the MECP Guidelines, then the Public Works Department shall be contacted to resolve the issue. Any deviation from these specifications must be submitted in writing to the Thames Centre Public Works Department for approval.

Materials, installation, hydrostatic testing, swabbing, flushing and disinfection shall be done in accordance with the Municipality of Thames Centre Design Specifications, MECP Drinking Water Regulations, AWWA Guidelines, the Thames Centre Municipal Drinking Water Licence and Thames Centre Drinking Water Permit.

For water mains larger than 450 mm diameter and for any other water system installation, special specifications must be prepared for and approved by the Director of Public Works. These specifications are to be used as a supplement to all other specifications approved by the Director of Public Works for water system installation. The water distribution system is for the purpose of supplying and distributing water and does not include plumbing or other works subject to the Ontario Building Code. “Water Distribution System” means watermains with connections to feeder watermains, feed watermains within subdivision lands, private watermains, water services, fire hydrants, and shut-off valves and all other appurtenances thereto. A water distribution system may exist for the purpose of distributing potable or non-potable water. However, water distribution systems for potable and non-potable water may not be intermixed or cross-connected. Private supplies of potable water may not be cross connected to the municipal or public water distribution system.

### **7.2 WATERMAIN DESIGN**

#### **7.2.1 Pressure and Flow Requirements**

Pressures are to be taken at the most critical locations. Watermains shall be sized to maintain the greater of:

- Maximum day demand plus fire flow at a pressure not less than 140 kPa (20 psi) at any hydrant lateral or potential fire service connection.

- Maximum hourly demand at a pressure not less than 275 kPa (40 psi) in residential areas and not less than 310 kPa (45 psi) in industrial areas.
- Average day demand at a pressure not less than 275 kPa (40 psi) in residential areas.
- Maximum residual pressure shall not exceed 550 kPa (80 psi) and a minimum residual pressure shall not be below 275 kPa (40 psi).

## 7.2.2 Design Water Demands

The Average day domestic (residential) unit demand for design shall be 350 litres per capita per day. The minimum hour, maximum day and peak hour peaking factors are to be based on existing flow data or in accordance with Table 3.1 of the Ministry of Environment's Conservation and Parks "Design Guidelines for Drinking-Water Systems". An excerpt is provided below for convenience.

Population		Minimum Rate Factor (Min. Hour)	Maximum Day Factor	Peak Rate Factor (Peak Hour)
500	1,000	0.40	2.75	4.13
1,001	2,000	0.45	2.50	3.75
2,001	to 3,000	0.45	2.25	3.38
3,001	10,000	0.50	2.00	3.00
10,000	25,000	0.60	1.90	2.85

For **domestic** water demands use the following densities:

Type of Use	People/Unit
Low Density Residential	3
Medium Density Residential	2.4
High Density Residential	1.6

**Commercial, institutional, and industrial** demands vary greatly with the type of facilities using water or process present in the development. Demands may be based on the specific use. However, consideration also must be given to the potential redevelopment of the site. If specific use data is not available, demands are to be based on the Ministry of the Environment, Conservation and Parks "Guidelines for the Design of Water Distribution Systems." The designer can also provide typical demand and peaking factor data.

Any deviations from the above require written authorization from the Director of Public Works.

## 7.2.3 Friction Factors

The following Hazen-Williams "C" values shall be used for design, regardless of material:

Pipe Diameter (mm)	C-Factor
100 – 150	100
200 – 250	110
300 – 600	120
> 600	130

## **7.2.4 Fire Demands**

To estimate the fire flow requirements for an area of the Municipality, the designer shall consult the Fire Code (O. Reg. 213/07) and the guide “Water Supply for Public Fire Protection A Guide to Recommended Practice” (latest revision) prepared by Fire Underwriters Survey. For single unit detached low density residential areas, a minimum fire demand of 76 l/s is to be used. On private property, adequate water for firefighting shall be determined in accordance with the Ontario Building Code.

## **7.2.5 Minimum Pipe Sizes/Acceptable Pipe Sizes**

The minimum size for watermains shall be 150 mm diameter except beyond the last hydrant on cul-de-sacs where smaller diameter pipe shall be used which is designed for domestic and maximum hour demands only.

Accepted pipe sizes are 50 mm and 100 mm (see above), 150 mm, 200 mm, 250 mm, 300 mm, 400 mm, 450 mm. Larger sizes require written authorization from the Director of Public Works.

## **7.2.6 Water Quality**

Watermains and watermain networks shall be designed so that water shall not remain unused in the watermain for more than three (3) days under average day demand. To demonstrate a three (3) day turnover, the designer shall provide a hydraulic analysis as outlined in Subsection 7.12 of this document. The hydraulic analysis shall also provide calculations to determine if and where automatic flushing devices are required and determine the appropriate size of the automatic flushing device (25 mm or 50 mm).

The Municipality has primary responsibility to ensure that the minimum chlorine residuals are maintained in the distribution system and therefore reserves the right to require watermain looping and/or automatic flushing devices and/or blow-offs to facilitate the maintenance of the chlorine residual.

On private property, where there is concern that a (3) day water turn-over cannot be achieved, the Municipality reserves the right to require premise isolation. This shall consist of appropriate backflow protection to the risk posed and it shall be installed at the property line and at the owners' expense.

It will be a requirement that a testable device (DCVA) be installed at property line for all site plans with a private watermain connected to the municipal water supply system which services more than one commercial/industrial building. The testable devices (DCVA) are to be maintained in accordance with the manufacturer's suggested requirements at the owner's expense.

## **7.2.7 Maximum Velocities**

The watermain shall be sized so that the maximum velocity in the pipe shall not exceed 1.5 m/s during maximum hour domestic flow conditions or 2.4 m/s during fire flow conditions.

## **7.2.8 Boundary Conditions**

For the purposes of hydraulic analysis, the designer shall use information from fire flow test directly.

## **7.3 LAYOUT OF WATERMAIN**

### **7.3.1 Watermain Location within Road Allowance**

- a) Watermains are to be located in the standard location as indicated on Figure R-1 “Typical Cross Section Urban Local Road” and Figure D-1 “Standard Servicing Locations for Single Unit and Semi-Detached Lots” unless otherwise approved.
- b) On watermain bends, the watermain may deviate from the standard location by up to 1.0 m, provided that the deviation is towards, or closer to the street line.

### **7.3.2 Watermain Pipe Depth**

For urban sections (w/ curb and gutter), watermains shall have no less than 1.7 m or more than 2.2 m of cover from final surface grade. For rural or unimproved roads, watermains shall be laid 2.1 m minimum below road grade or 1.1 m below the bottom of the ditch, whichever is greater. On unimproved roads within developed areas, the designer shall also review the vertical alignment of the road in order to assure that future road improvements will not result in an unacceptable watermain depth, as defined in this specification.

### **7.3.3 Pipe Insulation**

Where the pipe is to be laid with less than 1.7 m of cover, insulation shall be placed to prevent freezing in accordance with OPSD 1109.030. Where storm drains or culverts cross over or under a watermain, insulation is required per OPSD 1109.030 unless there is a minimum 1.7 m separation.

### **7.3.4 Pipe Offsets/Bends/Deflection**

Offsets where required are to be completed in accordance with Figure W-2 “Standard Mechanical Joint Offset Installation”. Use of offsets must be indicated on the approved plans or in the case of unforeseen obstructions found after approval of the watermain design, written approval of the Director of Public Works must be obtained. For watermain with a diameter up to 400 mm, a maximum bury depth of 2.3 m shall be utilized. Situations deviating from this shall be approved by the Director of Public Works.

If using joint deflection, full lengths of pipe must be used. The allowable maximum deflection for various pipe materials to be 50% of the manufacturer’s recommended maximum deflection. Where it is not possible to lay pipes to the required radius utilizing allowable joint deflection, manufactured pipe bends must be used. Axial deflection (bending of the pipe barrel) is prohibited for any pipe. Any change in the direction of the watermain in excess of the pipe joint deflection tolerance shall be made using an appropriate fitting. Thrust or joint restraint shall be provided per Section 7.3.7.

### **7.3.5 Termination of Watermains**

Watermains shall be terminated opposite street lines or property lines. Where caps and plugs are installed without a blow-off to provide for future watermain extension, a 20 mm watermain stop shall be tapped into the watermain no further than 0.5 m from the cap or plug to release trapped air/pressure from the watermain prior to removal of the cap or plug.

### **7.3.6 Blow-Offs / Automatic Flushing Devices / Addressing Water Quality**

The design of the watermain shall be undertaken to ensure adequate water quality requirements are met. Refer to Section 7.12 for requirements relating to Hydraulic Modelling. Dead ends of watermains to be provided with a blow-off in accordance with Figure W-4 “Standard 50 mm Blow-Off Installation”. Where caps and plugs are installed without a blow-off to provide for future watermain extension, a 20 mm watermain stop shall be tapped into the watermain no further than 0.5 m from the cap or plug to release trapped air/pressure from the watermain prior to removal of the cap or plug. On cul-de-sac or similar streets, blow-offs, when required, shall terminate in the boulevard. Blow-offs must be operable without the necessity of excavating.

Dead end watermain which are part of an interim phase of a subdivision build-out shall meet water quality requirements by:

- i. demonstrating adequate turnover by use; or
- ii. installation of an automatic flushing device.

Where an automatic flushing device is used to maintain water quality, Figure W-5 “9800 Automatic Flushing Device Detail” and Figure W-6 “Metered Automatic Flushing Device Detail”, a water meter (in a meter pit) shall be installed to measure the volume of water discharge. The owner will be charged for the water used. The designer shall provide calculations which indicate the volume of water to be discharged by the automatic flushing device and the sizing of the automatic flushing device as well as indicate the timer settings to be used. This information shall be clearly indicated on the drawings. The Owner’s contractor shall initially set up the automatic flushing device to the indicated settings.

Where an automatic flushing device is not required to maintain water quality, a standard 50 mm blow-off will be required to allow flushing to take place. On cul-de-sac or similar streets, blow-offs, when required, shall terminate in the boulevard. Blow-offs must be operable without the necessity of excavating.

### **7.3.7 Thrust Restraints**

Thrust restraint shall be provided at all fittings, bends, tees, valves, hydrants, crosses, reducers, and plugged or capped dead ends in accordance with Figure W-3 “Typical Restraint Details”. They shall be designed to adequately provide the minimum amount of pipe/joint restraint required by mechanical joint

restraint device alone. All restrained lengths must be clearly shown on the construction drawings. Concrete thrust blocks are not an accepted method of thrust restraint.

Thrust restraints shall be designed to be adequately provided by mechanical restraint devices. The following chart displays the minimum restraint length for horizontal bends and can be used to assist in design of mains of a maximum diameter of 300 mm. For mains larger than 300 mm diameter or installation situations not included in the table, the restrained length shall be shown on the shop drawings as recommended by the pipe manufacturer.

Main Diameter (mm)	Minimum # of Steel Rods	Minimum Length to be Restrained on Each Side of the Fittings (m)				
		11¼°	22½°	45°	90°	Dead End
100	2	4.0	4.0	4.0	4.0	20.0
150	2	4.0	4.0	4.0	5.5	20.0
200	2	4.0	4.0	4.0	7.0	20.0
250	4	4.0	4.0	4.0	8.5	20.0
300	4	4.0	4.0	4.0	10.0	20.0

Further to the above-mentioned design criteria the following requirements must also be met when designing thrust restraints:

- For watermains larger than 300 mm or installation situations not included in the above, the restrained lengths shall be shown on the construction drawings as recommended by the pipe manufacture and reviewed and or approved by the Director of Public Works.
- Hydrostatic test pressure is 1035 kPa (150 psi).
- For poly wrapped DI pipe refer to AWWA C600.
- For PVC pipe refer to AWWA C900, UNI-BELL and pipe suppliers manuals.
- Depth of bury is at a minimum of 1.7 m (5.5 ft).
- Stainless steel rods are to be a minimum of 20 mm in diameter.
- If any joint is encountered in the above restrained lengths, it must be restrained also.
- Fire hydrants shall be restrained as shown on Figure W-1 “Hydrant and Valve Installation”.
- Tie rod and clamp assemblies shall be installed in accordance with Figure W-2 “Standard Mechanical Joint Offset Installation”. All bolted assemblies must be free of concrete encasement.

### 7.3.8 Watermain and Other Utilities Separation

Designers shall refer to Ontario Ministry of the Environment’s Conservation and Parks “Design Guidelines for Drinking-Water Systems” (latest revision) and the Ontario Plumbing Code (latest revision) regarding

the location of watermains and water services relative to sewers and to the Public Utilities Act of Ontario regarding the location of watermains relative to other utilities. Encroachment of utilities, structures, sewers, and/or any utility appurtenances, which may impact the watermain, the integrity of its bedding, and/or structural capabilities, shall have design consideration(s) applied to adequately protect the watermain.

### 7.3.8.1 Parallel Installations of Watermains and Sewers

Sewers and watermains located parallel to each other shall be constructed in separate trenches maintaining the maximum practical horizontal separation. Under normal conditions, watermains shall be laid with at least 3.0 m horizontal separation from any sewer or sewer maintenance hole, or other appurtenance. The distance shall be measured from the outside diameter of each pipe.

In situations where this requirement cannot be met, alternatives which meet the requirements of the MECP Procedure F-6-1 Procedure to Govern the Separation of Sewers and Watermains for Parallel Installations shall be followed.

Link to MECP Procedure F-6-1

<https://www.ontario.ca/page/f-6-1-procedures-govern-separation-sewers-and-watermains>

### 7.3.8.2 Crossings of Watermains and Sewers

The designer shall refer to the Ministry of the Environment, Conservation and Parks Procedure F-6-1, Procedures to Govern the Separation of Sewers and Watermains.

#### Watermains up to and Including 450 mm Diameter

Watermains shall cross above sewers and Private Drain Connections (PDCs) with a minimum vertical separation of 0.60 m to allow for proper bedding and structural support of the watermain, sewer or PDC. If the watermain is less than 1.7 m below grade at the crossing, the watermain shall be insulated.

Where it is not possible for the watermain to cross above the sewer or PDC, the watermain shall pass under a sewer or PDC and shall be protected by providing all of the following:

- A vertical separation of at least 0.6 m between the invert of the sewer or PDC and the crown of the watermain.
- That a minimum 5.0 m length of water pipe shall be centered at the point of crossing so that the watermain joints will be equidistant and as far as possible from the sewer or PDC.
- Adequate structural support for the sewers to prevent excessive deflection of joints and setting.

#### Watermain Larger than 450 mm Diameter

Watermains shall cross above sewers and private drain connections (PDCs) with a minimum vertical separation of 0.60 meters to allow for proper bedding and structural support of the watermain, sewer, or PDC. Joints for the watermain shall be located a minimum horizontal distance of 2.0 meters from the crown of the sewer pipe or PDC. If the watermain is less than 1.5 meters below grade at the crossing, the watermain shall be insulated. Where it is not possible for the watermain to cross above the sewer or PDC, the watermain shall pass under a sewer or PDC and shall be protected by providing all of the following:

- A vertical separation of at least 0.60 meters between the invert of the sewer or PDC and the crown of the watermain.
- Adequate structural support for the sewers to prevent excessive settling and/or deflection of joints.
- A minimum 5.0 meter length of water pipe be centered at the point of crossing so that the watermain joints will be equidistant and as far as possible from the sewer or PDC.

### **7.3.9 Looping of Watermain/Supply Redundancy**

Water distribution systems have to be designed to exclude any dead-ended pipe unless meeting the requirements in Section 7.3.6. Water distribution systems ought to be designed so that no more than eighty (80) units with individual water services and meters are serviced from a single source of supply. If the looped watermain is connected to a single watermain, a valve must be installed in the watermain to permit isolation of supplies. For requirements for looping for private property, see Section 7.7.1.

## **7.4 MATERIAL**

### **7.4.1 Reference Specifications**

All waterworks material used shall be new and shall conform to the latest revision of the Standards of the American Waterworks Association (AWWA). No other materials other than those listed herein may be used. Should any supplier or contractor wish to explore alternate materials, submission for Approval is to be submitted to the Municipality. The review of a submission for approval of alternate materials may require a significant amount of time on the part of the Municipality. Parties making submissions should allow for such time requirements.

The Municipality reserves the right to select any materials or product it deems appropriate for the application. It also reserves the right to remove from the specifications any product previously approved but found inappropriate for the application. This includes but is not limited to pipe material, valves, or fittings. The design engineer shall clearly indicate on drawings and contract documents the materials which are acceptable for use in a particular application where the use of one or more of the approved materials list is not acceptable. Unless otherwise specified, the watermain test pressure shall be 1035 kPa (150 psi).

The Municipality reserves the right to require proof, to its satisfaction, that all products and materials that come into contact with drinking water meet NSF/ANSI 61 standard as well as all other applicable standards.

## **7.4.2 Transitions in Pipe Materials – Watermains**

Transitions from one pipe material to another must be made at a valve or tee. Where PVC pipe is used, a tracer wire must be provided along the entire pipe and CAD welded to the valve and terminated at grade elevation.

## **7.4.3 Watermains**

All PVC pipe and PVC fittings are to be blue in colour.

Polyvinyl Chloride (PVC) pipe up to and including 300 mm diameter shall conform to AWWA C900, bell wall thickness to conform to AWWA C900 to be certified by the Canadian Standards Association to CSA Standard B137.3, shall be, DR 18 with Cast Iron outside diameter dimensions and, the words 'Factory Capped' are to be included in the print line of every pipe. Approved AWWA C900 Pipe (100 mm to 300 mm):

- Ipex Blue Brute
- Royal Pipe Royal Seal
- Next Polymers Aqualoc

Polyvinyl Chloride (PVC) pipe sizes larger than 300 mm up to 600 mm in diameter shall conform to AWWA C905 Class 165, DR 25 (minimum) as determined by the Design Engineer, bell wall thickness to conform to AWWA C905 to be certified by the Canadian Standards Association to CSA Standard B137.3 and have Cast Iron outside diameter dimensions and the words 'Factory Capped' are to be included on the print line of every pipe. Pipes greater than 600 mm diameter are not approved for use in Thames Centre. Approved AWWA C905 Pipe (up to 600 mm):

- Ipex Centurion
- Royal Pipe Royal Seal
- Next Polymers Aqualoc (400 mm)

Tracer wire shall be #12 AWG Copper Clad Steel, High Strength with minimum 450-pound break load, with minimum 30 mil HDPE insulation thickness supplied along the full length of the pipe to provide electrical continuity for location purposes.

Fittings shall be PVC injection-moulded fittings with push on joints (for use with PVC and PVCO pressure pipe conforming to AWWA C900, CSA B137.3, having cast iron O.D) and are to conform to the AWWA

Standard C907. Moreover, fittings are to be UL listed, FM approved, and certified by the Canadian Standards Association to CSA Standard B137.2. Approved AWWA C907 Fittings:

- Ipex
- Royal
- Harco

Ductile Iron push-on fittings are not approved for use with PVC pipe. Mechanical joint Ductile Iron AWWA C110 fittings shall be used when they are an integral part of the restraining system. Ductile Iron watermain pipe is not approved for use in Thames Centre.

#### **7.4.4 Valves**

- Watermain valves shall be resilient-seated gate valves and shall conform to AWWA C509/C515 standard they must have an iron body, bronze mounted, non-rising stem, double-disc for buried service.
- Valves located within the **THORNDALE** system are to **OPEN** counter-clockwise; a stainless steel plate indicating the direction of opening is to be provided for each valve.
- Valves located within the **DORCHESTER** system are to **OPEN** clockwise; a stainless-steel plate indicating the direction of opening is to be provided for each valve.
- An extension rod and screw type valve box are to be supplied for every valve; extension rods are to extend to 150 mm to 300 mm below finished grade.
- Valves typically are to be located in line with the extension of the property limit line.
- Valves 100 to 200 mm in diameter to have bell ends; valves 250 to 450 mm need to have mechanical joint ends.
- Valve flanges, bonnets, nuts, bolts and washers to be protected from corrosion using Denso paste, mastic and petrolatum tape.

#### **7.4.5 Hydrants**

- Hydrant to AWWA C-502 for dry barrel with push on joints to ANSI/AWWA C111/A21.11; with breakable flange.
- Hydrants located within the **THORNDALE** system are to **OPEN** counter-clockwise.
- Hydrants located within the **DORCHESTER** system are to **OPEN** clockwise.
- Each hydrant to be controlled by a gate valve located in front of the hydrant.

- All underground metallic surfaces to be protected from corrosion using Denso paste, mastic and petrolatum tape.
- Fire hydrants located within municipal right-of-way shall have a chrome YELLOW high gloss exterior paint over quick dry red oxide primer.
- Fire hydrants located on private property shall have a fire engine RED high gloss exterior paint over quick dry red oxide primer.
- All new fire hydrants shall be three-way with two (2) standard hose connections and one (1) STORZ connection with black cap. STORZ nozzle to be bronze ASTM B584, nozzle cap to be cast iron.
- Approved hydrants:
  - Canada Valve Century
  - McAvity Hydrant M-67

#### **7.4.6 Services**

- Residential services to be 25 mm in diameter; type Rehau Municipex or Ipex Blue 904.
- Services greater than 25 mm to 50 mm in diameter; type Rehau Municipex or Ipex Blue 904.
- Services to be installed in accordance with Figure W-7 “Standard Installation of < 50 mm Water Service”.
- Services 100 mm and larger to be PVC pipe, Figure W-8 “Schematic Layout of 100 mm and Larger Services”.
- Service saddle to be provided for all PVC pipe; 25 mm service to 100 mm DI; and 40 mm to 50 mm services to any DI and CI main.
- Curb stops to be located 300 mm from property line on street side, they shall have stainless steel cotter pins.
- Main cock and curb stop to **OPEN** counter clockwise.
- All underground metallic surfaces to be protected from corrosion using Denso paste, mastic and petrolatum tape.
- Approved curb and main stops:
  - Cambridge Brass
  - Ford

- Mueller
- Megatite

### **7.4.7 Tracer Wire**

Tracer wire to be installed on all non-metallic watermains, hydrants laterals and water services except where such water service pipe is of copper material. The wire must be installed in such a manner as to be able to properly trace all watermains, hydrant laterals and water services without loss or deterioration of signal or without the transmitted signal migrating off the tracer wire. For trenchless installations refer to OPSS 450.

All tracer wire welds onto existing cast of ductile iron pipe shall be completely sealed with the use of Chace/Royston Handy Cap IP. In all cases, the pipe is to be properly cleaned and material shall be applied in accordance with the manufacturer's instructions.

Approved direct bury connectors: SnakeBite Locking Connector LSC 1230 and Pro-Trace TW Connector.

All slices or repaired wire connections in the tracer wire system shall be made using waterproof connectors specifically rated for underground applications. Tracer wire shall have a Zinc anode installed as per OPSS 442 Table 5. Tracer wire shall be terminated as per Figure W-10 "Tracer Wire Installation".

### **7.4.8 Sampling Station & Auto-Flusher**

All sampling stations shall be installed as per the manufacture's specifications. Approved Sampling Stations and Auto Flushers:

- Model Eclipse #88-SS-R as manufactured by Kupferle with the Extreme cold climate option.
- Model Eclipse #9800 as manufactured by Kupferle with the Extreme cold climate option.

## **7.5 LOCATION AND SPACING VALVES**

### **7.5.1 Location and Spacing of Watermain Valves**

In accordance with the Ministry of the Environment, Conservation and Parks, Watermain Design Criteria for Future Alterations Authorized Under a Drinking Watermain Works Permit, Table 2: Shut-Off Valves.

#### **7.5.1.1 Residential Developments**

Low and Medium Density Residential Developments, valves shall be located so that any section of watermain serving up to a maximum of fifty (50) residential water services can be isolated by operating not more than four (4) valves. Valves shall be located on all intersecting streets in line with property line. Phasing of developments should be considered, and valving should be logical (i.e. at intersections). In residential areas, valves shall be spaced no more than 240 m apart.

### **7.5.1.2 High Density Residential, Commercial and Industrial Developments**

In high density residential, industrial, and commercial areas, valves shall be located to be no more than 150 m apart.

### **7.5.1.3 Feeder Watermains**

Feeder watermains (400 mm, 450 mm, and 600 mm) shall have valves at 400 m intervals.

### **7.5.1.4 Intersections of Watermains**

At intersections where smaller watermains connect to larger feeder watermains, each smaller watermain shall be valved with an isolation valve whereas the larger watermain shall be valved as required above.

### **7.5.1.5 Valves for Looped Services/Private Watermains**

Valves shall be installed on looped services or private watermains to isolate buildings or groups of buildings so that no more than fifty (50) individual water services or apartment complex containing 150 dwelling units or more are on any one valved section. The Owner shall install a valve on the street watermain between connections to a looped private watermain if there is not an existing valve, at no expense to the Municipality.

### **7.5.1.6 Crossings of Watermain, Rivers, Railway, Controlled Access Highways, Bridges**

Watermains crossing rivers, railways and controlled access highways shall be valved on each side of the crossing.

### **7.5.1.7 Location of Valves at Intersections with Roundabouts**

Water valves may be placed within the raised roundabout island where possible. However, if placement of the valves creates a potential conflict with the curb & gutter of the island, then the valves are to be placed in the boulevard clear of the curb and gutter of the approaching streets.

## **7.5.2 Valve Locations – Phasing of Subdivision Developments**

The location and number of valves shall take into consideration reducing shutdowns and inconvenience to customers during the construction of additional phases. Valves may be installed on a temporary basis and relocated in order to accomplish this.

## **7.6 FIRE HYDRANTS AND FIRE DEPARTMENT CONNECTIONS**

All fire hydrants situated within the road allowance are the sole property of the Municipality of Thames Centre and are to be maintained by and operated by the Municipality of Thames Centre. Hydrant and valve installations shall be in accordance with Figure W-1 “Hydrant and Valve Installation”.

All new PUBLIC hydrants installed are to be flow tested and colour coded in accordance with the requirements of NFPA 291. Colour coding is for the purpose of indicating available fire flows at 20 psi residual pressure. Colour coding shall be by means of placing round 0.090 thick HDPE material fabricated using 3M high intensity reflective vinyl applied as per the NFPA 291 Colour Chart and adhered to the reflectivity standards of ASTM D-4956 Type IV retro-reflectivity markers on each of the two 65 mm hydrant outlets as manufactured by B.M.R. Manufacturing Inc.

Class	Rated Capacity		Colour
	USGPM	L/min	
<b>AA</b>	≥ 1500	≥ 5680	Light Blue
<b>A</b>	1000 – 1499	3785 – 3780	Green
<b>B</b>	500 – 900	13900 – 3780	Orange
<b>C</b>	≤ 500	≤ 1900	Red

### 7.6.1 Location/Spacing of Hydrants on Public Streets

The location of hydrants is subject to the requirements and approval Thames Centre Fire Department in accordance with the Ontario Building Code. Generally, hydrants must be located no more than 170 m apart along the length of the watermain and shall be located at intersections where possible. For a more detailed discussion of hydrant spacing requirements refer to Fire Underwriters, “Water Supply for Public Fire Protection a Guide to Recommended Practices” (latest edition).

### 7.6.2 Hydrants on Dead-end Streets

Hydrants shall not be located on dead-end streets unless such streets exceed 90 m in length. Where located on dead-end street the hydrant shall be located at 90 m from the end and a smaller size watermain (minimum 50 mm) shall be used beyond the hydrant so that water quality is maintained.

### 7.6.3 Addition of Relocation of Hydrants

Regardless of hydrant location shown on accepted subdivision plans, additional hydrants may be required or existing hydrants may have to be relocated due to circumstances unknown at the time of plan acceptance such as the position of a structure, Fire Department connection, driveway or landscaping feature. Such addition and/or relocation shall be requested when the Municipality approves the service plan and must be done at the expense of the Owner of the subdivision or, if the subdivision has been assumed, at the expense of the Owner of the property for which the additional or relocated hydrant is required.

### 7.6.4 Protection of Hydrants

If the placement of a hydrant on public or private property is such that it will be susceptible to damage by vehicular traffic, bollards are to be installed, at the owner’s cost, in sufficient number to protect the hydrant. Minimum spacing between any bollard and a hydrant shall be 1.0 meter, and bollards shall be a

minimum of 1.0 meter in height. Bollards to be painted hydrant chrome yellow and construction to be steel with concrete fill.

## **7.7 WATER SERVICES, FIRE SERVICES AND PRIVATE WATERMAINS**

For all water service pipe and fire service mains on private property, the Ontario Building Code shall apply. It shall be noted that water quality requirements are not addressed in the Ontario Building Code. Where there is a concern that there may be a degradation of water quality in the private servicing that has the potential to enter the municipal water supply system, the Thames Centre Public Works Department reserves the right to require premise isolation. Premise isolation shall consist of appropriate backflow prevention measures to the risk posed and shall be installed at the property line at the owner's expense.

The following section applies to the water services on public property up to the property line:

- The Owner will be responsible for water service sizing. Thames Centre Public Works Department is to be consulted for available pressures and flows at the watermain under design conditions.
- On private property, adequate water required for fire protection shall be determined in accordance with the Ontario Building Code. Fire flow and hydraulic calculations shall be reviewed by the Municipality's Building Division.
- It is a requirement to provide fire flow information (i.e. hydrants on private property and fire sprinkler requirements) in conjunction with site plan submissions for water servicing to determine the correct water service sizing.
- The minimum size permitted for water services is 25 mm diameter.
- Water services larger than 25 mm diameter may be required for estate lots, larger homes, deep setbacks or where automatic lawn sprinkler systems or fire sprinkler systems are to be used.
- In accordance with the Ontario Building Code and NFPA 24, the minimum size for fire service mains and water service pipes, combined with fire service mains, shall be 150 mm.
- Where the main pressures within the municipal system exceed 690 kPa (100 psi), pressure reducing valves are to be installed by the owner at no cost to the Municipality.
- Residential water services to be installed in accordance with Figures W-7 "Standard Installation 20 mm to < 50 mm Water Service; and Figures W-8 "Schematic Layout of 100 mm and Larger Services".
- Anodes to be installed on all steel components of a watermain in accordance with Figure W-9 "Magnesium Anode Configuration for various Metallic Fittings".

### **7.7.1 Looped Water Servicing Required**

A looped water service connected to a public or private watermain or watermains must be installed:

- When one water service will not supply the required flow for domestic use and fire protection.
- For an apartment complex containing one or more structure and more than 150 dwelling units.
- For a townhouse, condominium or similar complex having more than fifty (80) units with individual water services and meters.

The looped water servicing must be installed to service the private development from two sources. If the looped watermain is connected to one public watermain, an isolating splitter valve must be installed in the public watermain to permit isolation of supplies, at no cost to the Municipality. Water service shall be of an approved material type to the property line. On private property, material for water service pipes and fire service mains shall comply with Part 7 of the Ontario Building Code.

## **7.7.2 Layout of Water Services**

The standard residential water service stub will be located in accordance with Figure D-1 “Standard Servicing Locations for Single Unit and Semi-Detached Lots”. The water service pipe must be installed at right angles to the watermain and in a straight line from the watermain to the water meter. Services connected to a private watermain are subject to the same requirements as water services connected to a public watermain. They must have no less than 1.7 m and no more than 1.9 m of cover from final surface grade. Water services and private watermains are to be located so that “berm” or “mound” type landscaping will not cause excessive cover over water services.

### **7.7.2.1 Separated Water and Fire Services**

Domestic water, sprinkler and standpipe services may be installed as a separated services from the watermain to the structure. Sprinkler and standpipe services may be combined. The Owner is advised to consult with the Insurance Underwriter before combining these services.

### **7.7.2.2 Combined Water and Fire Services**

A domestic water service may be combined with a sprinkler or standpipe service or with a combined sprinkler/standpipe service. The Owner is advised to consult with the Insurance Underwriter before combining these services. The owner/designer is advised that water quality shall be considered; domestic water demands may not achieve a sufficient turnover rate to prevent poor water quality.

## **7.7.3 Water Service Valves**

All water services shall be equipped with a corporation stop and a curb stop. The curb stop shall be provided with a curb box. All water service valves and curb stops shall be installed with valve boxes and operating rods.

### 7.7.3.1 Location of Water Service Valves

- Water services to structures in a complex that are to be connected to a private watermain shall have the curb stop or valve placed 3 meters (10 feet) from the face of the building, if this distance locates the curb stop in the paved portion of the complex, a deviation in the curb box location may be requested.
- The layout for water services must be such that the curb stop or valve can be easily found by referring to two directional dimensions from a plaque located on the building where the water service enters.
- The Owner shall ensure that water service control valves on their property are not covered by “mound” or “berm” type landscaping.

### 7.7.4 Water Service Entrances

Water services of all sizes shall enter through the building wall or under the wall footing into a heated area, leaving sufficient pipe and working space for meter installation. A length of between 0.3 m and 0.45 m shall be exposed above the finished floor. The pipe shall enter the building not less than 0.15 m and not more than 0.3 m from the wall.

### 7.7.5 Protection from Contamination

Connections to the municipal potable water system shall be designed and installed so that non-potable water or other substances that may render the water non-potable, cannot enter the system in accordance with the requirements of the Ontario Building Code. The Owner may be required to install a backflow preventer on the water service to prevent backflow into the watermain in the event of a loss of pressure in the system. The Owner will be responsible for the supply, installation and maintenance of all backflow preventers and protective devices, at no cost to the Municipality.

### 7.7.6 Electrical Grounding

Electrical systems of all new developments shall not be grounded to the water system. Refer to Ontario Hydro Electrical Safety Code (Section 10) for grounding requirements. Where an existing watermain is replaced or upgraded, the grounding of electrical systems to the water service may not be adequate. It will be the Owner’s responsibility to ensure grounding is adequate after the watermain is installed.

## 7.8 CORROSION PROTECTION

Where ductile iron, steel or concrete watermain pipe are to be used, soil samples shall be taken on each street to identify soil class and resistivity for the purposes of designing corrosion protection systems for these pipe materials. The corrosion protection systems for the watermain shall be designed by a consulting engineer who is NACE (National Association of Corrosion Experts) Certified.

## **7.9 EASEMENTS**

Easements are required for all watermains to be assumed by the municipality located outside a road allowance on privately owned property. Easements are to be of sufficient width to ensure the sewers or municipal services can be properly installed and maintained by the appropriate authority (municipality or private). An easement provides the right to use private land for a specific purpose which is in the public's interest. Where a watermain is installed on an easement which is located on private property or between private properties which have or may have a building(s) located on the property(ies) in the future, the watermain shall be installed in a casing. Refer to section 8.0 of this manual for more information.

## **7.10 INSTRUMENTATION**

For design and installation standards related to instrumentation and control equipment, the Designer must consult the Director of Public Works for current "Scada and Instrumentation Standards".

## **7.11 WATER METERS**

### **7.11.1 General Requirements**

All domestic water services must be metered. Fire services are not metered with the exception of sprinkler systems located in individually metered dwelling units.

### **7.11.2 Supply of Water Meters and Water Meter Remote Read Registers and Meter Strainers for Services 150 mm and Larger**

The Municipality will supply and install all water consumption meters that are used for billing process. Strainers for 75 mm and larger installations where required shall be supplied by the Municipality.

### **7.11.3 Location of Water Meter**

Water Meter Location shall be in accordance with Figure W-11 "Standard Installation of Water Meters Less than 25mm" and Figure W-12 "Typical Installation for 40mm and 50mm Disc Type Water Meter".

The water meter shall be installed on the water service immediately inside the point of entry of the water service into the building. Any variation from this location must be approved in writing by the Director of Public Works. The Owner shall provide sufficient space for installation and maintenance of the meter. The meter must be accessible for reading and maintenance and must be protected from freezing and other damage. The meter or piping shall be no closer than 1 m to any electrical panel or above or below any electrical panel unless provided with a meter enclosure.

#### **7.11.3.1 Meter Pits Requirements**

Meter pits will be allowed only with approval of the Director of Public Works when no other suitable location is feasible. Meter pit design and installation must be submitted for approval meeting the Materials

requirements of this specification. All costs associated with the supply and installation of the meter pit will be the responsibility of the Owner.

## 7.11.4 Installation of Water Meters

Water meters less than 25 mm size for single unit residential units with individual water services, will be supplied and installed by the Municipality. Water meters 25 mm and larger in size shall be supplied by the Municipality, installed by others, and charged to the property owner. Water Meters shall be installed in accordance with AWWA C700, C701 or C702.

### 7.11.4.1 Water Meter Valving

All new installations shall require a valve on each side at the meter. The Owner must supply and install the valves for all sizes of meters and the inlet valve when the water service piping is over 25 mm diameter. The Owner will be responsible for maintaining and keeping the meter inlet and outlet valving operational and in good working order. All meter setting valves must open left (counterclockwise).

### 7.11.4.2 Meter Strainers

Meter strainers shall be supplied and installed by the Municipality on 75 mm size and larger meter installations. The Owner shall consult the Engineer regarding dimensions of supports required for the meter and strainer.

### 7.11.4.3 Water Meter-by-pass Requirements

The Owner shall install, at his expense, a meter bypass when any of the following conditions exist:

- i. The water meter is 40 mm or larger in size.
- ii. Shutting the water supply off for approximately thirty (30) minutes during normal working hours of the Municipality would create a production or other problem to the Owner.
- iii. Any water service which supplies coin-operated equipment cannot be shut down for thirty (30) minutes or longer during the normal working hours of the Municipality.

## 7.11.5 Meter Sizing

The size of meters will generally be one size smaller than the water service. Owners shall obtain advice from the Engineer on meter sizing. Meter ratings are as follows:

Meter Sizing (mm)	Maximum Rating (l/min)	Continuous Rating (l/min)
16	76	38
20	114	57
25	189	95
40	378	189

50	606	303
Compound Meters (mm)	Maximum Rating (l/min)	Continuous Rating (l/min)
75	1136	568
100	1893	946
150	3785	1893

## 7.12 HYDRAULIC MODELLING

### 7.12.1 General

- Hydraulically water distribution system modeling is required for all new developments unless otherwise exempted by the Director of Public Works. Modelling reports and the results of the analyses are to be submitted to the Municipality for review as part of technical submissions for subdivision review. An electronic version of the hydraulic model is to be provided to the Municipality for review and for incorporation into the Municipality's overall hydraulic model.
- The model is to include all watermains 50 mm diameter and larger, control valves (pressure reducing valves and flow regulating valves), reservoirs and pumping stations.
- For phased developments, submit updated hydraulic models incorporating the distribution system for all phases at the first phase stage. The conditions for each phase of development are to be modeled independently.
- The Municipality may require hydraulic analyses beyond the development boundaries in situations where the operation of water system facilities such as control valves, reservoirs and pumping stations, are influenced by changing demands in the new development.
- The model shall also include calculations to ensure water quality in any dead end watermain at the end of a phase and specify the installation of automatic blow-offs or flushing devices, as required.
- The Municipality has adopted EPANET as its standard for hydraulic modelling. Other software packages may be used for analysis and reporting but all model input files provided must be directly compatible to EPANET without modification.
- As a minimum, steady-state hydraulic analyses for each proposed development phase are to be provided for the following demand conditions:
  - Average day
  - Peak hour
  - Maximum day plus fire flow (fire flows to be modeled at critical locations)

- Water quality detention time
  - All Hydraulic reports shall include detailed maps/layouts of the watermain system (valves, hydrants, etc.) and shall clearly show the pipe and node numbering

## 7.12.2 Design Criteria

In accordance with Section 7.2 Watermain Design.

### 7.12.2.1 Hydraulic Model Input Standards

#### Units

Parameter	Units
Elevation	m
Length	m
Diameter	mm
Demand	l/s
Tank Diameter	m
Tank Volume	m <sup>3</sup>
Pressure	m (of water)
Power	kw
Time	hr

#### Node Elevations

In metres to geodetic datum and estimated final grading contours.

#### Node and Link Identification

Nodes and links are to be graphically identified on a map.

#### Demands

Use average day demands and global demand multipliers for demand patterns.

## 7.12.3 Submission Requirements

Submit electronic versions of the following files in EPANET format:

- Model input file.
- Model Input File in Text Format with Tab Separation.
- Map or Shape File.

Submit a report, sealed by an Ontario Professional Engineer, including:

- Summary of demand scenarios and points of connection to the Municipal system.

- Network map which identifies node and link numbers.
- Node tables for all scenarios listing node numbers, elevation, demands, and pressures.
- Link tables for all scenarios listing link numbers (with up and downstream nodes indicated), diameters, lengths, roughness, velocities, flows, head losses, and age of water calculations
- For multi-phase developments, provide model data and summaries for all phases as part of the first phase submission.

Reports containing results that indicate operating parameters outside the acceptable Design Criteria will be automatically rejected without further review and returned to the Owner for correction.

#### **7.12.4 Review by the Municipality**

The Municipality will review the report and advise on the need for any further analysis to be carried out. All costs associated with the development of the model, report submissions and any modifications will be at the Owner's cost.

### **7.13 COMMISSIONING**

Hydrostatic testing, swabbing, flushing, disinfecting and bacteriological testing of watermains are to be carried out in accordance with the Ontario Watermain Disinfection Procedure and AWWA C651 (current version) and witnessed by the Water Operator. A watermain commissioning plan must be submitted to the Municipality for review and acceptance by the Director of Public Works at least 10 business days prior to any connection to the existing municipal system.

#### **7.13.1 Hydrostatic Testing**

Hydrostatic testing is to be conducted under the supervision of the Water Operator upon completion of the watermain including services and backfilling. Testing of new watermain and appurtenances (fire hydrants and laterals, etc.) including water services to the curb box is to be completed on new subdivision watermain infrastructure only. All other hydrostatic testing of new watermain replacements include the testing of all appurtenances including the installed service saddle 25 mm main stops only. All services over 25 mm are to be tested to the curb box. All caps and/or plugs used for testing process to be supplied, same for tap and ball valve.

Hydrostatic pressure and hydrostatic leakage tests may be conducted either simultaneously or separately. Duration of test shall be two (2) hours or longer if directed by the Water Operator if tests are performed simultaneously. If two tests are performed separately, conduct hydrostatic pressure test before hydrostatic leakage test.

- Duration of pressure test shall be one (1) hour or longer if so directed by the Water Operator.
- Duration of leakage test shall be two (2) hours or longer if so directed by the Water Operator.

The Contractor shall assume all responsibility when testing against existing or new line valves. They are to provide all bulkheads, taps, fittings and pipe thrust restraint necessary to undertake pre-qualification or final testing. Testing for Polyethylene Pipe shall be in accordance with the manufactured specifications and AWWA M55. The Contractor is to provide means of obtaining water.

- Fill test section slowly with water making sure that all air is removed from pipeline.
- A period of 24 hours is to be allowed before starting test.
- Subject test section to continuous test pressure specified for one hour or as directed by the Water Operator and in accordance with the Contract Administrator.
- Test pressure shall be 1035 kPa or as specified in the Contract. No pressure drop is allowed during the hydrostatic pressure test period.
- Examine all parts of test section while under pressure. If test pressure is maintained with no pressure drop for specified test duration, test result is satisfactory.

If the test result is not satisfactory, repair all deficient parts of section and retest until satisfactory result is attained. The temporary connection shall include a reduced pressure zone assembly that is tested, and it is to be disconnected from the new main during the hydrostatic pressure test.

### **7.13.2 Swabbing and Flushing**

Watermains shall be swabbed and flushed in a sequence and in accordance with procedure accepted by the Municipality and in accordance with the Contract Administrator. The contractor must submit a swabbing, flushing and disinfection procedure to the Water Operator for approval two (2) weeks prior to the operation for approval. Swab to be a minimum 4" (100 mm) larger than the diameter of the watermain being swabbed or as directed by the Water Operator.

All watermains up to 450 mm diameter shall be cleaned by the use of a minimum of four (4) foam swabs introduced at special entry sections or as directed by Water Operator and forced by water pressure through the main to exit points approved by the Water Operator and in accordance with the Contract Administrator. Cleaning is to be repeated until 2 consecutive clean swabs (no discolouration of swab) and the discharge water is clear and approved by the Water Operator and in accordance with the Contract Administrator.

Hydrants laterals shall be manually swabbed using a chlorine slurry as directed by the Water Operator Method for swabbing watermains larger than 450 mm in diameter shall be as specified in the Contract. Mains must be cleaned or flushed before hydrostatic testing and disinfection is done.

### **7.13.3 Management and Disposal of Excess Material**

Management and disposal of excess material shall be according to OPSS 180.

## 8.0 EASEMENTS

An easement provides the right to use private land for a specific purpose which is in the public's interest. Easements are required for all municipal services outside of the road allowance or on privately owned property where the sewer is to be assumed or operated by the municipality. They must have sufficient width to ensure that the municipal services can be properly installed and maintained by the appropriate authority (municipality or private). Easement widths are to be calculated in accordance with Figure D-5 "Minimum Easement Width". Width is determined by the depth of cover from the centerline of the road/ground to the invert of a sewer or watermain. The minimum width of a sewer easement at a depth of up to 2.4 metres shall be 4.8 metres (2.4 metres on each side of the sewer). Where there is more than one utility, adequate width of easement and separation of utilities for both construction and future access and maintenance shall be provided.

Easements are not required for standard rear lot catch basins unless there is a significant external drainage component or where the catch basin is designed to receive runoff from municipal lands, parklands or open spaces. Maintenance vehicle access is not required for rear lot catch basin maintenance holes.

### 8.1.1 Types of Easements

#### a) Municipal Servicing Easements

Are required for watermains, wastewater & stormwater collection systems, catch basins, drains, stormwater management ponds, channels and/or access roads that cross a site and which are maintained by the Municipality.

#### b) Utility Easement

Utility easements are required for telephone, hydro, gas and cable television services. Each utility company shall be consulted for their specific requirements.

#### c) Private Easements

Private easements are required for private storm sewers, access roads and other private services that cross a parcel of land to service other private lands. A joint access and maintenance agreement between interested parties shall be entered into.

#### d) Temporary and Working Easements

Temporary easements are required for watermains, sanitary & storm sewers, drains, stormwater management ponds, channels and/or access roads that cross a site temporarily. The services in the easement are to be maintained by the owner of the services. Working easements may be required, as necessary during construction, to allow for the safe construction and restoration of the disturbed surface area. Once construction is completed, the working easement is released.



## **ENGINEERING DESIGN STANDARDS**

### **THE CORPORATION OF THE MUNICIPALITY OF THAMES CENTRE Easements**

---

Temporary easements are required for storm sewers and access roads that cross a site temporarily. The services in the easement are to be maintained by the owner of the services.

## 9.0 ROADWAYS

### 9.1 GENERAL

The road network indicated on Schedule "C" of the Thames Centre Official Plan is based on the inter-relationship of land use and transportation. The primary objective is to provide optimum conditions for the movement of people and goods from one portion of the Municipality to another as well as to facilitate the traffic movement through the Municipality. Every attempt shall be made to ensure that the Municipal Road pattern is in harmony with the Road System as well as those of adjoining municipalities and linkages to the Provincial Road System.

### 9.2 ROADS DESIGN

#### 9.2.1 Design Speed

- Urban: The Maximum Design Speed for local urban roads shall be 60 km/h with a posted speed of no more than 50 km/h.
- Rural: The Maximum Design Speed for local rural roads shall be 90 km/h with a posted speed of no more than 80 km/h.

#### 9.2.2 Road Classifications

Each road within the Municipality is not designed nor intended to serve the same function. The roads within the Municipality have been classified according to the anticipated ultimate function that each road would fulfil. Where additional land is required for widenings, extensions, or intersection improvements, such land shall be obtained wherever possible in the course of approving plans of subdivision, development applications, or by conditions attached to individual consents. Road Classifications shall be as noted in the Official Plan.

#### 9.2.3 Centreline Radii

- Collector and Local Streets

Collector roads and local streets shall have centerline horizontal curves in accordance with Figure R-4 "Minimum Centreline Radii of Curvature for Roads in Subdivisions". Local Streets with bends of approximately 90 degrees are to have a minimum inside street-line radius of 9.0 m. Bends of 90 degrees are only permitted on local streets. Bends are to be in accordance with Figure R-5 "90 Degree Curve – Local Street".

- Reconstruction Projects

The reconstruction of existing roads is to have the centreline horizontal and vertical alignments reviewed by the Director of Public Works.

## 9.2.4 Radii for Curb and Gutter

Intersection Radii for curb and gutter shall be measured at edge of pavement. The following chart illustrates the required radii.

		Arterial/Primary Collector (m)	Secondary Collector (m)	Local (m)
<b>From:</b>	<b>Arterial</b>	15	15	12
	<b>Collector</b>	15	15	9
	<b>Local</b>	7.5	7.5	7.5

- Intersection Radii Day-lighting Requirements

A 3.0 m day-lighting triangle is required where a 15.0 m radius is needed at the intersection of a collector street to a collector street; a 6.0m day-lighting triangle is required when on any road type connection to an arterial road.

- Cul-de-sacs

The minimum required radii of curvature for curb & gutters are to be in accordance with Figure R-6 “Standard for Circular Cul-de-Sac” and Figure R-7 “Industrial Cul-de-Sac”

## 9.2.5 Local Residential Street – Urban Cross Section

The standard cross section for local urban roadways is to be in accordance with Figure R-1 “Typical Cross-Section Local Urban Residential Street”.

## 9.2.6 Local Residential Street – Rural Cross Section

The standard cross section for local rural roadways is to be in accordance with Figure R-2 “Typical Cross-Section Local Rural Residential Street”

## 9.2.7 Industrial Cross Section

The standard cross section for industrial roadways is to be in accordance with Figure R-3 “Typical Cross-Section – Industrial Roadway”

## 9.2.8 Multi-Lane Roadways and Channelized Intersections

For multi-lane roads or channelized intersections, minimum lane widths shall be based on the following chart.

Description	Width (m)
Right Turn Lane	3.0
Left Turn Lane	3.0
Through Lane	3.5
2-way Left Turn Lane	4.0
<b>Note:</b> In situations with higher design speeds or higher road classifications, wider lanes may be required.	

### 9.2.9 Right of Way and Pavement Widths

Pavement widths and Right of Way widths shall be based on the following chart. All pavement measurements are edge of pavement to edge of pavement.

Category	Usage	R.O.W. (m)	Pavement (m)
Major	Arterial	36	varies
	Primary Collector	26	varies
Minor - Residential	Secondary Collector	21.5	9.5
	Local (Urban)	20	8.0
	Local (Rural)	20	7.0
Minor-Industrial and Commercial	Cul-de-sacs (<185 m)	26.1	9.7

The pavement width of Secondary Collectors shall be widened to 11 m when they connect to Primary Collectors and Arterials. The storage length shall be 45 m, taken from the end of the curb and gutter radii and the return taper shall be 30 m. The right-of-way at these widenings shall be increased to 22.5 m.

The pavement width of Local Roads serving 60 units or more shall be widened to 10 m when they connect to Primary Collectors and Arterials. The storage length shall be 30 m, taken from the end of the curb and gutter radii and the return taper shall be 30 m. The right-of-way at these widenings shall be increased to 21.5 m.

For reconstructed local roads: If the measurement of the existing road width is less than defined in the previous chart, then use the chart width. If the measurement of the existing road width is greater than 8 m, then reconstruct at 8 m.

### 9.2.10 Maximum and Minimum Road Grades

The maximum grade of any local road shall be 8%. The minimum road grades on all roads shall be 0.5%. The road cross-fall to be 2.0%.

Flat see-saw profiles (identical high and low points) will not be allowed in either road profile designs or rear yard swale designs. See-saw profiles must slope in a cascade that allows major storm flows to drain along the road or lots to an acceptable overland flow outlet.

In reconstruction projects within existing developed areas of the municipality, where the existing profile and driveway conditions cannot accommodate a cascading see-saw profile, the proposed profile must provide for adequate road drainage and be acceptable to the Director of Public Works.

## 9.2.11 Vertical Curves

Where the grade of a road with design speed of 70 km/h or less changes by more than 1% (or the grade of a road with a design speed of 80 km/h or more changes by more than 0.5%), a vertical curve conforming to the following requirements must be incorporated:

- Use “K” value from section 9.2.10.1 as long as all other requirements of the Geometric Design Standards for Ontario Highways are met.
- Vertical curve length in meters shall be numerically greater than or equal to the design speed in km/h.
- When matching new vertical curves into existing ones, match the K values to provide continuity.

### 9.2.11.1 “K” Values

On vertical curves, K factor shall be derived from the following table:

<b>Design Speed (km/h)</b>	<b>60</b>	<b>70</b>	<b>80</b>	<b>90</b>	<b>100</b>	<b>110</b>	<b>120</b>
<b>Crest Vertical Curve Minimum K<sup>1</sup></b>	15	25	35	50	70	90	120
<b>Sag Vertical Curve Minimum K<sup>2</sup></b>	18	25	30	40	45	50	60
1. Source: Geometric Design Standards for Ontario Highways, Table C4-6. 2. Source: Geometric Design Standards for Ontario Highways, Table C4-7.							

## 9.2.12 Drainage Issues

### Overland Flow Routes

- The design of all road profiles for New Development Projects are required to accommodate and direct major overland flow routes (OLFR) to an acceptable outlet. This design element is to be considered at the earliest stages of design, coordinating with Thames Centre Public Works Department for information, assistance, review and acceptance, all to the satisfaction of the Director of Public Works.
- The design of all major road profiles for Capital Works Projects (i.e. existing rural roads, Transportation EA’s, etc.) are required to consider major overland flow routes (OLFR) and where possible, accommodate and direct the OLF’s to an acceptable outlet. This design element is to be considered at the earliest stages of design, coordinating with Thames Centre Public Works

Department for information, assistance, review and acceptance, all to the satisfaction of the Director of Public Works.

- In reconstruction projects within existing developed areas of the Municipality, where the existing profile and driveway conditions cannot accommodate a formalized OLF Route, the proposed profile must provide for adequate road drainage and be acceptable to the Director of Public Works.
- In order of preference, OLFR shall be directed along:
  - a) arterial and primary collector roads
  - b) secondary collector roads
  - c) local streets
  - d) parks, open spaces

Culvert Under Roads

- New culverts or culverts that are being redesigned, replaced or impacted by road works/road widenings must be designed to meet the hydraulic requirements established by MTO for inlet or outlet control culverts.
- Municipal practice requires that culverts must convey, and bridges must accommodate, the minimum storm events as specified below:

Classification of Road	Minimum Storm Event to be Conveyed by Culvert
Local & Secondary Collector	25 Year Storm Event
Primary Collector & Arterial	50 Year Storm Event
Bridges	100 Year Storm Event or Regional storm event, subject to the Conservation Authority's conditions. Meeting more stringent criteria could be required depending on factors that include the road's classification.

- Information, coordination, and acceptance for this design element must be received and shall be considered at the earliest stages of design.

**9.2.13 Reserve Blocks**

Reserve blocks of 0.3 m are required:

- Along block frontages and at the rear and/or flankage of lots which are adjacent to arterial and collector roads.
- At the dead end of proposed road networks which abut future proposed road extensions or networks.

- Where roads in a subdivision abut lands outside the subdivision.

### 9.2.14 Rural Asphalt Lift Edge Taper

On all rural road cross-sections, asphalt in all lifts shall be laid so that the edge of pavement is inclined at a 45-degree angle. Base lifts of asphalt shall be laid wider than surface lifts, so that a consistent slope is maintained.

### 9.2.15 Pavement Structure

- Geotechnical Report: A geotechnical report shall be completed unless otherwise noted by the Municipality's Project Manager
- Maximum Benkalmen Beam Spring Rebound

Class of Road	Maximum Spring Benkalmen Beam Rebound (mm)
Local	1.90
Collector	1.25
Arterial	0.64
Expressway	0.50

- Municipal Projects

The pavement structure of all roads being constructed or repaired under a Municipal Project, and in New Subdivisions, shall be based on the following table:

Subgrade Type	Component	Local	Collector	Arterial
"Weak" Lacustrin Clay	Asphalt	90	130	180
	Gran. A	150	150	150
	Gran. B	300	450	600
	EGT	531	712	912
"Medium" Glacial Till	Asphalt	90	130	180
	Gran. A	150	150	150
	Gran. B	300	450	450
	EGT	531	712	812
"Strong" Clayey Gravel	Asphalt	90	130	180
	Gran. A	150	150	150
	Gran. B		150	300
	EGT	330	511	711

If the geotechnical investigation determines the native material is stronger & free draining, a reduction in the Granular B thickness could be considered.

**Equivalent Granular Thickness (EGT) Factors**

Class of Road	Maximum Spring Benkalmen Beam Rebound (mm)
Local	1.90
Collector	1.25
Arterial	0.64
Expressway	0.50
1. Source: TAC – Pavement Design and Management Guide, Table 6.5,6.6,6.7	

- Top-coat asphalt laid on all roads shall be placed over existing or freshly laid hot mix asphalt, cold in-place recycled, or milled asphalt, and shall have a minimum lift thickness of 40 mm.
- Granular A shall be placed at a minimum depth of 150 mm.
- A tack coat shall be applied on all milled surfaces and in situations where placement of asphalt lifts is separated by more than two weeks.

d) Asphalt Selection by Road Classification

Class of Road	Traffic Category	PGCA	Binder Asphalt	Surface Asphalt
Local	B	58-28	HL 8 or Superpave 19.0	HL 3 or Superpave 12.5
Collector	C	58-28	HL 8 or Superpave 19.0	HL 3 or Superpave 12.5
Arterial	D	58-28	HL 8 or Superpave 19.0	-
Arterial	D	64-28	-	HL 1 or Superpave 12.5 <sup>1</sup>

**Note:** Superpave Mix design as per OPSS MUNI 1151, Table 1 and Table 2. With approval from TP&D, Marshall Mixes (HL8, and HL3) may be used for minor tie-in work or slip-arounds for new Subdivisions, and maintenance repairs.

1. Subject to Surface Course Asphalt Policy (Section 9.2.14.e), this may need to be Superpave 12.5FC1.

e) Surface Course Asphalt Policy

Superpave 12.5FC1 is a premium surface asphalt mix with coarse aggregate that is more resistant to rutting and maintains good skid resistance. HL 4 is a coarser mix with slightly higher stability suitable for rural uses. HL3 and Superpave 12.5 are a finer mix with improved aesthetic qualities for use in urban applications with pedestrians and other active transportation uses.

Superpave 12.5FC1	<ul style="list-style-type: none"> <li>• 20,000 AADT <b>OR</b> Average Daily Truck Traffic &gt; 1,000 <b>AND</b> Pavement life expectancy of at least 10 years</li> </ul>
HL4	<ul style="list-style-type: none"> <li>• Rural applications</li> </ul>
HL3 and/or Superpave 12.5	<ul style="list-style-type: none"> <li>• All other applications</li> </ul>

f) PGCA

All Superpave 12.5FC1 applications shall use of PGAC 64-28 asphalt cement with a higher quality aggregate. The aggregate shall be on the MTO designated sources list. HL3 and Superpave 12.5 shall use PGAC 58-28, unless a higher grade PGAC is specified by the municipality.

### **9.2.16 Cul-de-Sacs**

The maximum length of cul-de-sac without an emergency or secondary access is 215 m. The minimum curb and gutter grade around a cul-de-sac shall be 0.5%. The maximum centre line road grade within a cul-de-sac shall be 3.0%. Cul-de-Sac to be in accordance with Figure R-6 “Standard for Cul-de-Sac” or for industrial applications refer to Figure R-7 “Industrial Cul-de-Sac”.

### **9.2.17 Turning Lane Requirements**

Where warranted a traffic impact study is to be completed to determine requirements for turning lanes, storage, and tapers. The length of the tapered and parallel portions of the turn lane shall be determined in accordance with the “Geometric Design Standards for Ontario Highways”.

### **9.2.18 Minimum Frontages**

At bends in streets or on cul-de-sacs, lots must be designed such that when side lines are projected to the fronting curb, an adequate frontage exists at the curb line to avoid conflicting driveway location. The minimum frontages at the curb line shall be:

- 5.5 metres for single unit lots.
- 9.0 metres for semi-detached lots.

### **9.2.19 Intersections**

#### **9.2.19.1 At Grade Road/Rail Intersections**

All railway crossings at grade in built-up areas shall be protected by the text warning sign “Cyclists Use Caution Crossing Tracks”.

#### **9.2.19.2 Road/Road Approach Grades**

Refer to TAC – Geometric Design Guide for Canadian Roads – Figure 2.3.2.2.

#### **9.2.19.3 Road Layouts**

When two (2) streets connect at an intersection they shall connect at 90 degrees with 10 metre straight sections measured back from the street line.

## **9.3 PARKING**

### **9.3.1 Parking Design**

When designing the layout of parking lots, the designer shall consider the turning requirements for delivery vehicles and emergency vehicle access. Adequate setbacks from property lines and they shall also consider queue development at the entrance, pedestrian flow through the parking area, and dropped curb with ramps at convenient locations for wheelchair accessibility.

### **9.3.2 Grading**

The grading shall provide for an overland flow route to an adequate drainage outlet without exceeding a ponding depth of 0.3 metres anywhere on the parking lot.

## **9.4 DRIVEWAYS**

### Urban:

- Driveway locations are to be shown on the grading drawings for all non-standard situations such as along curves, at the ends of cul-de-sacs or adjacent to twin inlet catch basins.
- Conflicts with surface utilities including streetlights, transformers, utility vaults, fire hydrants and catch basins are to be avoided.
- Driveways are to be in accordance with Figure R-11 “Single Family Driveway Entrances with Boulevard”, and/or R-12 “Standard for Single and Double Driveway Entrance (Urban)”.
- The maximum residential driveway width at the property limit is to be 6.0m.
- Residential, Industrial, Commercial, and Institutional driveways must have hot mix asphalt to property line.

### Rural:

- The maximum residential driveway width at the property limit is to be 6.0m. Driveways are to be in accordance with Figure R-13 “Standard for Single and Double Driveway Entrance (Rural)”.
- Only one standard driveway is to be provided for each residential property. Properties with greater than 35m of frontage can apply for an additional driveway access. Such applications will be reviewed relative to local conditions and will be subject to municipal approval.
- Agricultural field access will be limited to one 12.0 m access or two 6.0 m accesses per 25 to 50 hectare parcel. Agricultural access for parcels less than 25 hectares will be limited to a single 6.0 to 12.0 wide access. All access widths are measured at the property limit.

- Driveway culverts in settlement areas are to be sized to convey the 2 year municipal design storm unless the culvert forms part of a Municipal Drain system. Driveway culverts are not to be less than 300 mm in diameter.
- Driveway culverts shall be High Density Polyethylene (HDPE) or Corrugated Steel Pipe (CSP) and maintain a cover of at least 300 mm.
- Residential driveways in urban settlement areas must have hot mix asphalt to property line
- Industrial, Commercial, and Institutional driveways must have an asphalt entrance.

## **9.5 SIDEWALKS, BICYCLE LANES AND PEDESTRIAN WALKWAYS**

### **9.5.1 Sidewalks**

As a minimum, sidewalks are to be provided as follow:

- Local Street - one side \*
- Collector/Arterial - both sides
- Cul-de-sacs - subject to municipal review

\* In addition, the municipality may require additional sidewalks to provide linkages to parks, schools or any areas where an increase in pedestrian activity may be anticipated.

- Sidewalks to be in accordance with Figure R-8 “Concrete Sidewalk”:
  - Standard residential: 1.5 m wide; 125 mm concrete; 100 mm granular base
  - Commercial or heavy traffic entrance: 1.5 m wide; 150 mm concrete; 100 mm granular base
  - Integrated with curb: 1.8 m wide; 125 mm concrete; 100 mm granular base
  - Cross-fall: minimum 2%; maximum 4%
- All sidewalk ramps terminating at Municipal ROW shall meet AODA standards and have Cast iron tactile plates, rusted red in colour, installed in accordance to OPSD 310.031, 310.033 and 310.039, respectively.

### **9.5.2 Bicycle Lanes**

On-street bicycle lanes 1.5 m in width are to be incorporated into the road network; the designer is to review and confirm requirements with Thames Centre Public Works Department. The on-street bicycle lanes are to be as per the required pavement structure for the class of road on which the bicycle lane is being constructed.

### 9.5.3 Pedestrian Walkways

- Pedestrian walkways are to be designed and constructed in accordance with standard drawing R-10 “Standard Pedestrian Walkway”.
- When designing a standard 3.0 m or 4.6 m width walkway, ensure that the full width of the walkway is sidewalk and no grassed area.
- Walkway sidewalk to have a crossfall of 2%.
- Removable posts are to be installed at both ends of the walkway or as approved by the Director of Public Works.
- Privacy screen wood board fencing shall be constructed from the rear lot line to the front face of abutting structures to a height of 1.8 m. Black coated chain link fence shall be constructed along the balance length to the front property line.
- Pedestrian handrails are to be constructed on one side of the walkway in line with the removable posts where walkway grades exceed 8%.
- Sidewalk and concrete to have a minimum strength of 30 MPa with 5% to 7% air entrainment and low slump.
- Driveway locations to be located as far from the walkway as possible.
- A barricade and/or warning sign is required at the limit of a dead-end street and/or end of a proposed sidewalk on an existing right-of-way where the sidewalk terminates.
- A temporary sidewalk shall be constructed from the end of a proposed sidewalk to the adjacent road edge, at the curb & gutter or gravel shoulder as required by the Director of Public Works.

### 9.5.4 Curb and Gutter

#### Types and Applications

- Residential subdivisions: semi-mountable per OPSD-600.06.
- Arterial and primary collectors / commercial or industrial developments: barrier curb per OPSD-600.01.

#### Transition/Termination

- A transition of 3.0m is required between curb types.
- Curb termination as per OPSD 608.01 shall be used within temporary turning circles and dead end streets or intersections which abut or are adjacent to a future phase of a subdivision.

## 9.6 CATCH BASINS (ROAD WORKS)

### Locations:

- Upstream of any pedestrian crossing – centred on the lot line.
- Upstream curb returns at intersections.
- As otherwise appropriate at intersections located at curb returns.
- At a minimum of 90 metre intervals and a maximum 90 metres from crest in the road.

### Types:

- 600 x 1450 catch basin to be installed in all low points in the curb to be in accordance with OPSD 705.020.
- Standard 600 x 600 pre-cast roadside catch basins to be in accordance with OPSD705.010.
- Ditch inlet catch basins for ditch drainage, external drainage or temporary block drainage to be in accordance with OPSD-705.030 and OPSD-705.040.

### Leads:

- Street: 250 mm dia @ minimum grade of 0.69% (velocity 1.0 m/s).
- Lot/Rear Yard: 300 mm dia @ minimum grade of 0.54% (velocity of 1.0 m/s).
- Catch basin leads less than 15 metres in length are to be connected into the adjacent storm sewer.
- Catch basin leads between 15 metres and 30 metres in length can be connected to sewers 900 mm or larger; if the receiving sewer is less than 900 mm, a catch basin maintenance hole is to be used.
- Catch basin leads longer than 30 metres require a catch basin maintenance hole.
- Pipe and bedding to be in accordance with sewer pipe standard identified in this manual.

### 9.6.1 Frames and Grates

- Standard: OPSD-400.02
- Ditch Inlet: OPSD-403.01

### **9.6.2 Sub-Drains**

Sub-drains are required for all roadside catch basins to facilitate road sub-grade drainage;

- Minimum of 3.0 metres sub-drain on each side unless otherwise recommended by geotechnical engineer.
- To consist of 150 mm dia perforated PVC pipe wrapped in geotextile (270 Terraxfix or equal) or manufactured geotextile knitted sock.
- Sub-drain ends to be capped at upstream end with a pre-manufactured end cap sized to fit pipe.

## **9.7 PAVEMENT MARKINGS**

Pavement marking locations shall be designed in accordance with the Ontario Traffic Manual – Book 11. Proposed designs shall be submitted to the municipality for review and acceptance prior to construction. Application shall follow completion of top coat asphalt, within 24 hours. No catch basins to be located within residential/commercial entrances.

All stop signs shall have a white reflective stop bar with a yellow centerline extending 15.0 m back from the stop bar. 3M Stamark Series A440 or approved equivalent shall be used for stop bars, pedestrian crossings at intersections, pedestrian crossovers (PXO) and centerline.

### **9.7.1 Pavement Reinforcement**

Requirements for pavement reinforcements shall be addressed by the geotechnical engineer including all details.

### **9.7.2 Access configuration**

Single Unit accesses are to be in accordance with Figure R-11 “Single Family Driveway Entrances with Boulevard”. Should a conflict occur between the location of a driveway and the location of a catch basin (CB), then the Owner shall correct the conflict by either relocating the driveway, except when a parking plan governs, or reaching out to the Director of Public Works for approval of the catch basin location, and at no cost to the Municipality.

Development blocks for site plan approvals access configurations shall be in accordance with Ontario Provincial Standard Drawing 350.010, noting all Municipality’s specific requirements. No catch basins, existing or proposed shall be located within the limits of site entrances. In situations where existing catch basins would be within proposed site entrances, the access shall be realigned to avoid catch basins or the catch basin shall be relocated outside the access curb return.

### **9.7.3 Roadside Protection**

Roadside protection shall be applied in accordance with the Ministry of Transportation's Roadside Safety Manual.

### **9.7.4 Regulatory/Road signs**

Regulatory / Road Signs shall be applied in accordance with the Ontario Traffic Manual Book 5 and as supplied by Cedar Signs Incorporated, Cambridge, ON.

## **9.8 TRAFFIC CALMING**

### **9.8.1 Application and Methodology**

Traffic calming measures are applied on primary and secondary collectors in residential areas, and occasionally on local roads. If traffic calming measures are deemed necessary, based on an engineering report, they will only be applied after the completion of a comprehensive traffic calming plan which will address all matters relating to traffic calming within a designated area and after extensive public consultation.

### **9.8.2 Signage**

- Entrance points to areas in which traffic calming measures have been installed, shall be posted with the Traffic Calmed Neighbourhood sign. See Canadian Guide to Traffic Calming (2<sup>nd</sup> Edition). Appropriate signage may include, but is not limited to, Maximum Speed, Right or Left Turn Prohibited, One Way, and Stop signs.
- Street Name Signs, Traffic Control Signs and steel round post locations to be determined during the subdivision design review stage. Locations may be included on the streetlight design drawings or on stand-alone traffic control drawings.

### **9.8.3 Speed Cushions**

Speed cushions are used to reduce vehicle speeds, by causing discomfort to occupants of vehicles crossing them at high speeds. Speed cushions shall be made of HL3 Asphalt Mix, unless directed otherwise by the Director of Public Works. Refer to Figure R-15 "Speed Cushion Design".

### **9.8.4 Raised Crosswalk Design**

Raised crosswalks are crosswalks constructed in concrete to a height of 150 mm above the elevation of the street. Raised crosswalks are very effective at reducing vehicle speeds specifically where pedestrians will be crossing a street. Refer to Figure R-14 "Raised Pedestrian Crosswalk".

Note: Catch basins are to be provided at upstream end of raised crosswalks to allow for drainage.

### **9.8.5 Rights In/Rights Out Raised Concrete Median**

A right in/right out island should only be used in locations where it is very difficult/or impossible to implement on-street raised concrete median. A right in/right out island is roughly triangular, and placed in the centre of an intersection approach. A minimum size of 10 m<sup>2</sup> is required to provide pedestrian refuge. Both the in and out lanes shall be not less than 6m in width. The island shall be protected by barrier curb OPSD 600.01, except at pedestrian crossings. The signage shall be in compliance the Canadian Guide to Traffic Calming and Ontario Traffic Manual – Book 5.

### **9.8.6 Roundabouts**

A roundabout is a raised island located in the centre of an intersection, which requires vehicles to travel through the intersection in a counter-clockwise direction around the island. Roundabouts are to be designed as per *TAC – Canadian Roundabout Design Guide*.

All approaches to the circle shall be protected by a Yield sign, so that vehicles already traveling on the roundabout have right-of-way over vehicles entering it. A One Way sign Rb-21, indicating a counter-clockwise direction of travel, shall be installed on the centre island opposite each approach. For maintenance purposes, sanitary maintenance holes are not permitted to be located within the raised centre island of the roundabout. The sanitary maintenance hole is to be located within the apron of the island. Storm maintenance holes may be located within the centre island of the roundabout, provided the proposed landscaping does not hinder access to the maintenance hole.

## **9.9 STREET LIGHTING**

### **9.9.1 Warrants**

Street lighting shall be considered warranted on all roads in urban areas. At isolated rural intersections with non-continuous lighting on the intersecting roads, street lighting shall be considered warranted if the roadway meets or exceeds the requirements of the warrant provided in the Transportation Association of Canada Illumination of Isolated Rural Intersections guide.

Reconstruction of a substandard, isolated rural intersection should be considered before illumination. Street lighting may also be installed at isolated rural intersections at the direction of the Director of Public Works. Situations when this is warranted may include but are not limited to the occurrence of rare but severe collisions, an inability to maintain adequate hazard markings for raised channelizing islands, or the presence of an unusual number of long combination vehicles with reduced accelerating and braking abilities.

### **9.9.2 Materials**

- Decorative Pole Spec: KS-15-E-11-DB
- Fixture Spec: King LED – K118R-B3AR-IV-100(SSL)-1054-120:277-K6/K9-PR7-GH-SST-4K

### 9.9.3 Streetlight Design

- Design of street illumination on all roads shall be designed, signed and sealed by a qualified Professional Electrical Engineer that meets the criteria identified in the Registry, Appraisal and Qualification System (RAQS), conform to the requirements set out by ANSI/IESNA RP-8. Secondary Collectors and Local Design
- Residential Streetlight Designs shall conform to the requirements set out by American National Standard Practice for Roadway Lighting (ANSI/IESNA RP-8-18) and submitted with the final subdivision drawing submission.
  - Detailed photometric designs shall be submitted for all other roads, intersections and sidewalks demonstrating how the RP-8-18 standards have been satisfied without excessive over lighting. Illumination at intersections may require a higher wattage fixture than the remainder of the road. Contact the Director of Public Works to confirm the appropriate road classification and pedestrian conflict prior to undertaking the photometric design. In addition to the photometric drawings, the results of the photometric design must be displayed in a table similar to the following: (see table below)

	<b>Lavg</b>	<b>Lavg/Lmin</b>	<b>Lmax/Lmin</b>	<b>Lmax/Lavg</b>
Major Road with Medium Pedestrian Conflict	0.9	3.0	5.0	0.3
<b>Luminaire Name</b>				
	<i>RESULTS</i>	<i>RESULTS</i>	<i>RESULTS</i>	<i>RESULTS</i>
	Eh (lux/ft)	EVmin(lux/ft)	Eavg/Emin	
Sidewalk with medium pedestrian conflict	5.0/0.5	2.0/0.2	4.0	
<b>Luminaire Name (near side)</b>				
	<i>RESULTS</i>	<i>RESULTS</i>	<i>RESULTS</i>	
<b>Luminaire Name (far side)</b>	<i>RESULTS</i>	<i>RESULTS</i>	<i>RESULTS</i>	

- The drawings shall show the location of the streetlights (indicated by a bold open circle), streetlight conductors, the location of transformers and the location of power disconnects. The drawings shall specify the type of pole, fixture, conduit, fixture wattage, conductor and 20kv 10ka breakers being used.
- Once municipal approval has been obtained, the design is to be submitted to Hydro One for electrical approval and joint trench coordination. All costs associated with street lighting in new subdivisions is to be attributed to the developer.

- Street light fixtures shall be located such that current and future tree canopies do not interfere with the distribution of the light.
- The use of street light fixtures mounted over the travelled portion of the road is encouraged to avoid trees and to achieve improved streetlight spacing.
- A disconnect is to be installed next to the first street light pole on the circuit. The orientation will be to install the pedestal as close as possible to the street light pole between the sidewalk and the pole or between the pole and the property line frontage if there is no sidewalk, with the access door facing the street for oncoming traffic.
- This pedestal orientation will affect the orientation of the street light pole installation. The street light pole will now need to be installed so that the access cover of the pole is positioned so that the contractor can remove the cover and view the oncoming near side traffic.
- The maximum number of lights that can be attached to a single circuit is 10 unless voltage drop calculations are provided that demonstrate the circuit can accommodate the load.
- The conductors from the transformer to the disconnect shall be installed in a 50 mm PVC duct.
- Street light poles on local and collector roads with residential dwelling units to utilize a maximum mounting height of 4.5m.
- Existing streetlights shall be shown as faded open circles and labelled elevation.
- The streetlight cable shall be indicated by a black line with an SL imposed on the line.
- Designers should be aware of driveway locations and living room windows when determining the location of lights.
- The design is to be drawn at a 1:500 scale.
- Final designs must be accepted by the Municipality.

#### **9.9.4 Roundabout Lighting**

The lighting requirements for roundabouts shall be supported by detailed photometrics that meet the latest version of the RP-8 standard and the Transportation Association of Canada's Guide for the Design of Roadway Lighting. Center lighting shall be avoided as this is difficult to maintain and may not provide adequate lighting in the roundabout.

### **9.9.5 Walkway Lighting Design**

Walkway lighting designs shall be comprised of the following:

- 26 W Eaton AVS or 35 W Lithonia KAD LED fixtures.
- 4.6 m pole (black powder coated galvanized square tapered steel or aluminum).
- The first light from the street shall be 15m from the sidewalk or 15m from the edge of pavement if no sidewalk is present.
- Spacing of the light along the walkway shall be approximately every 30m, noting most walkways require only one additional light usually located at the rear of the residential property line; severe bends or stairs may require tighter spacing.
- Walkway lights are to intersect street circuits at a junction box located at one end of the walkway.
- Streetlight wire shall be placed in a 50 mm PVC duct.
- Bollards located at either end of a lit walkway must be removable for maintenance purposes.

### **9.9.6 Residential Street Light Installation & Inspection Guidelines**

The same light standard must be used from one end of a street to the other regardless of how many phases of construction are involved. A power disconnect must be installed at the transformer. All installations must be inspected by the Electrical Safety Association (ESA). The Contractor is responsible for arranging inspection with ESA.

## **9.10 UTILITIES**

### **9.10.1 Telecommunications**

Telephone, cable, and fibre optic services shall be underground in locations as shown on the typical road cross-sections and shall be installed by an approved utility Contractor.

### **9.10.2 Hydro**

Hydro service shall be underground in locations as shown on the typical road cross-sections and shall be installed by Hydro or an approved Contractor.

### **9.10.3 Gas**

Gas service shall be underground in locations as shown on the typical road cross-sections and shall be installed by the Gas Company or an approved Contractor.

## **9.11 ROADWAY SURFACE MAINTENANCE AND REHABILITATION**

For the surface maintenance and rehabilitation of rural roadways, and only where approved by the Municipality single or double surface treatment as well as cold in-place recycling with expanded asphalt may be permitted. Surface treatment is to be completed in accordance with OPSS.MUNI 304 and OPSS.MUNI 1103. Cold in-place recycling with expanded asphalt is to be completed in accordance with OPSS.MUNI 335. At the discretion of the Municipality, surface cracking of an asphalt roadway may be temporarily sealed through traditional rout and seal methods. Other methods may be recommended by a Geotechnical Engineer.

Crossings made on an existing roadway, when approved shall be reinstated with unshrinkable fill up to sub-grade followed by pavement matching the existing adjacent pavement structure. The existing asphalt shall be milled to allow the new asphalt to be lapped at least 0.3 m with a tack coat. Where unshrinkable fill is not used and the backfill materials vary greatly from the existing subgrade soils, frost tapers shall be employed as directed by the Geotechnical Engineer.

## 10.0 TREE PLANTING

### 10.1 PLANT SUBMISSION REQUIREMENTS

All developers will provide planting plans prepared and stamped by an Ontario Registered Professional Forester or a certified member of the Ontario Association of Landscape Architects. The planting plan must be included on a standard plan of subdivision drawing or a grading plan which illustrates lots dimensions (particularly frontages), as prepared by the consulting engineer. The plans will then be submitted to the municipality's plan reviewer for review, comment and final acceptance.

As with any Landscape Plan submission refer to by-law 84-2002, the following components must be included on the planting plan submission:

1. North Arrow and appropriate scale.
2. Title Block including: drawing title, drawing number, key map, address of property, draft plan number, application number.
3. Signed and Stamped by a Professional Landscape Architect or an Ontario Registered Professional Forester who is certified and licensed in the Province of Ontario.
4. Property lines, adjacent streets, adjacent land uses, driveways, sidewalks and parking.
5. Location of easements, daylight triangles, 0.3m reserves, land dedications.
6. All utilities and services (i.e., fire hydrants, streetlights, telephone poles, transformer vaults, guy wires, above ground service boxes, bell, cable tv, gas, hydro, sewer and watermain easements etc.).
7. Any existing vegetation to remain.
8. Design and location of streetscape elements (street trees should be shown at 75% of the mature canopy size).
9. A detailed plant list showing key, numbers of plants, botanical and common names and plant size at installation date.
10. Dimensions between trees and hydro facilities. Note that setback dimensions have been outlined below to ensure long-term conflicts are minimized.

### 10.2 STREET TREE PLANTING DESIGN OBJECTIVES

When designing appropriate street tree planting plans, designers shall consider site location, the physical and biological requirements of each tree, species diversity and the elements of design. Street trees are to

be located on the public right-of-way and adhere to the design objectives, spacing and locations requirements of this document.

- One tree shall be planted for each residential lot at a maximum interval of 15.0 m on centre spacing.
- The planting plan should accommodate a tree planting scheme which is mirrored on both the sides of the street. A maximum of 4 of any one species or variety is to be shown on one side of the street in a row. To provide a 'closed canopy effect', trees with a similar shape or form (e.g. vase, upright, oval) are to be selected and grouped.
- To ensure the health and vitality of street trees, ensure that sufficient soil volume and areas are provided. Quality soils capable of supporting tree growth should be used in all cases.
- Select plant material that is suitable for the space and context. As large canopied trees provide greater public benefit, these trees should be chosen over medium and small canopied trees assuming no conflicts exist.
- In cases of subdivision phasing, the planting plan should reflect the character of adjacent phases.
- User safety should be deemed a priority and ensure that visibility and accessibility are achieved.

### **10.2.1 Street Tree Spacing and Location Requirements**

These specifications are to serve as a standard for the planting of all Street Trees. All tree planting in the public right of way will be submitted for and landscape plans are to be accepted by the municipality's plan reviewer prior to installation.

- One tree shall be planted for each residential lot at a maximum interval of 15.0 m on centre spacing. Since large trees provide the most benefits, the largest tree that fits the space should be considered. Minimum tree spacing should be determined by mature canopy size.
- Trees should not be planted in areas where there is inadequate space for healthy root growth. Trees should not be planted in spaces with less than 1.5 metre width, such as planting areas defined by two curbs, curb and fence, or sidewalk and fence.
- Trees should be centered in the boulevard planting strip, unless conflict with utilities exists. Where the sidewalk is curb-faced and no boulevard exists, the trees shall be planted 1.0 metre behind the sidewalk and no more than 2.0 metres behind the sidewalk within the public right of way.
- At roadway intersections or vehicular access points, street trees shall not be planted within the 18.0 metre sight triangle along the boundary of the intersecting roadway - measured from the point of intersecting curb lines, except where engineering standards indicate otherwise.

- Trees should be planted along the flankage of all lots outside the sight triangle using the same spacing interval required for frontages. A minimum of two trees should be planted at each corner lot, unless conflict with site features exists.

### 10.2.2 Lot Width Considerations

Where the lot width is less than or equal to 9m (30 ft), plant one tree per lot selecting an ornamental or medium sized tree, depending on special constraints. Where lot width is between 9m (30ft) and 15m (50ft), plant one tree per lot selecting a large shade tree species. Where lot width is 15m (50 ft) or larger, plant one tree per lot selecting a large shade tree. All tree species to be compliant with from By-Law No. 84-2002 Appendix 5. Refer to table below for summary.

		Lot Width (m)		
		< 9.0	9.0 – 15.0	>15.0
Boulevard Width (m)	> 2.0	Small Shade	Large Shade	Large Shade
	1.2 – 2.0	Ornamental or Medium Shade	Small Shade	Small Shade
	< 1.2	No Tree	No Tree	No Tree
No Sidewalk		Ornamental or Small Shade	Large Shade	Large Shade
Overhead Hydro Present		Ornamental	Ornamental	Ornamental

### 10.2.3 Site Requirements

- Trees will not be planted in a direct line with a drainage swale between lots
- The minimum distance from the centre of a tree to the following infrastructure is:
  - Street Light Pole – no closer than 6.0 m. (20 ft) (anticipated mature canopy)
  - Fire Hydrant– no closer than 6.0 m. (20 ft)
  - Stop Sign or Traffic Signal – no closer than 15.0 m. (50 ft) and in accordance with sight triangle and mature canopy size
  - Hydro Pole - no closer than 3.0 m. (10 ft) (anticipated mature canopy)
  - Driveway, Lead Sidewalk going into a property – no closer than 2.0 m. (6 ft)
  - Hydro Transformer - no closer than 2.0 m. (6 ft)
  - Watermain – - no closer than 2.0 m. (6 ft)
  - Gas Main - no closer than 2.0 m. (6 ft)
  - Underground Services - no closer than 2.0 m. (6 ft)
  - Property Boundary - no closer than 1.0 m. (3 ft) (ownership conflicts)

- Utility and Telecom. Trench- - no closer than 1.0 m. (3 ft)
- Beneath high voltage overhead utility wires, only ornamental tree varieties shall be planted. Large and medium shade trees are suitable near single phase, street light cable and homeowner service cables. The tree leader shall not be located directly beneath such wires.
- For cul-de-sac island and roundabout surfaces, trees and all any other landscape features are required on the planting plan. The planting of all trees, shrubs and perennials and installation of any other streetscape feature should take place simultaneously. If some planting is required before the majority (i.e. for model homes) the developer shall be in contact with Municipality staff to discuss alternative arrangements prior to installation.

### **10.3 PLANTING STANDARDS AND SPECIFICATIONS**

- Refer to Figure D-6 Landscape Details Tree Planting.
- Plant material shall conform to the most recent version of Canadian Standards for Nursery Stock. Plant material shall be of standard quality, true to name and type, and first class representative of their species or variety.
- Plant material shall be nursery grown for at least two years under climatic conditions similar to the planting region. Proposed sources of nursery stock and origin of seed or cuttings used should be available upon request.
- Stock Type:
  - Street Tree Planting should be balled & burlapped, bare root or container grown and shall only be pruned to promote strong branching i.e. remove dead or poorly structured branches. Trees with multiple leaders, unless specified, will not be accepted nor will trees that have been clipped back or topped.
  - Root balls of balled and burlapped trees shall be wrapped with non-synthetic, untreated, biodegradable burlap around a solid standard sized ball and secured with similar rope or twine.
  - Root ball of container grown trees should be well established with a root system that has developed sufficiently to retain its shape when removed from the container. Plants shall not be pot bound, nor have kinked, circular or bent roots.
  - Root ball of bare root trees shall be healthy and well branched. Bare root trees should be dug and planted when dormant and the ground is not frozen.
- The minimum size of trees at time of planting shall have a caliper of 50 mm DBH (diameter at breast height). Larger sizes may be required to provide a landscape effect. In addition, the tree shall be clear of branches to 1.5 metres and have a minimum of 6 scaffold branches.

## **10.4 GUARANTEE AND REPLACEMENT**

All plant material is required to be guaranteed for two (2) growing seasons from the date of provisional acceptance. The guarantee does not include vandalism, storm storage damage, animal damage or mechanical damage unrelated to the contractor's activities. All replacements shall be of the same kind and size as specified in the plant list. Replacement costs shall be borne by the party responsible for planting the tree (the name on the planting permit). After two growing seasons the plant material will be required to show active growth. Merely surviving will not be acceptable; a minimum of two inches of annual twig extension will be required.

## 11.0 GRADING

### 11.1 GENERAL

The grading and drainage design, whether it is being prepared for an individual lot, small site, or entire development, shall be completed with the following objectives:

- a) to provide positive drainage and maximize the use of land while minimizing maintenance requirements.
- b) to complement the land and suit the type of structure that is to be constructed.
- c) to accommodate runoff from adjacent lands and to ensure that the adjacent and downstream properties are not adversely affected.
- d) to minimize the perimeter disturbance and preserve existing trees, where required.
- e) to minimize the use of rear lot catch basins and retaining walls.

Where the overall grading of an area, such as a park or townhouse block, cannot be completed until after the area is fully developed, for example in the case of a phased development, the designer will be required to develop an interim grading and drainage design for that area, to the satisfaction of the Municipality.

### 11.2 GRADING REQUIREMENTS FOR VARIOUS SITUATIONS

Grading for a plan of subdivision, site plan (guidelines where applicable) and infill lots is to be designed by a Professional Engineer and certified by a designated professional as per the requirements of the implementing Agreement and is to be completed in accordance with the following standards:

#### 11.2.1 Subdivisions

Developments created by a draft plan of subdivision shall conform to the following lot grading standards and will not adversely affect the abutting or adjacent properties.

#### 11.2.2 Site Plans

Developments subject to site plan approval are to be graded and drained internally. Grading and drainage are not to adversely affect adjacent properties. The site's grading and drainage shall conform to the overall drainage pattern of the adjacent lands as certified by the design engineer at the time of the permit for each building.

### **11.2.3 Severances, Lifting of Part Lot Control & Infill Lots**

Developments created by severance, lifting of Part Lot Control and infill lots shall conform to the lot grading standards in a plan of subdivision and are not to adversely affect the abutting and/or adjacent properties.

### **11.2.4 Blocks**

Development on blocks within registered plans of subdivision are subject to site plan approval (as above). Drainage and grading of such blocks shall conform to the accepted overall subdivision design and shall be certified by the site design engineer.

### **11.2.5 Capital Projects**

When grading is required on municipal capital projects, the designer shall determine match points that appear to naturally blend proposed design grades with existing topography. Consideration shall be given to transitions with intersecting streets, driveway profiles, drainage, utilities, existing retaining walls, potential impacts on trees and other landscaping features. Wherever possible, the designer shall take every opportunity to eliminate or reduce the size of existing retaining walls owned and maintained by the Municipality. Consideration is to be given to maintenance and aesthetics of grassed areas such as lawns and boulevard areas.

Grades shall not be altered around trees on the basis of 30 cm of distance from the stem for each 3 cm of trunk diameter at breast height 1.5 m above ground. While a 4:1 slope or greater is desirable from a maintenance perspective, a maximum 3:1 slope is acceptable. Proposed driveway grades are not to exceed 10%.

### **11.2.6 Parks and Open Space**

Overall grading of Park and Open Space Blocks within new plans of subdivision shall conform to the master grading plan for the subdivision and must accommodate overland flow routes, etc. Detailed grading within Parks and Open Space areas will be subject to review by the Thames Centre Community Services and Facilities Department.

### **11.2.7 Variations / Modifications**

There will be site specific situations where all the criteria may not apply. Proposed grading that does not conform to the appropriate grading requirements standards will be reviewed taking into account the mitigating circumstances that require the proposed variations or modifications and is subject to the approval of the Municipality.

## 11.3 MAJOR/MINOR STORM DESIGN

As storm sewer systems (referred to as the minor system) are designed to accommodate storm runoff from a 2 year storm event, the lot grading design (referred to as the major storm system), must be designed to accommodate runoff from storm events that exceed the design capacity of the storm sewer system. These allowances, in the form of major overland flow routes, shall provide for the effective routing of major overland storm flow from residential areas to an acceptable overland flow outlet location. It is the designer's responsibility to complete hydraulic modelling to ensure that appropriate conveyance capacity exists within all overland flow routes.

When designing overland flow routes the following criteria shall apply:

- Preference is for major overland flows to be routed within road allowances.
- The conveyance of major overland flows up to the 100 year storm event shall be contained within the municipal right-of-way or dedicated easement(s). The hydraulic calculations shall demonstrate that the 250 year flows can be safely conveyed but flows up between the 100 and 250 year events may be conveyed outside of the road allowance or easement. In addition to the above, the adequate conveyance capacity of major overland flow routes must be demonstrated for the proposed design of raised intersections and/or raised crosswalks.
- The maximum allowable ponding at gutters on roads is 300 mm; the maximum allowable ponding within rear yard swales at catch basins and within open space areas is 450 mm.
- Building opening elevations adjacent to overland flow routes on roadways shall be at least 300 mm above the maximum surface water elevation for the major design storm.
- Accommodate overland flow routes into a stormwater management pond (if applicable).
- Both existing and proposed overland flow routes are to be identified with directional arrows on all grading drawings.

## 11.4 GRADING REQUIREMENTS ALONG PROPOSED/EXISTING ROADS

The grading along the development property limits adjacent to existing or proposed municipal roads is to be graded to blend in with the future road grades. Where future grades have not yet been established and approved by the Municipality, the developer is to retain the services of a Professional Engineer to obtain and or develop the necessary information to establish the future centre-line road profile and property line grades and have such approved by the Director of Public Works.

## 11.5 GRADING STANDARDS

The following standards are to be considered when designing lot and adjacent boulevard grading:

### 11.5.1 Drainage

- The boulevard and a minimum 6.0m at the front of any residential lot must drain towards the abutting road.
- The location and direction of drainage along the rear and side lot lines is to be shown on the grading drawings. One drainage direction arrow for each change in grade for all lots is to be provided.
- The drainage from single-unit lots in the same subdivision may be drained between other single-unit lots (i.e., back to front drainage).
- The drainage from impervious areas on lots in a new subdivision is not to flow across existing lots abutting the new subdivision.
- The drainage from single-unit and semi-detached lots is not to drain onto Multi-unit, Commercial or Institutional blocks (with the exception of the overland flow routes).
- All multi-unit, commercial and institutional block drainage is to be self-contained.
- Where a new subdivision abuts an existing development or undeveloped land, the existing ground elevations at the common property line are to remain unchanged and existing drainage of abutting lands is not to be disturbed, or obstructed, unless written permission is granted by the affected land owner.
- Localized surface drainage from abutting properties, to be developed in future, may be discharged onto the proposed lots in a subdivision.
- Identify existing vegetation and set grades to retain where possible.

### 11.5.2 Elevations

- Show existing elevations by contours. Contours are to extend a minimum of 30 m beyond the limit of the site plan, or subdivision.
- Show existing spot elevations at all lot/block corners along the boundary of the development, and along all major overland flow routes.
- Show existing centre-line of road elevations every 20m for existing, abutting and connecting streets.
- Show existing spot elevations around existing house/units and at house/unit openings for new proposed major overland flow routes through existing developments.
- Show proposed elevations on ALL corners of the proposed lots.

- Show finished ground elevations around house/unit.
- Show final centre-line road elevations, every 20 m as well as at break points and high and low points in the road profile. Identify (label) the break points, high/low points.
- Show proposed elevations at all high points or break points where the direction of drainage along rear and side lot lines changes.
- Show proposed bottom of swale elevations at pertinent intervals, and at property lines.
- Show proposed elevations at the top and bottom of all steep slopes (3H: 1V, max.).
- Show proposed top and bottom retaining wall elevations.
- Show proposed top and bottom noise barrier wall elevations.

### 11.5.3 Slopes

- Yard surfaces shall have a minimum slope of 2%.
- Front yard surfaces shall have a maximum slope of 10%.
- Rear yard/side yard (walkouts/back splits) surfaces including swale cross-falls shall have a maximum slope of 3H: 1V.
- Berms shall have a maximum slope of 3H: 1V.
- Road and boulevard surfaces shall have a minimum cross-fall grade of 2% and a maximum cross-fall grade of 4% in new subdivisions.
- Driveway surfaces shall have a minimum grade of 2% and a maximum grade of 10%.
- Specify stepped foundations, side to side for lots fronting streets with a road grade of more than 3%.

### 11.5.4 Swales

- Drainage flows which are carried around houses are to be confined in defined swales, located as far from the house as possible.
- Minimum swale grade is 2%.
- Maximum of 16 lots draining to a rear yard swale, out-letting to a rear yard catch basin.
- Maximum length of swales permitted is 76m, out-letting to a rear yard catch basin.
- The maximum flow allowable in a side yard swale or a swale discharging across a boulevard onto a Municipal Right-of-Way shall be that from 4 rear yards.

- The side yard swale is to be a minimum of 150 mm lower than the finished ground elevation at the house.
- The average rear yard swale depth is 225 mm. The minimum swale depth allowed is 150 mm.
- The maximum swale depth is variable but is dependent on location and safety considerations.
- Show the location and direction of flow in swales by means of arrows. Show at least one arrow at the rear of each lot.

### 11.5.5 Catch Basins

- The maximum length of swales permitted to drain to a catch basin is 76 m.
- A maximum of 16 lots draining to a rear yard catch basin is allowed.
- Front yard catch basins are not permitted, except in unusual circumstances where a rear-yard catch basin cannot be provided.
- No surface ponding is allowed during a 2 year design storm event.
- Under a 100 year design storm event, 300 mm surface ponding is allowed at catch basins on roads, and 450 mm surface ponding is allowed at rear yard catch basins.
- Flat see-saw profiles (identical high and low points) will not be allowed in either road profile designs or rear yard swale designs. See-saw profiles must slope in a cascade that allows major storm flows (Overland Flows) to drain along the road or lots to an acceptable Overland Flow Outlet.
- In reconstruction projects within existing developed areas of the Municipality, where the existing profile and driveway conditions cannot accommodate a cascading see-saw profile, the proposed profile must provide for adequate road drainage and be acceptable to the Director of Public Works.

## 11.6 ADDITIONAL INFORMATION TO BE SHOWN ON PLAN

Grading Plans shall be designed in accordance with the standards listed above and will contain the following information where applicable.

Required Information	Information – Where Applicable
<ul style="list-style-type: none"> <li>• Standard Thames Centre Title Block</li> <li>• North Arrow</li> <li>• P. Eng. Stamp</li> </ul>	<ul style="list-style-type: none"> <li>• Sidewalk Ramps</li> <li>• Sewer Easements and Widths</li> <li>• Building Setbacks for Rear Yard Catch</li> </ul>

<ul style="list-style-type: none"> <li>• Street Names</li> <li>• Lot and Block Frontages</li> <li>• Lot and Block Numbers</li> <li>• 0.3 m Reserves</li> <li>• Existing Features (trees, fences, houses, etc.)</li> <li>• Sediment and Erosion Control Measures</li> <li>• Delineation of Proposed Unit/house</li> <li>• Maintenance Holes and Fire Hydrants</li> <li>• Catch Basins</li> </ul>	<ul style="list-style-type: none"> <li>• Basin Leads</li> <li>• Steep Slope Lines (3:1 desirable)</li> <li>• Sidewalks to be Constructed</li> <li>• Headwalls (inlets/outlets)</li> <li>• Channels</li> <li>• Pedestrian Walkways (fencing, posts, width, and driveways)</li> <li>• Noise Barrier Walls and Details</li> <li>• Swales percentage of slopes and extension of outlets</li> <li>• Culvert sizing diameter and inverts where applicable</li> </ul>
---	--

## 11.7 GRADING NOTES

The following notes are to be included on the Grading Drawings:

- Existing drainage of abutting lands is not to be disturbed.
- Localized surface drainage from abutting properties to be developed in future may be discharged onto the proposed lots in this subdivision.
- Basement openings to be minimum 300 mm above the centre-line of road unless otherwise approved by the Director of Public Works.
- Ground elevations at houses abutting overland flow routes are to be 225 mm above overland flow route spill point elevation.
- Retaining walls, 1.0 m high or greater, are to be designed by and constructed to the specifications of a registered professional engineer in accordance with the Ontario Building Code.
- For Subdivisions: Sump pump discharge must be directed to the storm sewer via the storm PDC.
- Where there are no storm PDCs, sump pump discharge must be directed away from driveways and sidewalks and must not extend beyond property limits.

## 12.0 EROSION AND SEDIMENT CONTROL

### 12.1 GENERAL

Construction sites, by their nature, result in the disturbance of the onsite natural materials, as well as impacting on the surrounding areas. Sediment and erosion control measures are to be used on ALL construction sites to limit the effects of the proposed construction on the surrounding areas and infrastructure. The extent and durability of the required measures is determined by the sensitivity of the area that is to be protected.

### 12.2 REFERENCE

The following guidelines shall apply in conjunction with the Ministry of Natural Resources and Forestry Guidelines on Erosion and Sediment Control for Urban Construction Sites.

### 12.3 GENERAL INFORMATION REQUIREMENTS

Sediment and erosion control measures are to be identified on all lot grading plans, stormwater management ponds, channels, plan & profile drawings and on detail drawings. Where extensive measures are required because of the sensitivity of the surrounding area, or the scale of the drawing is such that the measures are not clear, then the sediment and erosion control measures are to be identified on a separate plan.

### 12.4 CONSERVATION AUTHORITIES

Approvals are to be obtained from the applicable Conservation Authority for works which are in or adjacent to floodlines, fill lines and hazardous slopes, prior to the construction of services and final approval of the engineering plan.

### 12.5 PARKS AND OPEN SPACES

Approvals are to be obtained from the Planning Division for sediment and erosion control measures adjacent to any open space areas – flood plain, environmentally significant areas, natural areas, ravines, parks, etc., prior to any site alteration, construction of services or final approval of engineering plans.

### 12.6 TYPICAL APPLICATIONS

	Application	Description
1	Silt Fence	Silt Fences are to be constructed with an approved geotextile fabric along rear/side lot lines and top/bottom of steep slopes.
2	Straw Bale Filters	Straw Bale Filters are to be constructed around drain inlets/outlets for temporary short-term control measures.

	<b>Application</b>	<b>Description</b>
<b>3</b>	Rock Check Dam	Rock Check Dams are to be constructed in conjunction with an approved geotextile barrier within open drainage systems.
<b>4</b>	Straw Bale Check Dam	Straw Bale Check Dams are to be constructed across low flow swales or ditches.
<b>5</b>	Rip Rap	Rip Rap is to be constructed with an appropriate geotextile barrier within inlet/outlet structures, overflow protection, channel banks, gabions and rockfill structures.
<b>6</b>	Rock Protection	Rock Protection is to be constructed in conjunction with an approved geotextile barrier within inlet/outlet structures, overflow protection, channels banks, gabions and rockfill structures.

## 12.7 SPECIFICATIONS

### 12.7.1 Rip Rap

Rip Rap is to be graded in sizes ranging from 100 mm to 200 mm, as per Ontario Provincial Standard Specification (OPSS)-1004.05.06.01 (concrete rubble is not acceptable).

### 12.7.2 Rock Protection

Rock Protection is to be graded in sizes ranging from 100 mm to 500 mm, as per Ontario Provincial Standard Specification (OPSS)-1004.05.06.02 (concrete rubble is not acceptable).

<b>Types of Application</b>	<b>Required Geotextile Functions</b>	<b>Recommended Geotextile</b>	<b>Properties and Characteristics</b>
Subdrains French Drains Foundation Drains Trench Drains Blanket Drains	Filtration Drainage	200R 240R 270R	Good lateral drainage Suitable for wide spectrum of soil permeabilities
		300R 360R	Used in weaker soil conditions Used in conjunction with coarser drainage materials
Gabion Lining Retaining Walls Drop Structures Ditch Lining	Filtration Drainage	200R 240R 270R	High Permeability Medium tensile strength at high elongation Good filtration
		360R	Medium puncture resistance Good lateral drainage Withstands more severe hydraulic conditions
Revetments Channel Linings Rivers/Creeks Rivers/Creeks	Filtration Drainage Reinforcement	270R	300 mm maximum rip rap size not to be used under severe hydraulic conditions.
		400R	Medium tensile strength at low elongation woven scrim reinforcement 600 mm maximum rip rap size

Types of Application	Required Geotextile Functions	Recommended Geotextile	Properties and Characteristics
		360R	450 mm maximum rip rap size medium tensile strength at high elongation
		270R	Under sub-ballast in drainage ditches
		1000R 1200R	Highest strength non-woven geotextile manufactured recommended use with armour stone in excess of 2.72 tonnes highest level filtration
<b>NOTE:</b> All of the above information was taken from Terrafix Geosynthetics Inc.			

## 12.8 SEDIMENT CONTROL MEASURE NOTES

The following sediment control measure notes are to be shown on the construction drawings, either on the plan that details the sediment and erosion control measures, or on the notes and details drawing. Please note that the following sediment control measure notes are examples only and may vary to suit the individual project.

- Protect all exposed surfaces and control all runoff during construction.
- All erosion control measures are to be in place before starting construction and remain in place until restoration is complete.
- Maintain erosion control measures during construction.
- All collected sediment must be disposed of at an approved location.
- Minimize area disturbed during construction.
- All dewatering must be disposed of in an approved sedimentation basin.
- Protect all catch basins, maintenance holes and pipe ends from sediment intrusion with geotextile (Terrafix 270R).
- Keep all sumps clean during construction.
- Prevent wind-blown dust.
- Straw bales are to be used in localized areas as shown and as directed by the engineer during construction for works which are in or adjacent to floodlines, fill lines and hazardous slopes.
- Straw bales to be terminated by rounding bales to contain and filter runoff.
- Obtain approval from applicable Conservation Authority prior to construction for works which are in, or adjacent to floodlines, fill lines and hazardous slopes.

- All silt fencing and details are at the minimum to be constructed in accordance with the Ministry of Natural Resources and Forestry Guidelines on Erosion and Sediment Control for Urban Construction Sites.
- All the above notes and any sediment & erosion control measures are at the minimum to be in accordance with the Ministry of Natural Resources and Forestry Guidelines on Erosion and Sediment Control for Urban Construction Sites.

## 12.9 HYDRAULIC SEEDING

- Seed, fertilizer, and water shall be thoroughly mixed in the hydraulic seeder and mulcher into a homogeneous water slurry. When thoroughly mixed, the water slurry shall be applied to the prepared earth areas by the nozzle sprayer or extension hose.
- The Contractor shall ensure that the seeding equipment is properly calibrated to provide the proper seed coverage. The Contractor shall ensure there is a uniform dispersal of the mixed material over the entire area designated for seeding and that the spray does not dislodge soil or cause erosion.
- All cover materials shall be applied as a separate operation immediately following the application of seed and fertilizer.
- The Contractor shall ensure that the hydraulic seeder and mulcher is properly calibrated to provide the coverage as specified for each of the hydraulically applied cover materials.
- Approved Products: Flexterra HP-FGM™
- Comply with Manufacturers installation instructions and recommendations, using approved hydrospraying machines with a fan-type nozzle.
- For Erosion Control and Revegetation: To ensure proper application rates, measure and stake area. For maximum performance, apply HP-FGM™ in a two-step process:
  - Step One: Apply fertilizer with specified prescriptive agronomic formulations and 50% of seed with a small amount of HP-FGM™ for visual metering.
  - Step Two: Mix balance of seed and apply HP-FGM™ at a rate of 50 lbs per 125 gallons (23 kg/475 liters) of water over freshly seeded surfaces. Confirm loading rates with equipment manufacturer. Do not leave seeded surfaces unprotected, especially if precipitation is imminent.
- Depending upon site conditions HP-FGM™ may be applied in a one-step process where all components may be mixed together in single tank loads. Consult with Manufacturer for further details.



## **ENGINEERING DESIGN STANDARDS**

THE CORPORATION OF THE MUNICIPALITY OF THAMES CENTRE  
Erosion and Sediment Control

---

- The municipality requests that bio-diversification and natural heritage species be considered in all seeding and planting activities. This includes but is not limited to ditching, slope rehabilitation, stormwater management ponds, open space seeding, etc.

## **13.0 TRENCHLESS TECHNOLOGIES**

### **13.1 APPLICATION**

Trenchless applications allow for the installation of the infrastructure with minimal disturbance of the surface area. The Design Engineer shall be qualified to design and oversee (certify) the specific types of technology being proposed.

### **13.2 GEOTECHNICAL BASELINE REPORT (GBR)**

A Geotechnical Baseline Report (GBR) is required when a Trenchless installation is being considered. The GBR will provide detail information related to the anticipated groundwater and soils conditions, including defining and assigning the various risks and liabilities to the Owner and/or the Contractor associated with the possible changes in ground conditions that may be encountered on the proposed alignment. The Design Engineer shall provide necessary design parameters for the trenchless installation.

### **13.3 TRENCHLESS DESIGN REQUIREMENTS**

Minimum elements to be considered by the Design Engineer as part of the Trenchless Installation:

1. Pipe design (casing and/or carrier pipe as applicable)
2. Adequate room for staging areas, pipe assembly, entry and exit portals (as appropriate)
3. Blocking and grouting requirements (of carrier pipe within a casing pipe)
4. Slurry/spoil disposal
5. Erosion/Sediment Control Measures
6. Bore Geometry
7. Annular Space Plug
8. GBR Recommendations
9. Define the need for Dewatering and/or Permit to Take Water (if applicable)
10. Timing as it relates to other activities, i.e., order of operations
11. Prequalification of the contractor
12. Proximity to sewers, watermain, utilities, structures, etc.

13. Traffic Control

**13.3.1 Information to be included in Construction/Tender Drawings**

1. Pipe design (casing and/or carrier pipe)
  - a. Diameter
  - b. Alignment
  - c. Grade (plus or minus if applicable and acceptable)
2. Adequate room for staging areas, pipe assembly, design of entry and exit portals
3. Erosion/Sediment Control Measures
4. GBR Recommendations
5. Define the need for Dewatering and/or Permit to Take Water (if applicable)
6. Existing sewers, watermain, utilities, structures, etc. including elevations
7. Traffic control plans
8. Settlement monitoring / instrumentation's quantities / locations, etc.

**13.3.2 Items to be considered in the Contract Tender Documents**

1. A tender item for a 911 emergency shaft
2. A tender item for "Frac Out" mitigation measures
3. Cutter head requirements
4. Over cut dimensions
5. Swab run (depending on diameter and site specifics)
6. Bentonite lubrication
7. Machine launch & retrieval (groundwater impacts)
8. Annular space grouting
9. Settlement/heave should be monitored for frequency / duration / acceptable tolerance etc.
10. Mitigation/contingency plans
11. Damaged Pipe

12. Tracking requirements
13. Spoil/slurry disposal
14. Methods of restraint against pull-back (as applicable)
15. Complete GBR
16. Quality control (i.e. – videos, joint testing, etc. as appropriate for the technology being installed)

### **13.3.3 Record Drawing**

As part of the Record Drawing submission, at the conclusion of the project, the drawings are to be updated to show what was installed including:

1. Identify method of installation
2. Pipe design (casing and/or carrier pipe as applicable)
  - a. Material
  - b. Dimensional Ratio, include wall thickness, class, etc.
  - c. Diameter
  - d. Alignment
  - e. Grade and elevations
3. Blocking and grouting measures (as applicable)
4. Location of staging areas, entry/exit portals – in case of settlement issues. Including information with dimensions and elevations of all protection / support system, etc. not removed.

## 14.0 TRAILS AND CONNECTIVITY

### 14.1 MULTI-USE TRAILS

The Developer shall provide and construct multi-use trails in a location agreed with the Municipality during the consultation process. The design of multi-use trails shall be provided where appropriate, to provide interconnectivity within each town to encourage an active lifestyle.

#### 14.1.1 Design & Connectivity

Pedestrian access to multi-use trails shall be provided where appropriate, and looped trail concept designs are encouraged.

Multi-use trail shall be a minimum of 3.0m wide, located in a spot agreed by the Municipality and constructed as per Figure R-9 “Typical Multi-use trail”. Alternative materials for a multi-use trail must be submitted to the Municipality for approval.

In the event where a multi-use trail is located near a stormwater management facility, the trail shall loop around the entire pond. Any trail that is being incorporated around a stormwater management facility shall be implemented no less than 0.5m above a 100-year stormwater level. When trails are located around a stormwater management pond, side slopes adjacent to the trail are not to exceed 5:1 slopes.

Asphalt or concrete trails are acceptable to the municipality and are to be designed with 1% - 4% cross fall with a maximum 8% longitudinal slope. Slopes adjacent to a trail must not exceed 4:1 side slopes and a maximum elevation change from the edge of trail, to the bottom of ditch shall not exceed 0.6m.

To enhance public comfort and safety, a 3.0m buffer shall be on each side of the multi-use trail. This 3.0m buffer shall be designed in a way to maximize sightlines and provide easy maintenance along the trail. When a multi-use trail crosses a street within the Municipality, appropriate signage must be provided. In an event where barriers are required, they must not interfere with visibility or create entrapment areas.

Deciduous trees should be planted at a minimum distance of 1.8m from the edge of a trail. Maintenance is required to ensure that tree canopies are raised to a minimum of 2.4m, and shrubs must be regularly prevented from naturalizing this area. Planting of coniferous trees within this area are not permitted



## **ENGINEERING DESIGN STANDARDS**

THE CORPORATION OF THE MUNICIPALITY OF THAMES CENTRE  
Standard Drawings

---

# **APPENDIX**

## **Standard Drawings**

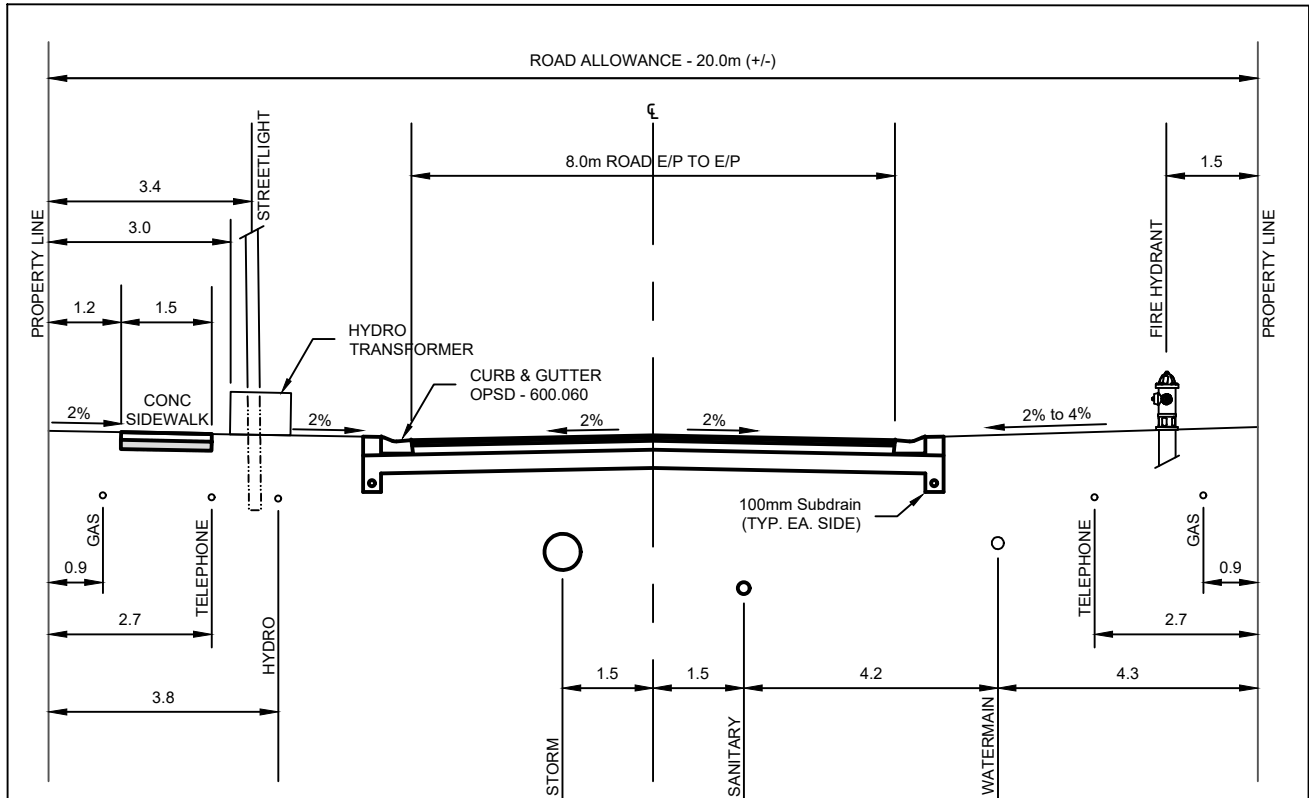

**Notes:**

1. If sidewalk is required on one side only, it shall be opposite to the watermain and light standards shall be on the same as the sidewalk.
2. the pavement structure identified are minimum requirements. Actual pavement structure to be recommended by a qualified geotechnical consultant.
3. It is preferred to place the primary hydro and transformers on the side opposite to the watermain; transformers shall be turned with the long side parallel to the R.O.W. limit
4. Gas and telephone shall be placed on both sides of the street.
5. Street lights, transformers, telephone and cable pedestals and fire hydrants shall be aligned with lot lines where possible

UTILITY	Min. Cover in Blvd	Min. Cover for Road Crossing	<b>Minimum Pavement Design</b>
Gas	0.9m	1.2m	40mm HL3
Hydro	1.0m	1.2m	50mm HL8
Comm.	1.0m	1.2m	150mm GRANULAR 'A'
Water	1.7m	1.7m	300mm GRANULAR 'B'
Storm	1.5m	1.5m	
Sanitary	2.4m	2.4m	

CORPORATION OF THE MUNICIPALITY OF THAMES CENTRE - STANDARD DRAWING

<b>Typical Cross Section</b> Urban Local Road - Cross Section	REVISION DATE:	JAN 2023
	DRAWING #:	<b>R-1</b>

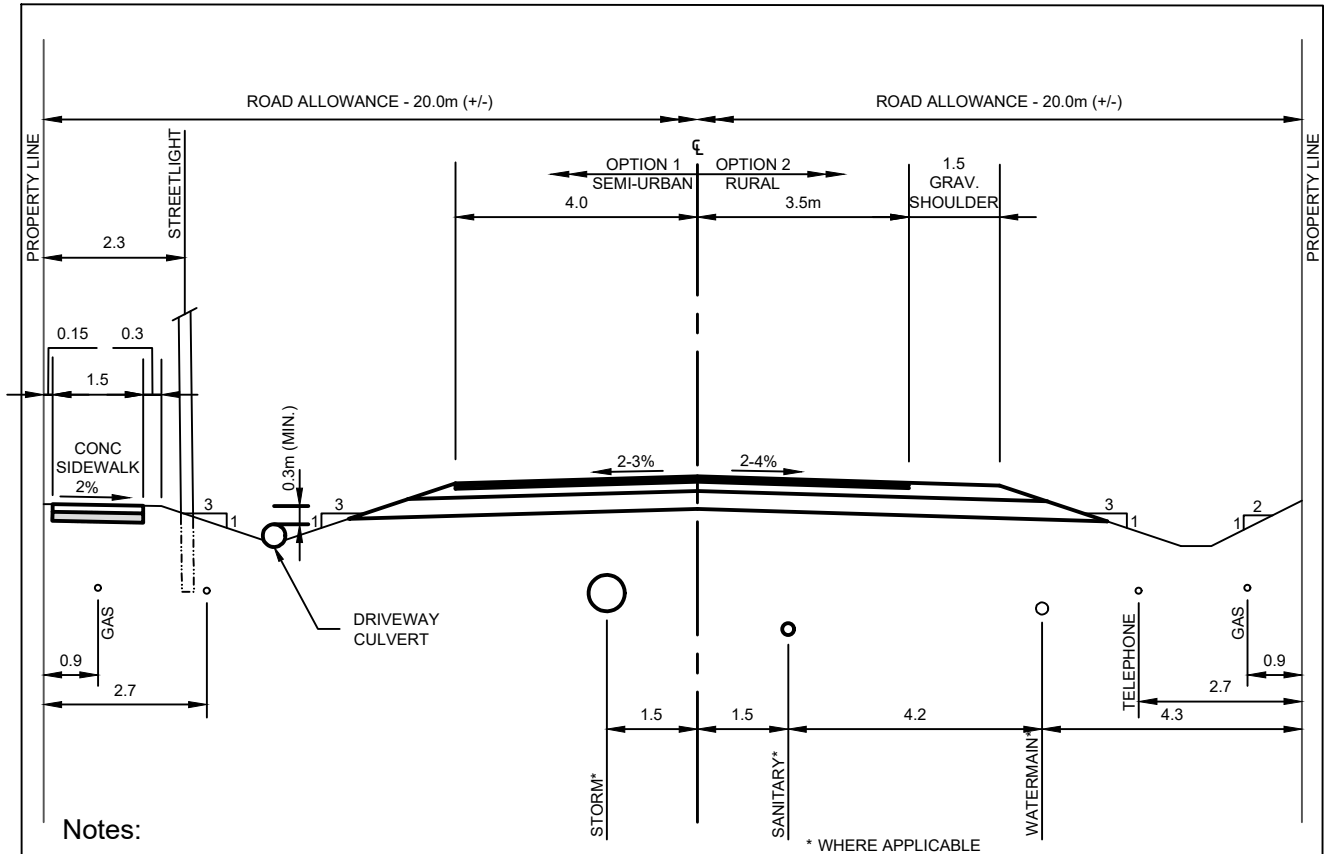

**Notes:**

1. If sidewalk is required on one side only, it shall be opposite to the watermain and light standards shall be on the same as the sidewalk.
2. Actual pavement structure to be recommended by a qualified geotechnical consultant.
3. It is preferred to place the primary hydro and transformers on the side opposite to the watermain; transformers shall be turned with the long side parallel to the R.O.W. limit
4. Gas and telephone shall be placed on both sides of the street.
5. Street lights, transformers, telephone and cable pedestals and fire hydrants shall be aligned with lot lines where possible

UTILITY	Min. Cover in Blvd	Min. Cover for Road Crossing
Gas	0.9m	1.2m
Hydro	1.0m	1.2m
Comm.	1.0m	1.2m
Water	1.7m	1.7m
Storm	1.5m	1.5m
Sanitary	2.4m	2.4m

CORPORATION OF THE MUNICIPALITY OF THAMES CENTRE - STANDARD DRAWING

**Typical Cross Section**  
Semi Urban/ Rural Road - Cross Section

REVISION DATE: JAN 2023

DRAWING #: **R-2**

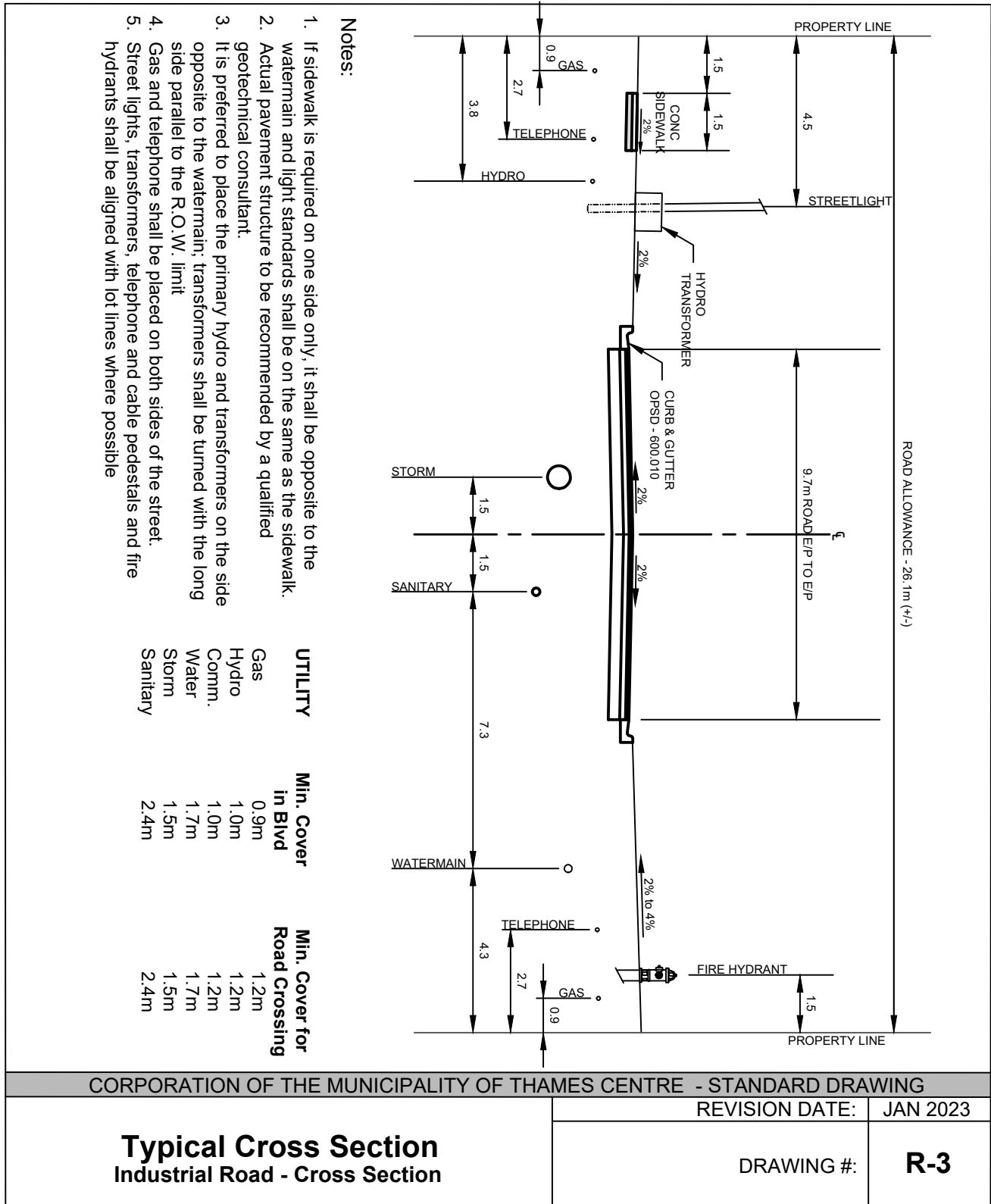

CORPORATION OF THE MUNICIPALITY OF THAMES CENTRE - STANDARD DRAWING

REVISION DATE: JAN 2023

**Typical Cross Section**  
Industrial Road - Cross Section

DRAWING #:

**R-3**

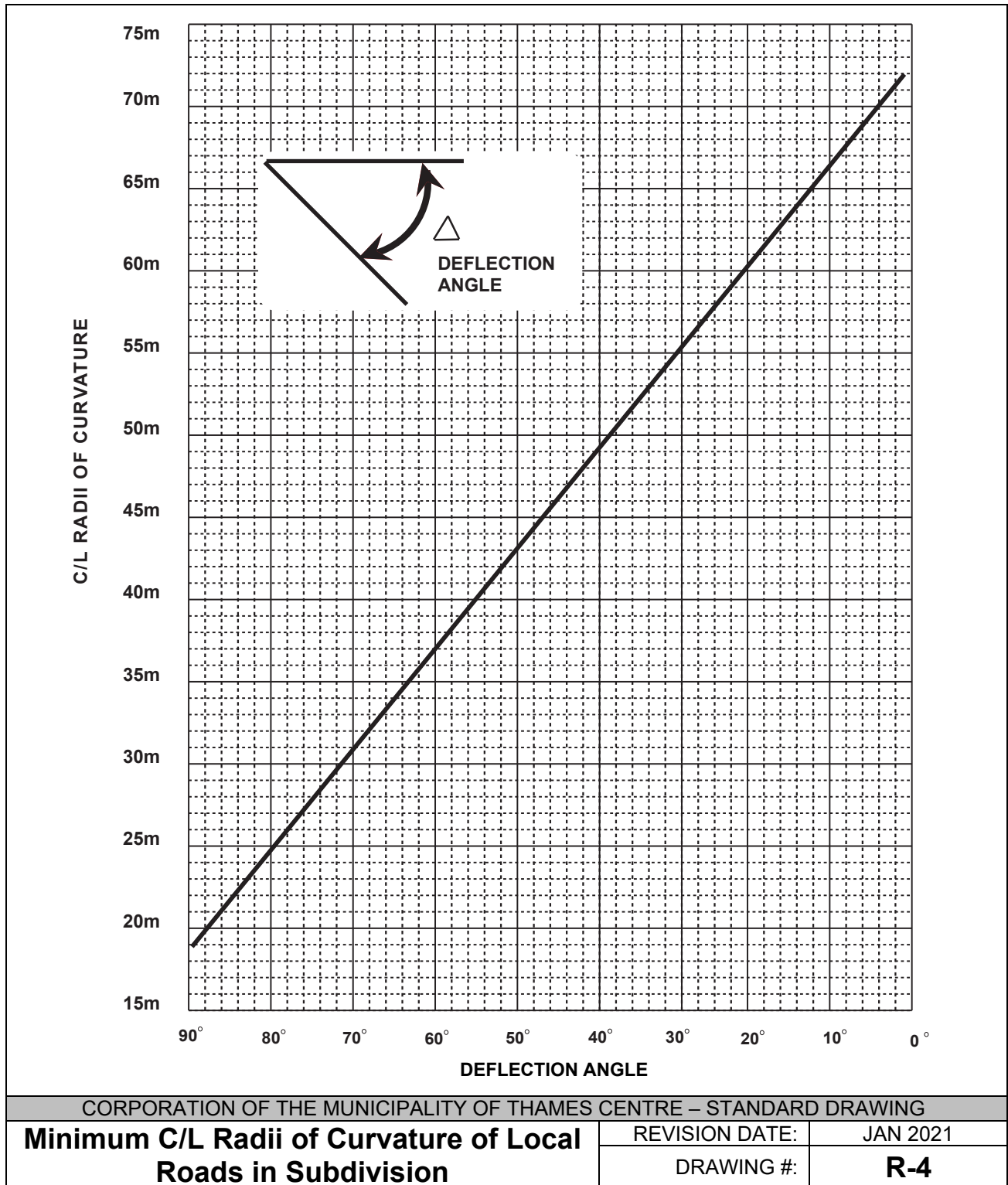

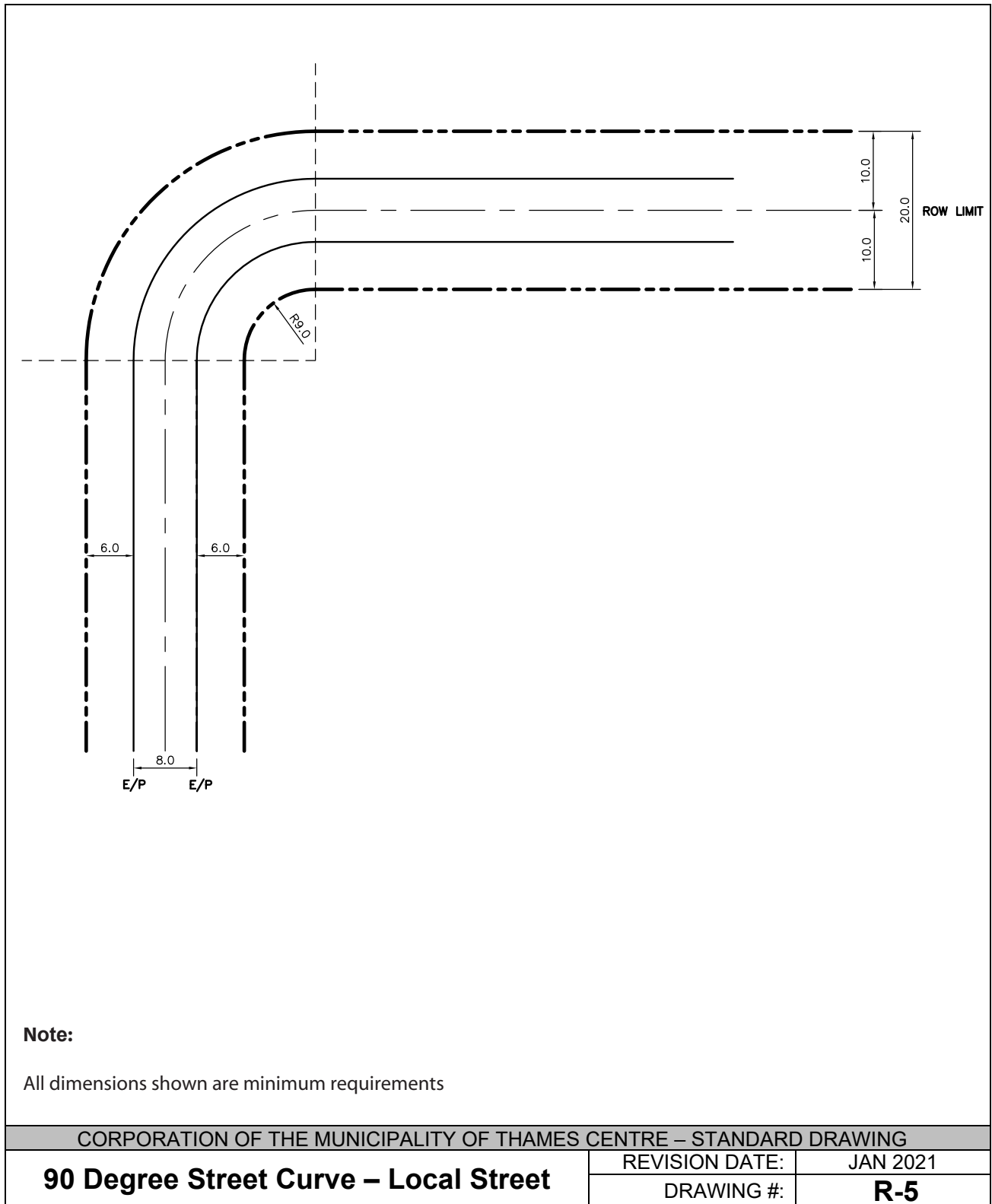

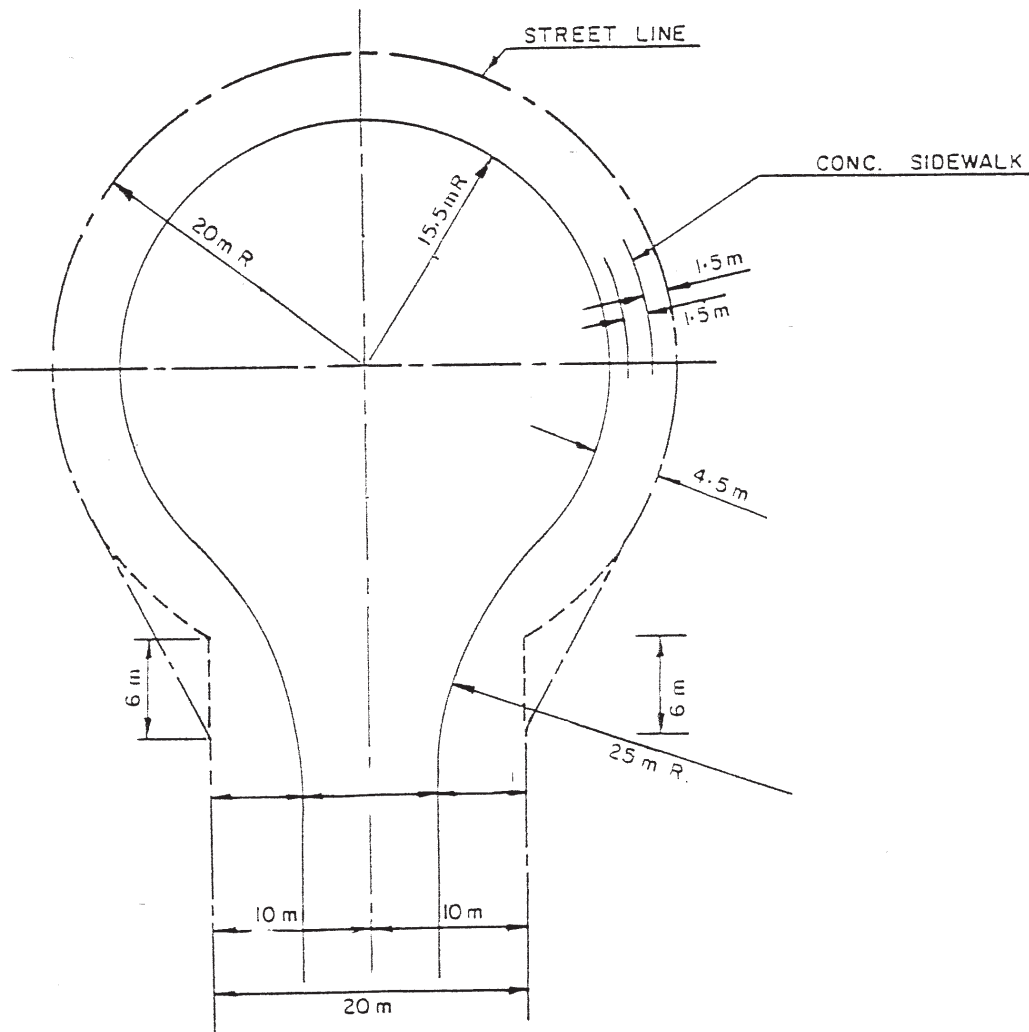

**NOTES:**

1. Grade of gutters in cul-de-sac to be 0.5% minimum.
2. Cul-de-sac alignment may be skewed subject to approval by the Municipal Engineer.
3. Road width dimensioned from edge of asphalt to edge of asphalt.
4. A curved property line with a minimum radius of 11.0 metres may be used as an alternative to the straight line transition from the cul-de-sac to standard right-of-way.
5. Road cross-fall within bulb portion of cul-de-sac to be a minimum 2% grade

CORPORATION OF THE MUNICIPALITY OF THAMES CENTRE – STANDARD DRAWING

**Standard for Circular Cul-de-Sac**

REVISION DATE: JAN 2021

DRAWING #: **R-6**

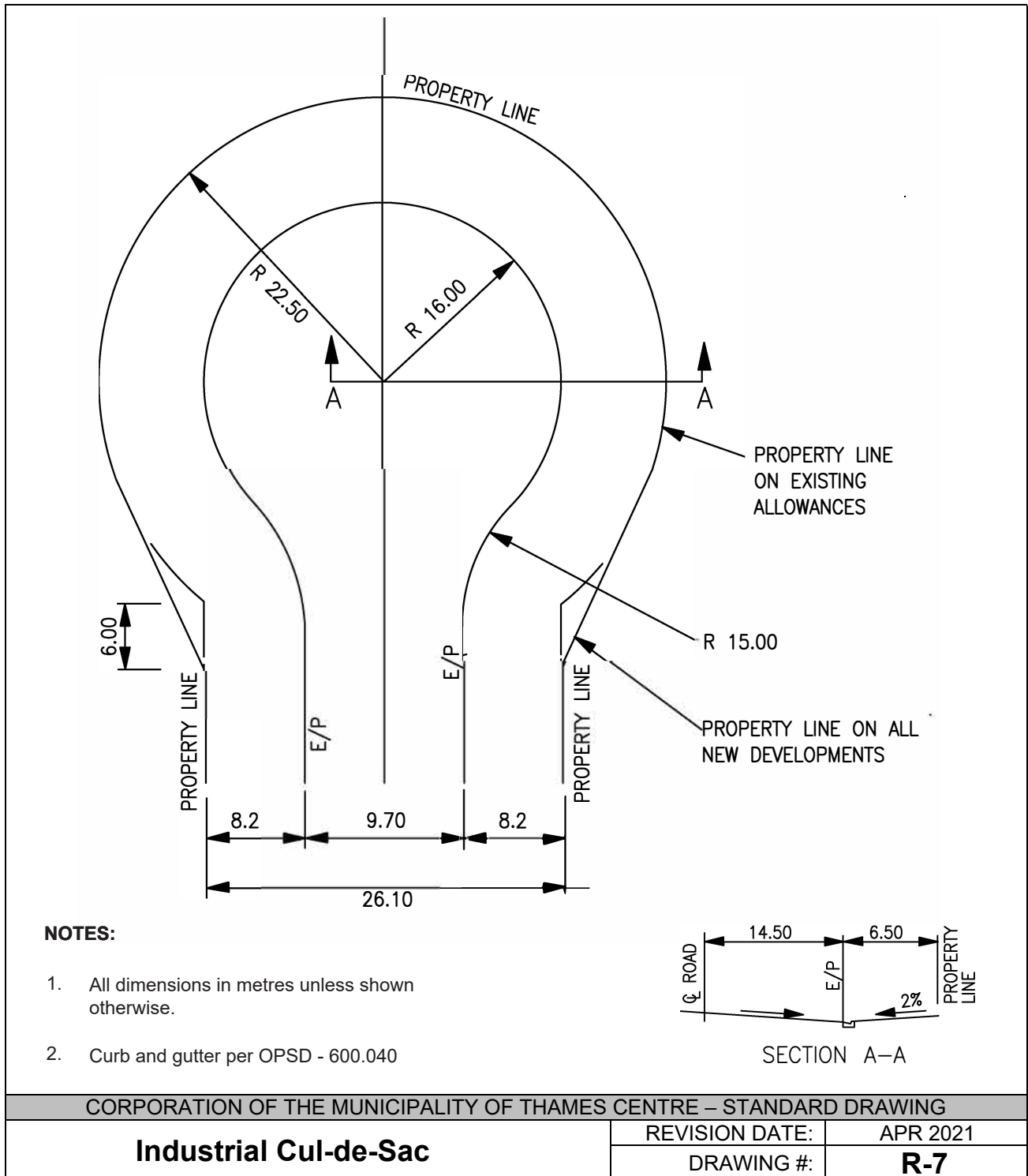

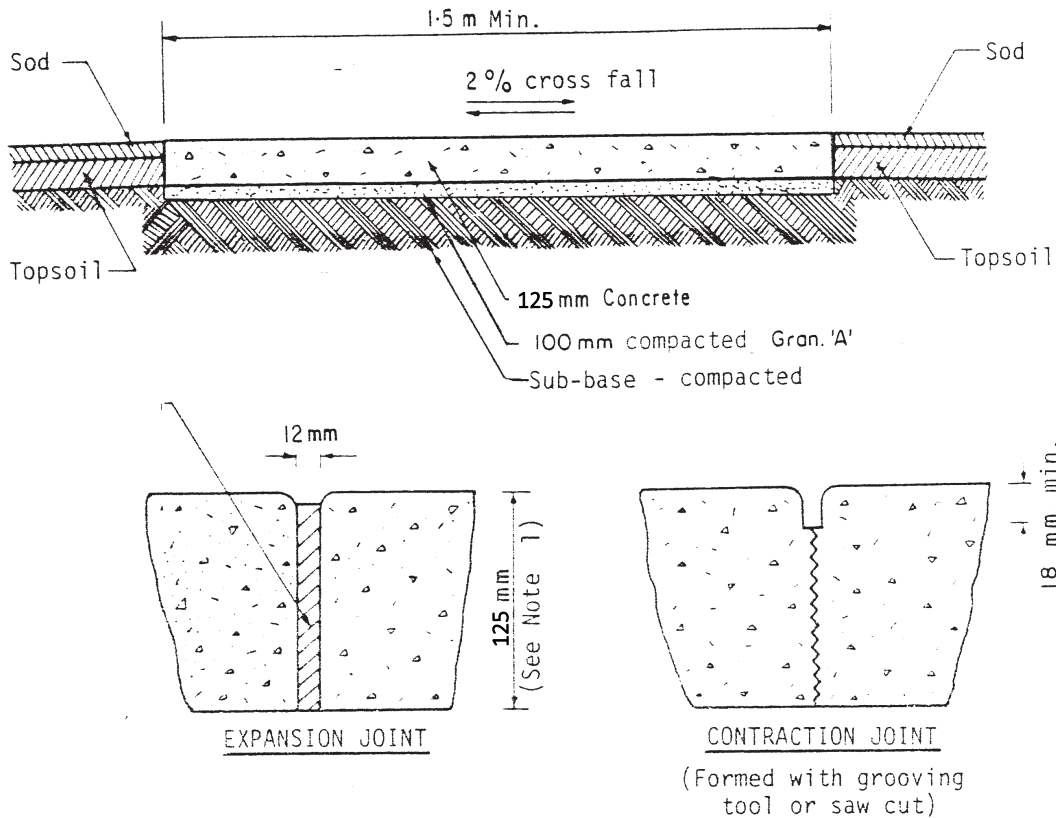

**Notes:**

1. Across industrial, commercial and multi-family ramps the concrete thickness shall be 150mm.
2. All concrete edges to be finished with an edger.
3. Contraction joints shall have a standard spacing of 1.5m, and in no case less than 1m or more than 2m.
4. Expansion joints are required at the following locations:
  - A. Between sidewalk and abutting curb.
  - B. To isolate obstructions from sidewalk, e.g. poles, hydrants, light standards, buildings, etc.
  - C. Intersections of sidewalks and driveways.
  - D. Work interruptions.
5. Class of concrete: 25 MPA
6. Sidewalk to slope towards pavement unless otherwise authorized.

CORPORATION OF THE MUNICIPALITY OF THAMES CENTRE – STANDARD DRAWING

**Concrete Sidewalk**

REVISION DATE:

JAN 2021

DRAWING #:

**R-8**

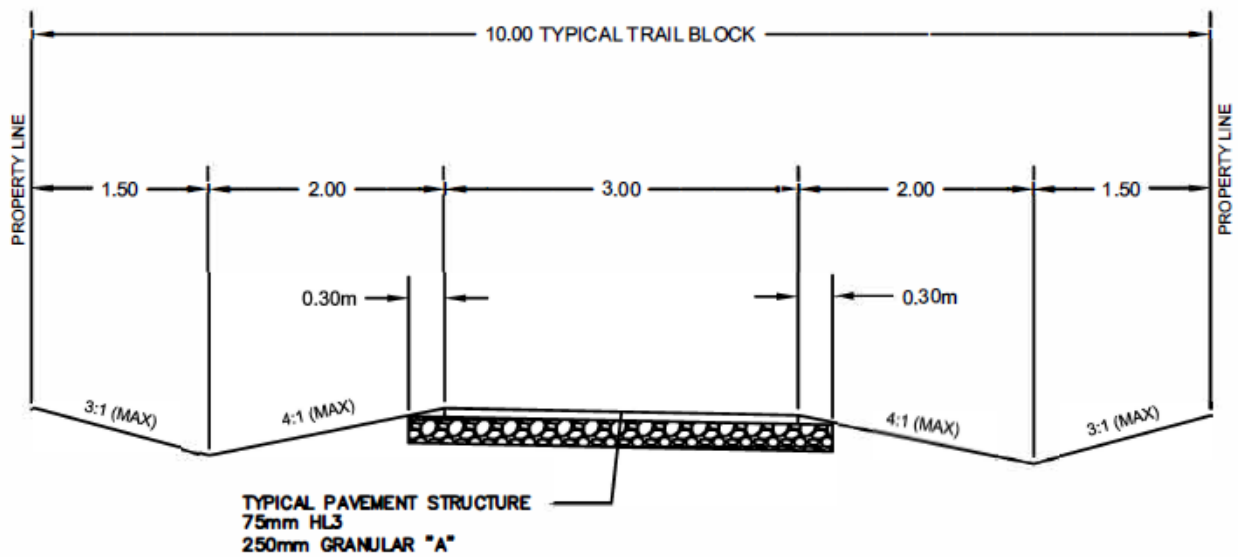

**NOTES:**

1. HARD SURFACE ROOT BARRIER, 60mm THICK, SHALL BE INSTALLED IN THE VICINITY OF ANY TREES
2. ALL DISTURBED AREAS SHALL BE RESTORED WITH 100mm TOPSOIL AND SOD OR HYDROSEED

CORPORATION OF THE MUNICIPALITY OF THAMES CENTRE – STANDARD DRAWING

**Typical Multi-use Trail**

REVISION DATE:

MAR 2021

DRAWING #:

**R-9**

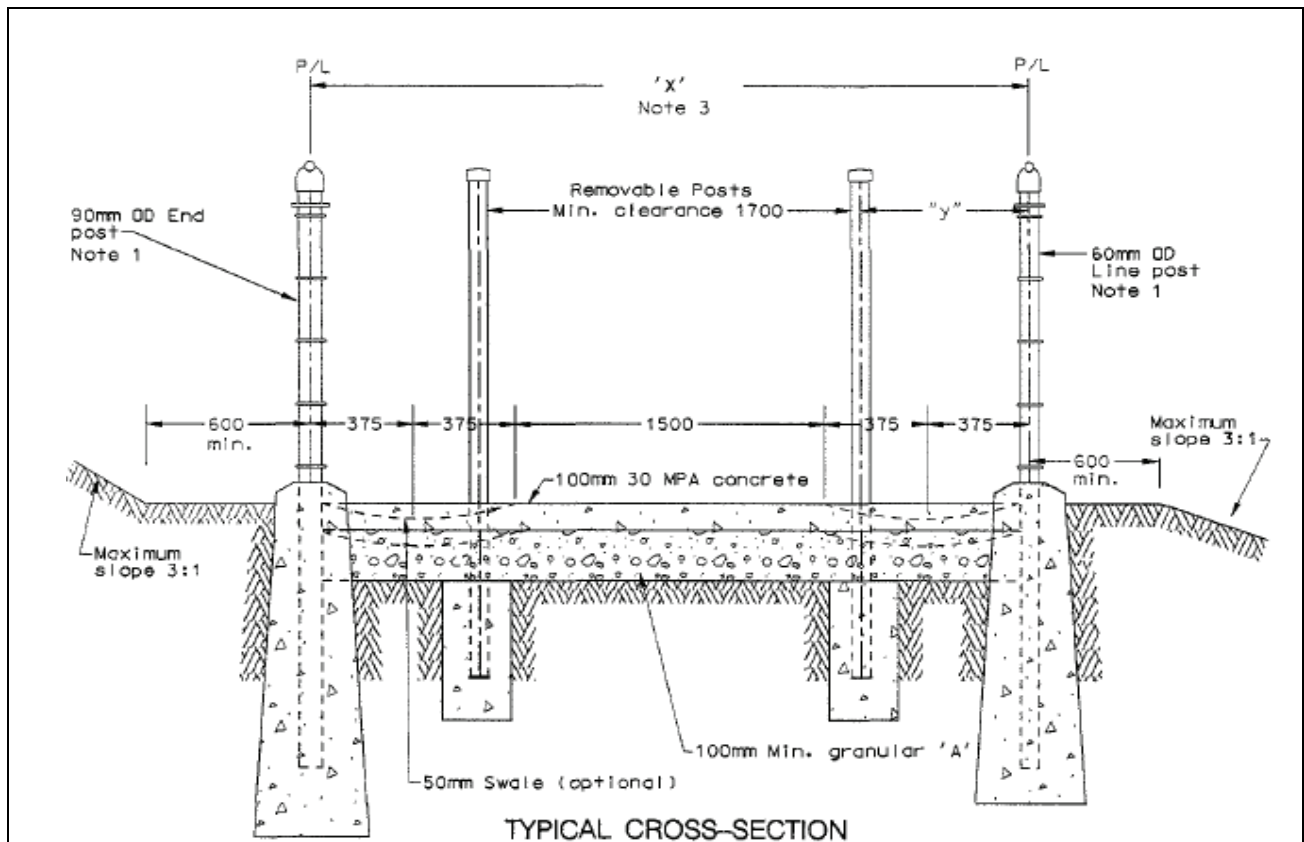

**Notes:**

1. Chain link fence detail shall comply with the requirements of OPSS-541 and OPSD 972.130 except for the following amendments. The height of the fence shall read 1.2 m and the footing detail, part a: in earth is amended to read a: in concrete. In lieu of a chain link fence, an approved wooden fence in accordance with Thames Centre fencing By-laws can be constructed adjacent to the walkway/access entirely on private property. The wooden fence is to terminate 6.0 m from the street line and continue with a 1.2 m wooden fence or a 1.2 m chain link fence to the street line. All wooden fence details are to be reviewed and/or approved by the Director of Public Works and Engineering.
2. In new subdivisions where walkway grades exceed 10% stairs are to be constructed. Walkways constructed with grades between 8% and 10% require pedestrian handrails on one side of the walkway in line with the Removable posts with approval of the Director of Public Works and Engineering. The pedestrian handrail shall conform to OPSD 980.101
3. 'x' varies for 3 m and 4.6 m cross sections. 'y' = 620 for 3 m cross-sections. 'y' = 1420 for 4.6 m cross sections.
4. A crossfall of 2% or alternative swales.
5. Removable posts to be installed in locations indicated on approved drawings.
6. Walkway Lighting to be in accordance with current Middlesex Centre specifications

CORPORATION OF THE MUNICIPALITY OF THAMES CENTRE – STANDARD DRAWING

<b>Standard Pedestrian Walkway</b>	REVISION DATE:	JAN 2021
	DRAWING #:	<b>R-10</b>

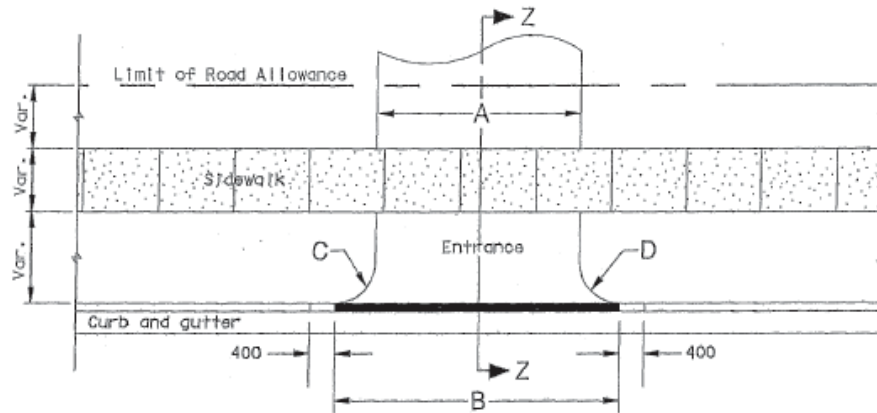

Driveway Entrance Type	Dimension (max./m)			
	A	B	C rad.	D rad.
Single Family (Local & Secondary ROW's)	6.0	7.0	0.5	0.5
Single Family (Other ROW's)	6.0	8.0	0.5	1.5
Multi-family	6.7	12.7	3.0	3.0

Driveway Structure			
Type	HL3 (Note 2)	Gran. 'A'	Gran. 'B'
Single Family	50	150	-
Multi-family	50	300	-

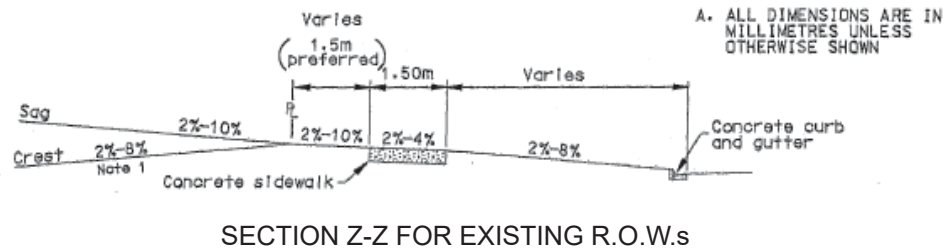
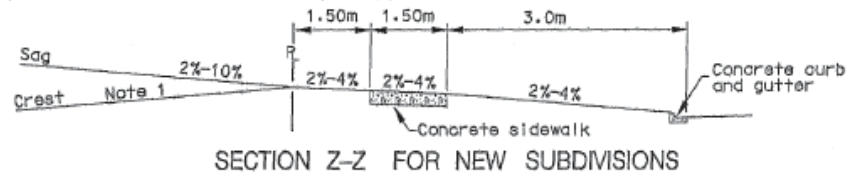

**Notes:**

1. For developments with commercial or multi-family driveway entrances; the vertical grades of access driveways shall be 2% for a minimum distance of 6.0 m back of property line.
2. HL3 can be substituted with other hard surfaces (ie paving stone, concrete) as approved by the Engineer.
3. The maximum driveway width shall be as per Thames Centre Zoning Regulations
4. Grades on reconstructed driveways will vary based on matching existing driveway topography.

CORPORATION OF THE MUNICIPALITY OF THAMES CENTRE – STANDARD DRAWING

**Single Family Driveway Entrances with Boulevard**

REVISION DATE:

JAN 2021

DRAWING #:

**R-11**

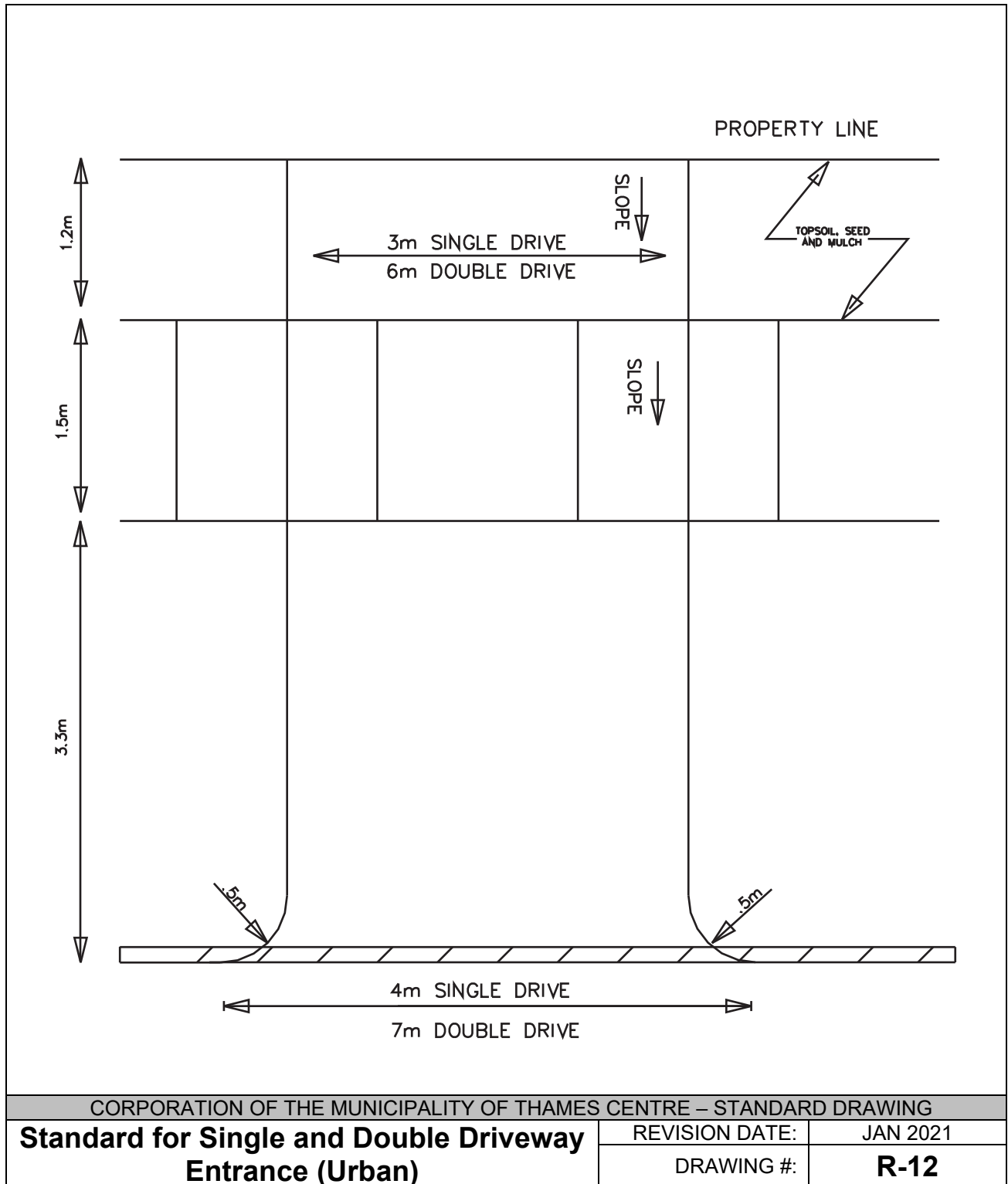

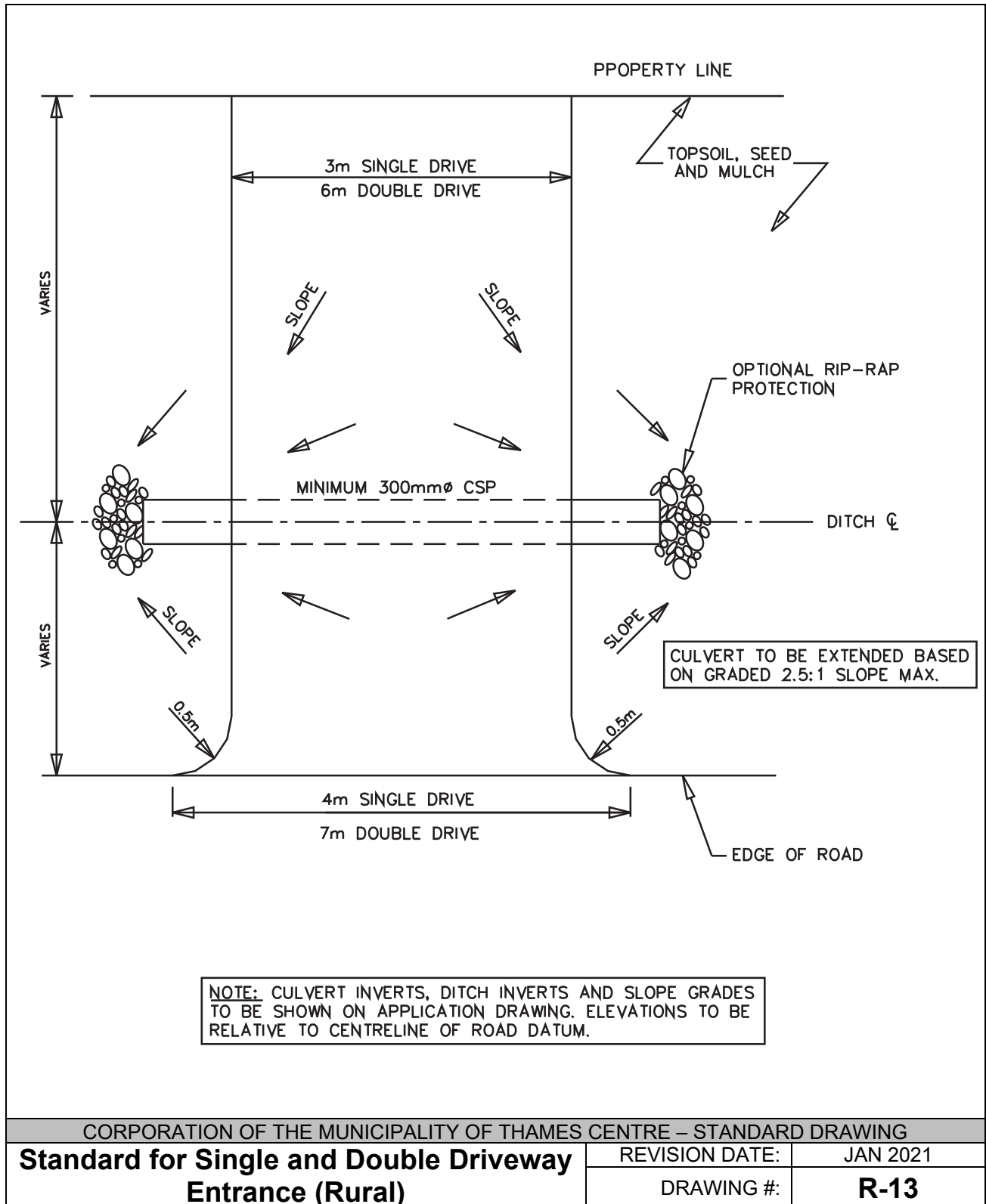

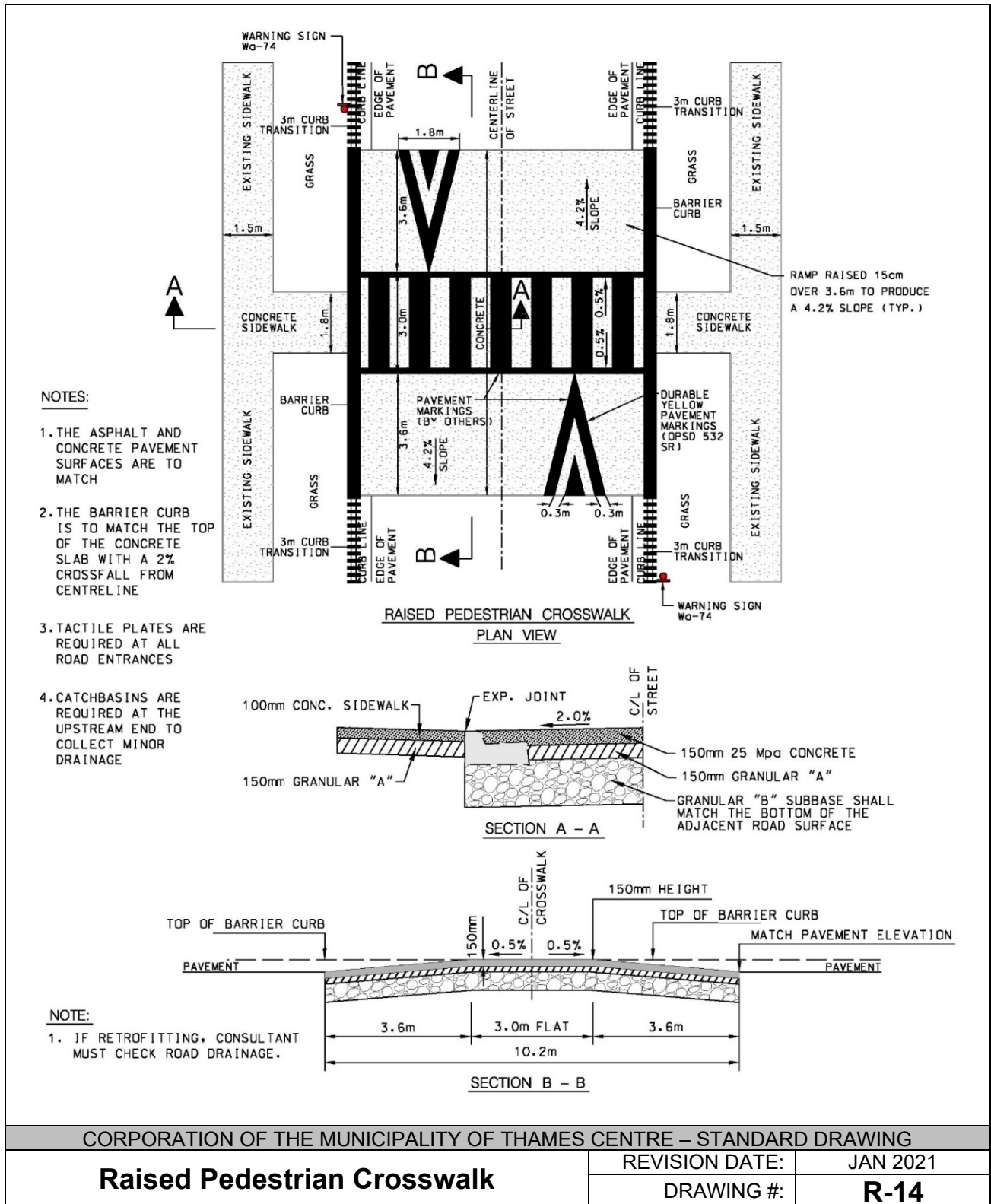

CORPORATION OF THE MUNICIPALITY OF THAMES CENTRE – STANDARD DRAWING

**Raised Pedestrian Crosswalk**

REVISION DATE:

JAN 2021

DRAWING #:

**R-14**

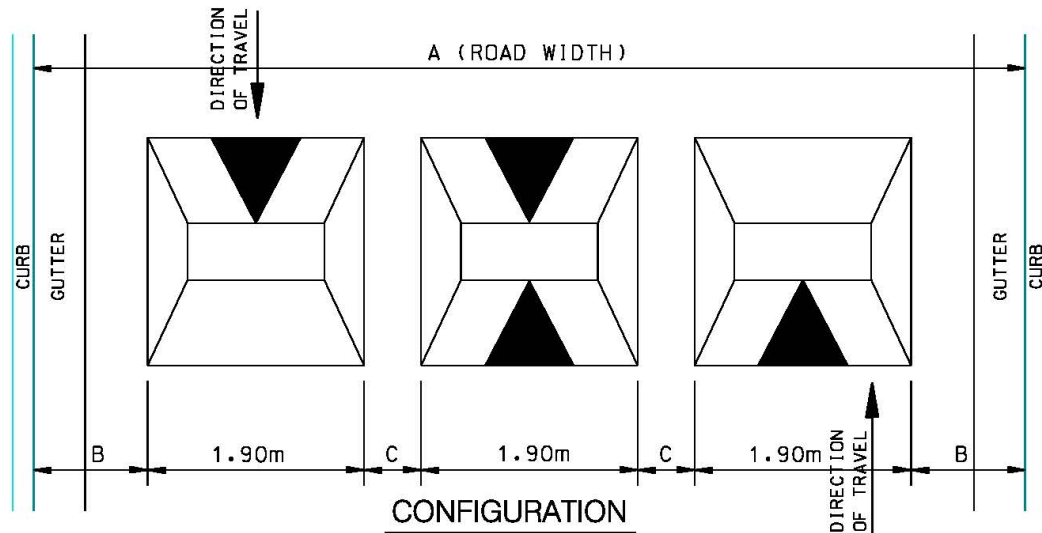
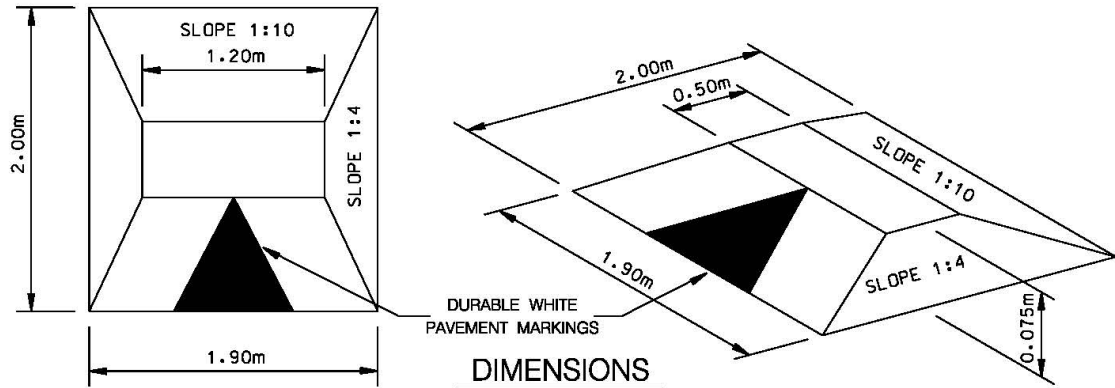

① ADDITIONAL CATCHBASINS MAY BE REQUIRED AT THE UPSTREAM END TO CAPTURE DRAINAGE ASSOCIATED WITH FREEZE-THAW CONDITIONS

② SPEED CUSHIONS SHOULD BE LOCATED TO AVOID CONFLICTS WITH DRIVEWAYS

GENERAL LAYOUT			
ROAD WIDTH A	No. OF CUSHIONS	DIMENSIONS *	
		B	C
8.0m	3	0.75m	0.40m
9.0m	3	1.10m	0.55m
10.0m	4	0.60m	0.40m
11.0m	4	1.00m	0.46m

\* - TO BE CONFIRMED BY THE TRANSPORTATION DIVISION

CORPORATION OF THE MUNICIPALITY OF THAMES CENTRE – STANDARD DRAWING

**Speed Cushion Design**

REVISION DATE:

JAN 2021

DRAWING #:

**R-15**

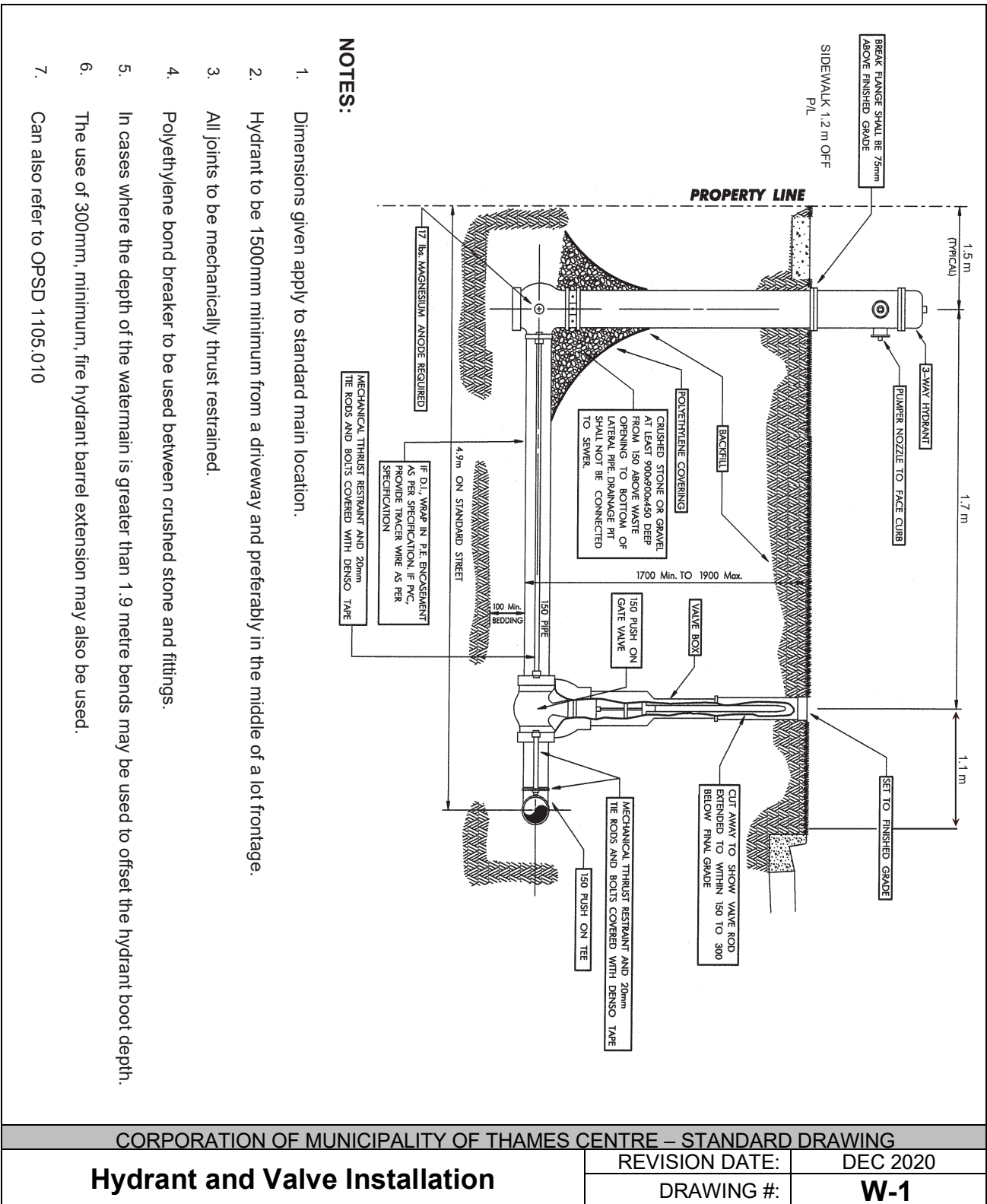

CORPORATION OF MUNICIPALITY OF THAMES CENTRE – STANDARD DRAWING

**Hydrant and Valve Installation**

REVISION DATE:

DEC 2020

DRAWING #:

**W-1**

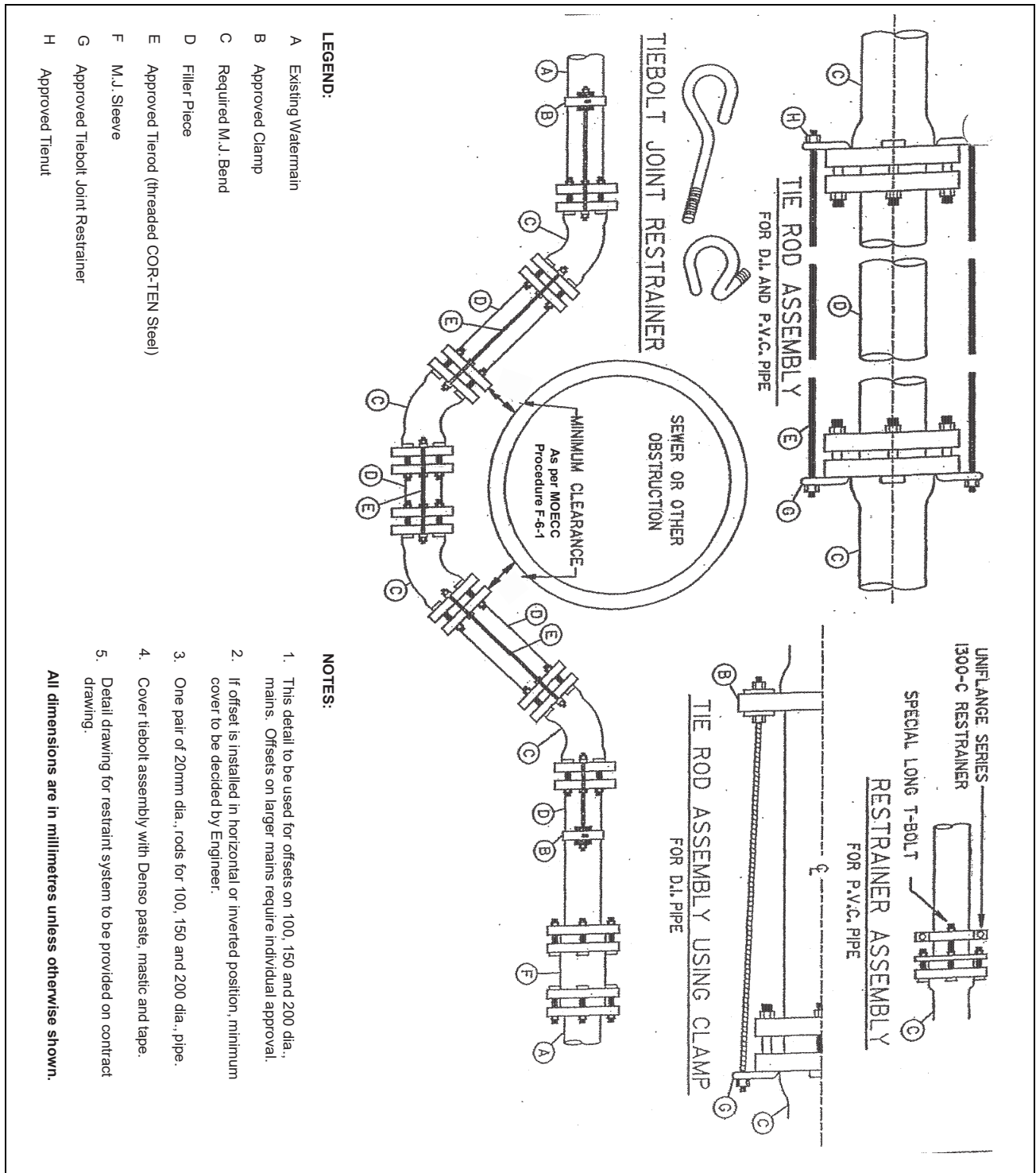

CORPORATION OF MUNICIPALITY OF THAMES CENTRE – STANDARD DRAWING

<b>Standard Mechanical Joint Offset Installation Using Tiebolt Couplings</b>	REVISION DATE:	DEC 2020
	DRAWING #:	<b>W-2</b>

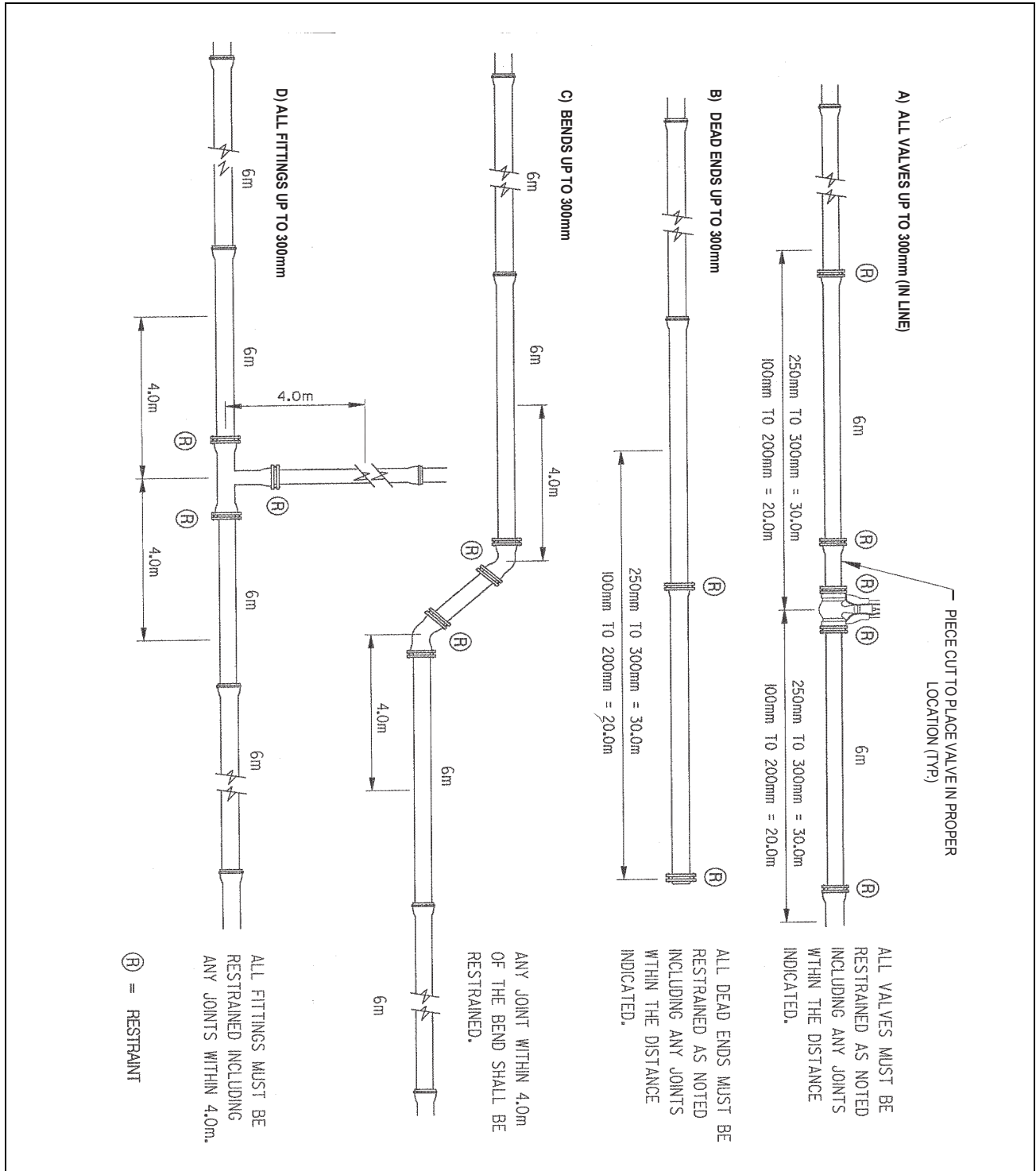

CORPORATION OF MUNICIPALITY OF THAMES CENTRE – STANDARD DRAWING

**Typical Restraint Details**

REVISION DATE:

DEC 2020

DRAWING #:

**W-3**

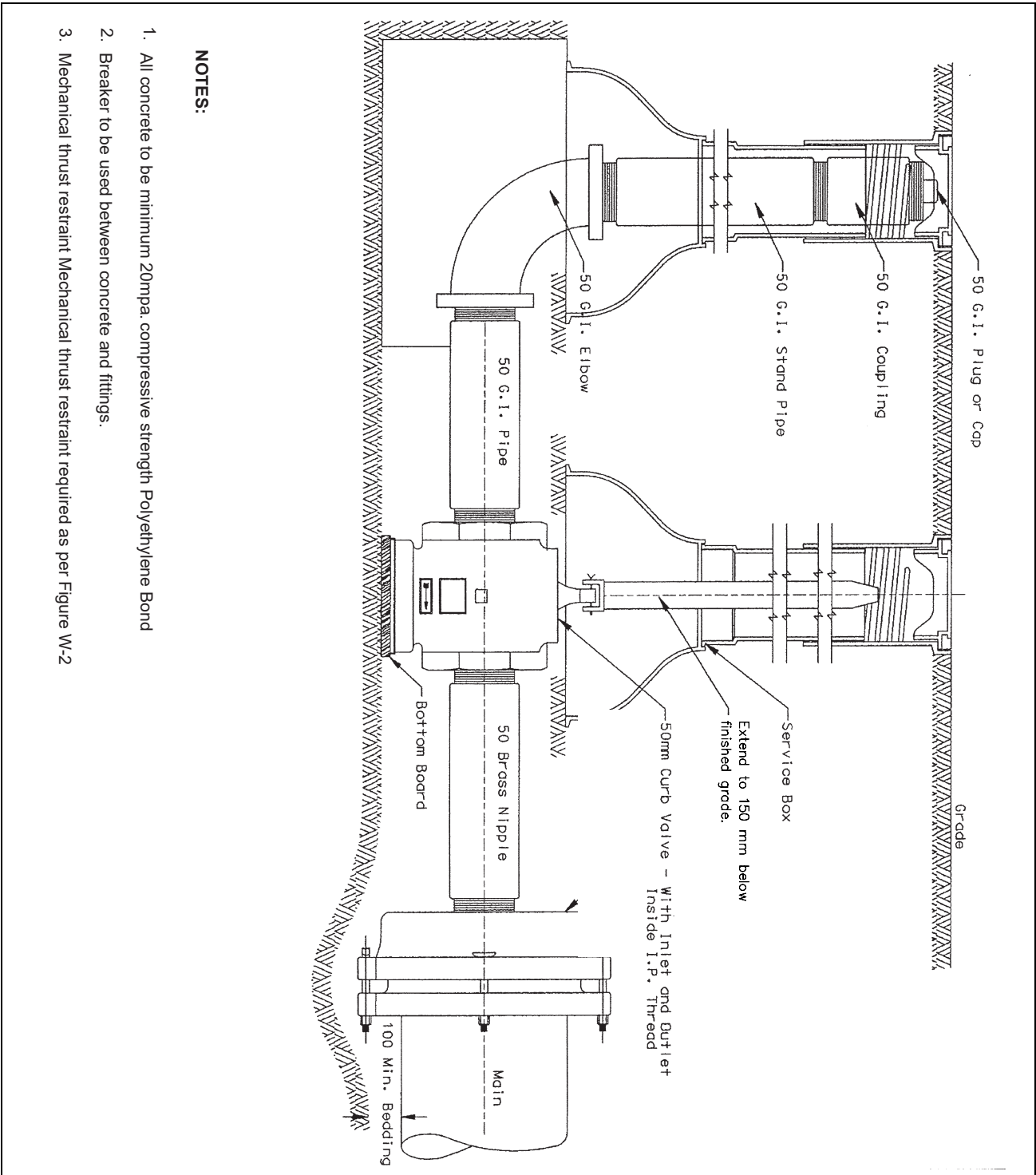

**NOTES:**

1. All concrete to be minimum 20mpa. compressive strength Polyethylene Bond
2. Breaker to be used between concrete and fittings.
3. Mechanical thrust restraint Mechanical thrust restraint required as per Figure W-2

CORPORATION OF MUNICIPALITY OF THAMES CENTRE – STANDARD DRAWING

**Standard 50 mm Blow Off Installation**

REVISION DATE:

DEC 2020

DRAWING #:

**W-4**

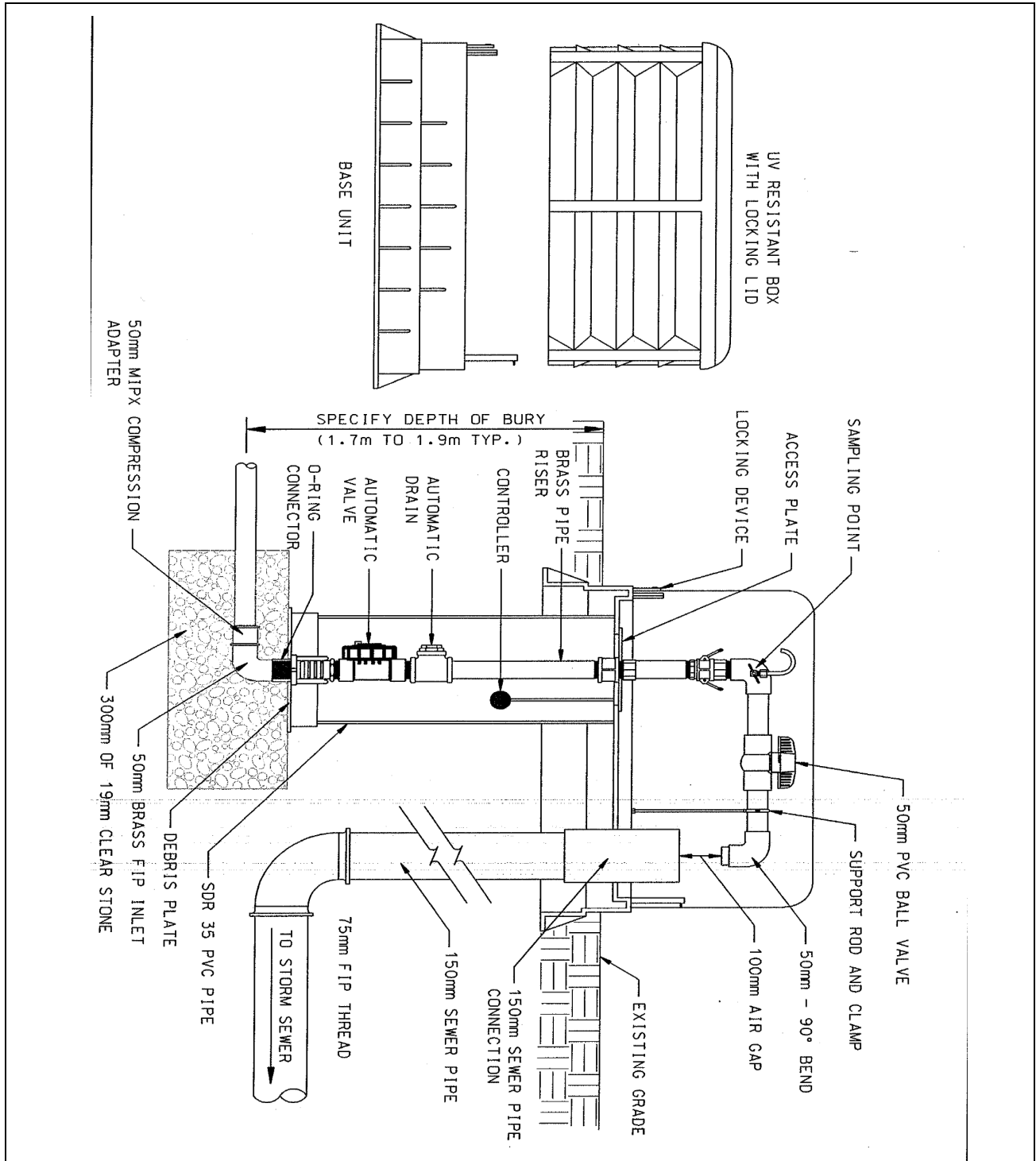

CORPORATION OF MUNICIPALITY OF THAMES CENTRE – STANDARD DRAWING

**9800 Flushing Device Detail**

REVISION DATE:

DEC 2020

DRAWING #:

**W-5**

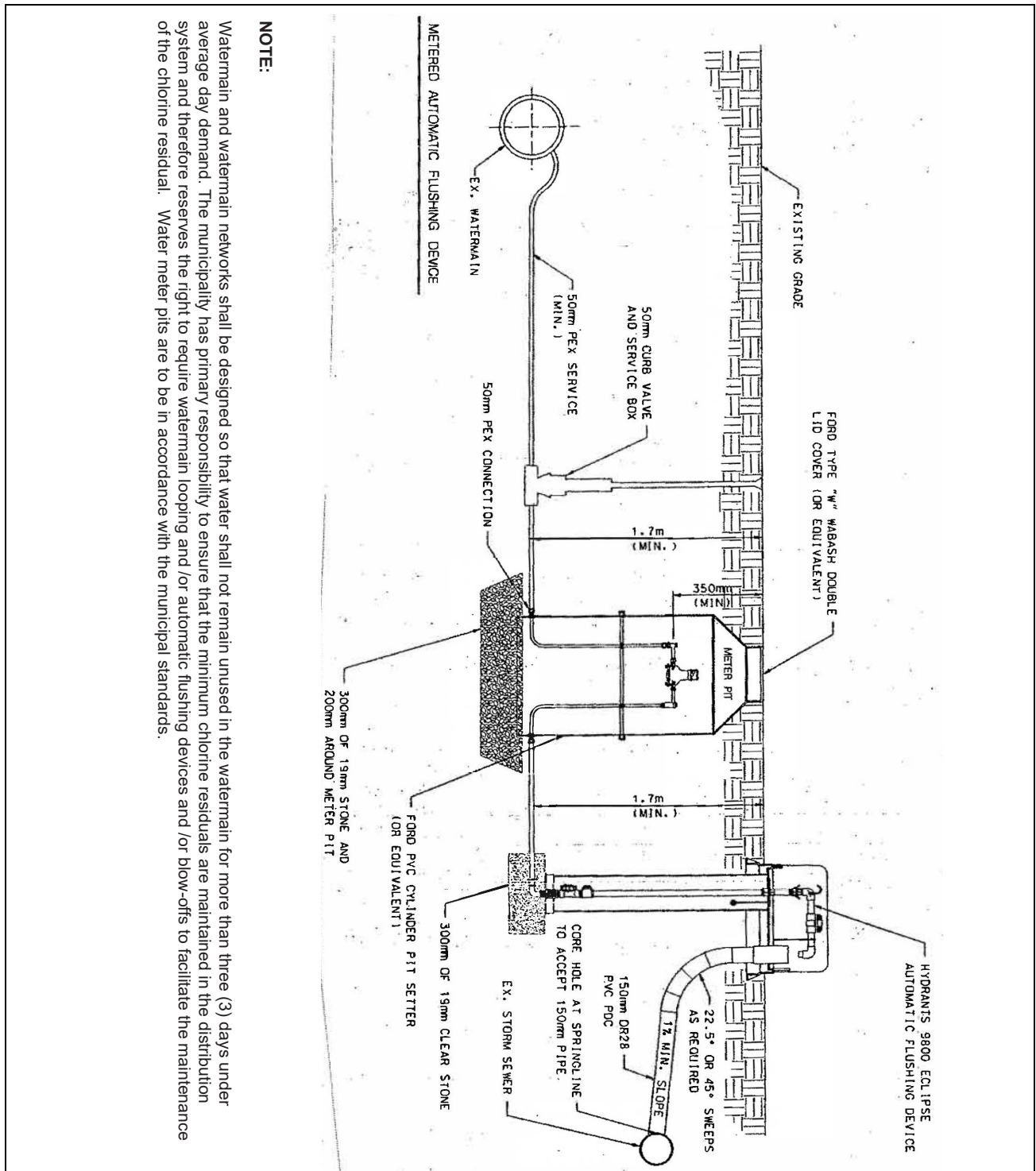

**NOTE:**

Watermain and watermain networks shall be designed so that water shall not remain unused in the watermain for more than three (3) days under average day demand. The municipality has primary responsibility to ensure that the minimum chlorine residuals are maintained in the distribution system and therefore reserves the right to require watermain looping and/or automatic flushing devices and/or blow-offs to facilitate the maintenance of the chlorine residual. Water meter pits are to be in accordance with the municipal standards.

CORPORATION OF MUNICIPALITY OF THAMES CENTRE – STANDARD DRAWING		
<b>Metered Automatic Flushing Device Detail</b>	REVISION DATE:	DEC 2020
	DRAWING #:	<b>W-6</b>

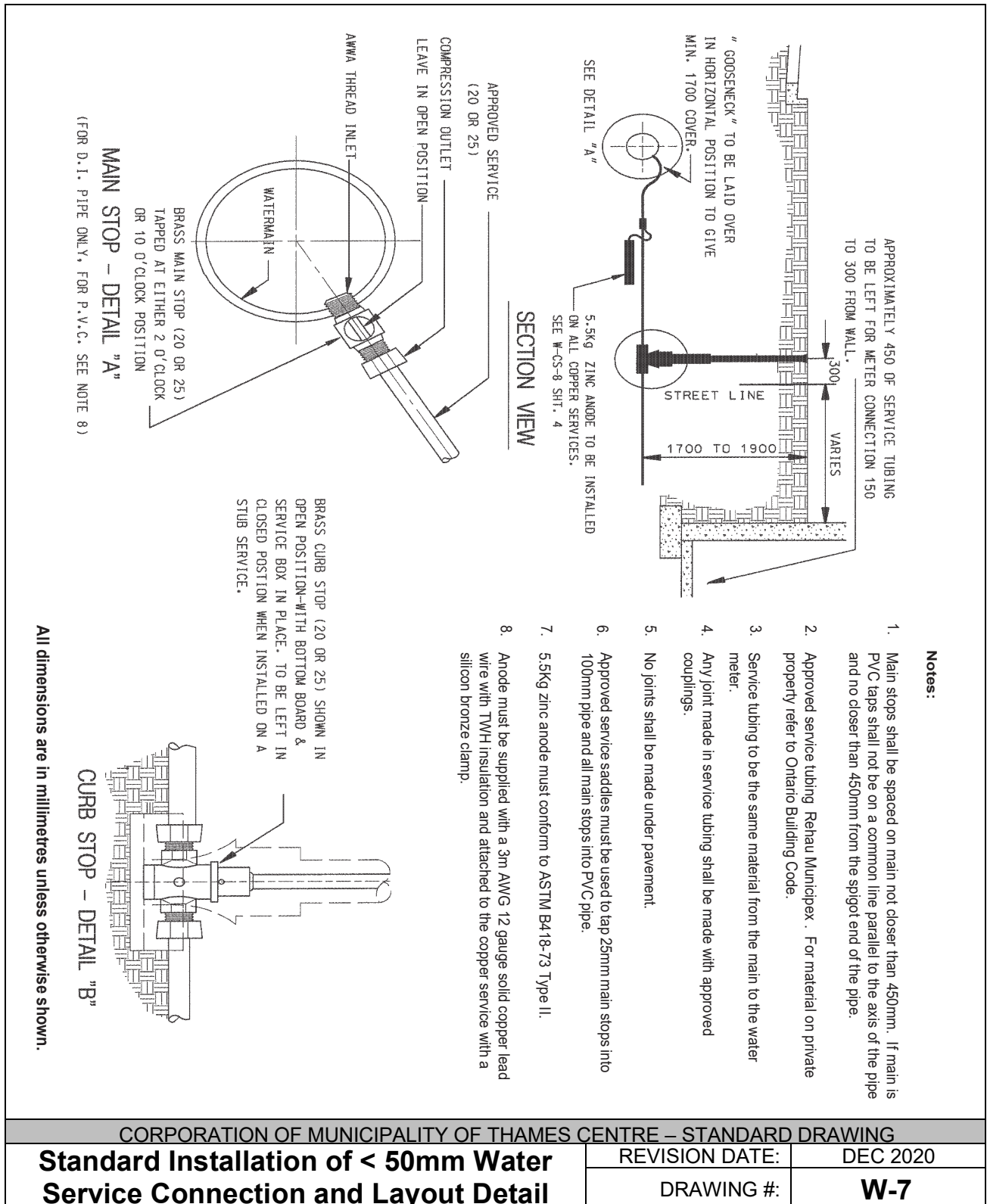

CORPORATION OF MUNICIPALITY OF THAMES CENTRE – STANDARD DRAWING

**Standard Installation of < 50mm Water Service Connection and Layout Detail**

REVISION DATE:

DEC 2020

DRAWING #:

**W-7**

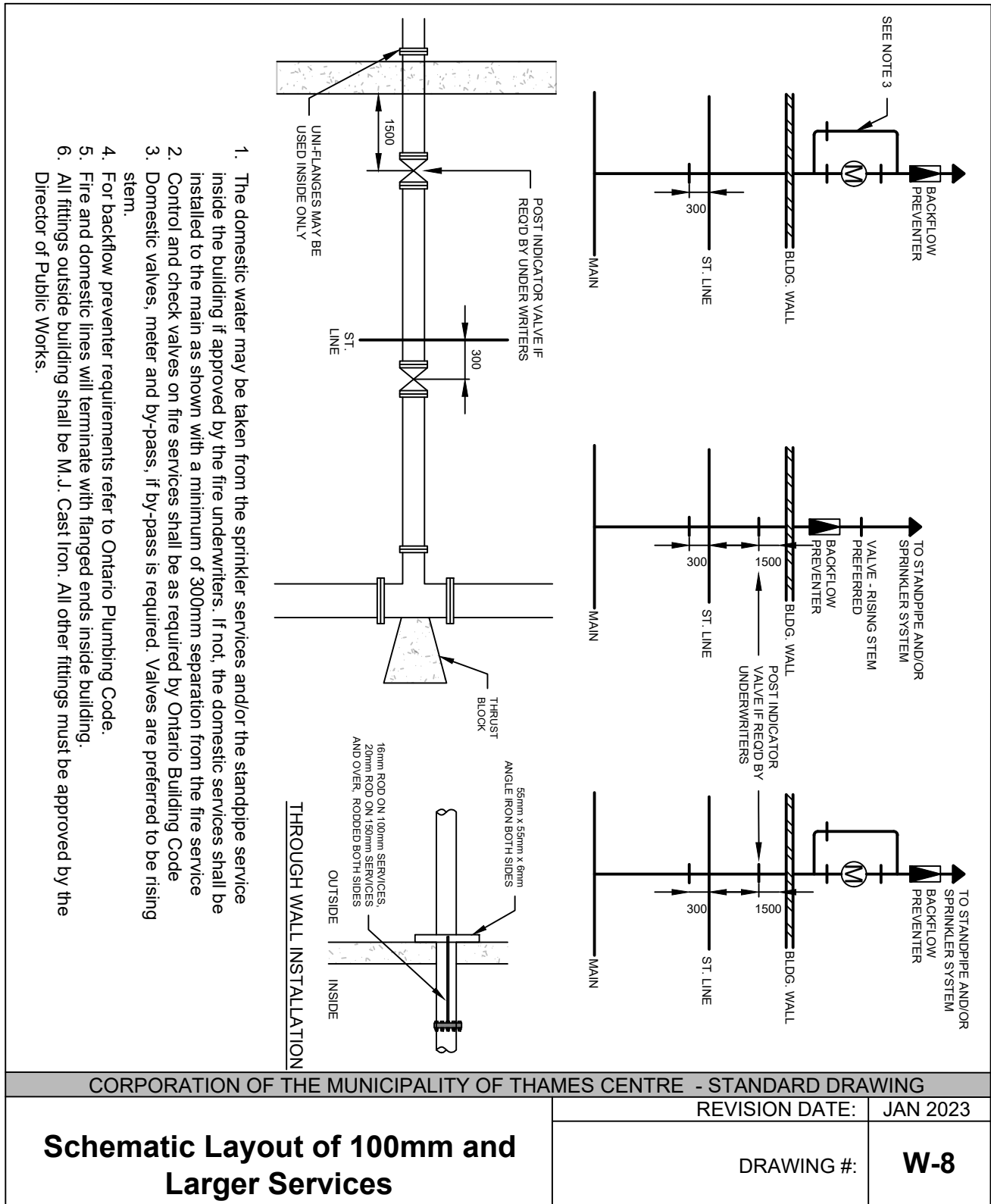

1. The domestic water may be taken from the sprinkler services and/or the standpipe service inside the building if approved by the fire underwriters. If not, the domestic services shall be installed to the main as shown with a minimum of 300mm separation from the fire service
2. Control and check valves on fire services shall be as required by Ontario Building Code
3. Domestic valves, meter and by-pass, if by-pass is required. Valves are preferred to be rising stem.
4. For backflow preventer requirements refer to Ontario Plumbing Code.
5. Fire and domestic lines will terminate with flanged ends inside building.
6. All fittings outside building shall be M.J. Cast Iron. All other fittings must be approved by the Director of Public Works.

CORPORATION OF THE MUNICIPALITY OF THAMES CENTRE - STANDARD DRAWING

REVISION DATE: JAN 2023

**Schematic Layout of 100mm and Larger Services**

DRAWING #: **W-8**

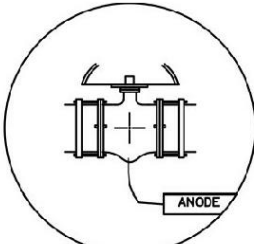
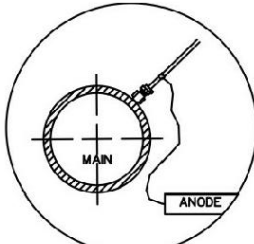
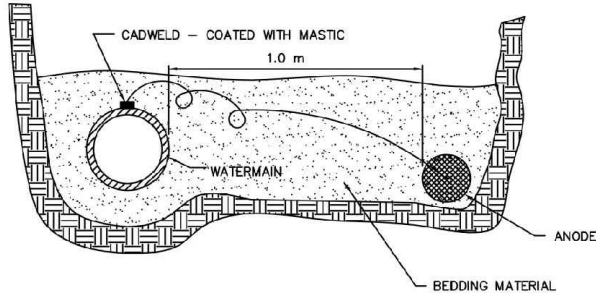
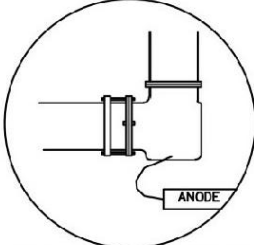
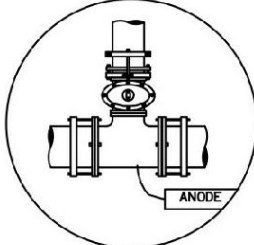
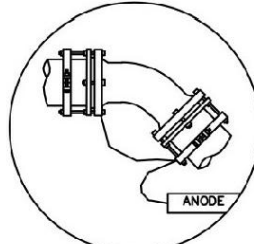
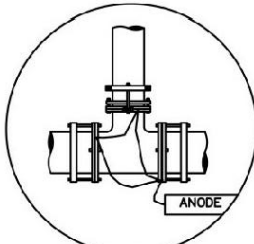
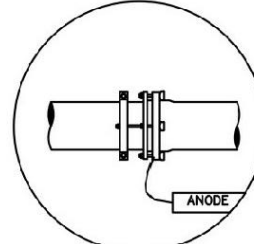
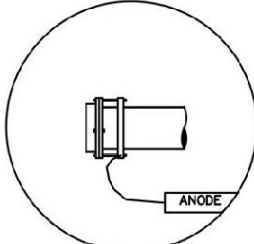
 <p>7.7 kg ANODE FOR EACH VALVE WITH RESTRAINT ASSEMBLY</p>	 <p>2.7 kg ANODE CLAMPED TO EACH COPPER WATER SERVICE</p>	
 <p>7.7 kg ANODE FOR EACH HYDRANT WITH RESTRAINT ASSEMBLY</p>	 <p>7.7 kg ANODE FOR EACH ANCHOR TEE AND VALVE WITH RESTRAINT ASSEMBLY</p>	
 <p>BENDS AND REDUCERS ARE TO BE PROTECTED WITH ONE (1) 7.7kg ANODE WITH JUMPER CABLE OR TWO (2) 2.7 kg ANODES CONNECTED INDIVIDUALLY. AN M.J. FITTING WITH RESTRAINTS REQUIRES ONE (1) 7.7 kg ANODE.</p>	 <p>7.7 kg ANODE WITH JUMPER CONNECTIONS TO EACH OF THE THREE (3) RESTRAINTS ON THE PVC TEE OR CONNECTED DIRECTLY TO THE M.J. TEE. THE SAME APPLICATION APPLIES TO THE FOUR (4) RESTRAINTS ON A CROSS.</p>	
 <p>2.7 kg ANODE PER RESTRAINT OR ONE (1) 7.7 kg ANODE FOR THREE (3) RESTRAINTS IF WITHIN 3.0 m.</p>	 <p>7.7 kg ANODE FOR A RESTRAINT ON A CAP OR A PLUG AT A DEAD END</p>	

**Notes:**

1. All anode connections shall be cadweld connections unless otherwise stated
2. All jumper connections shall be made with a minimum #10 gauge RWU90 wire
3. Anodes shall be saturated with water prior to backfill

CORPORATION OF THE MUNICIPALITY OF THAMES CENTRE - STANDARD DRAWING	
<b>Magnesium Anode Configuration for various Metallic Fittings</b>	REVISION DATE: JAN 2023  DRAWING #: <b>W-9</b>

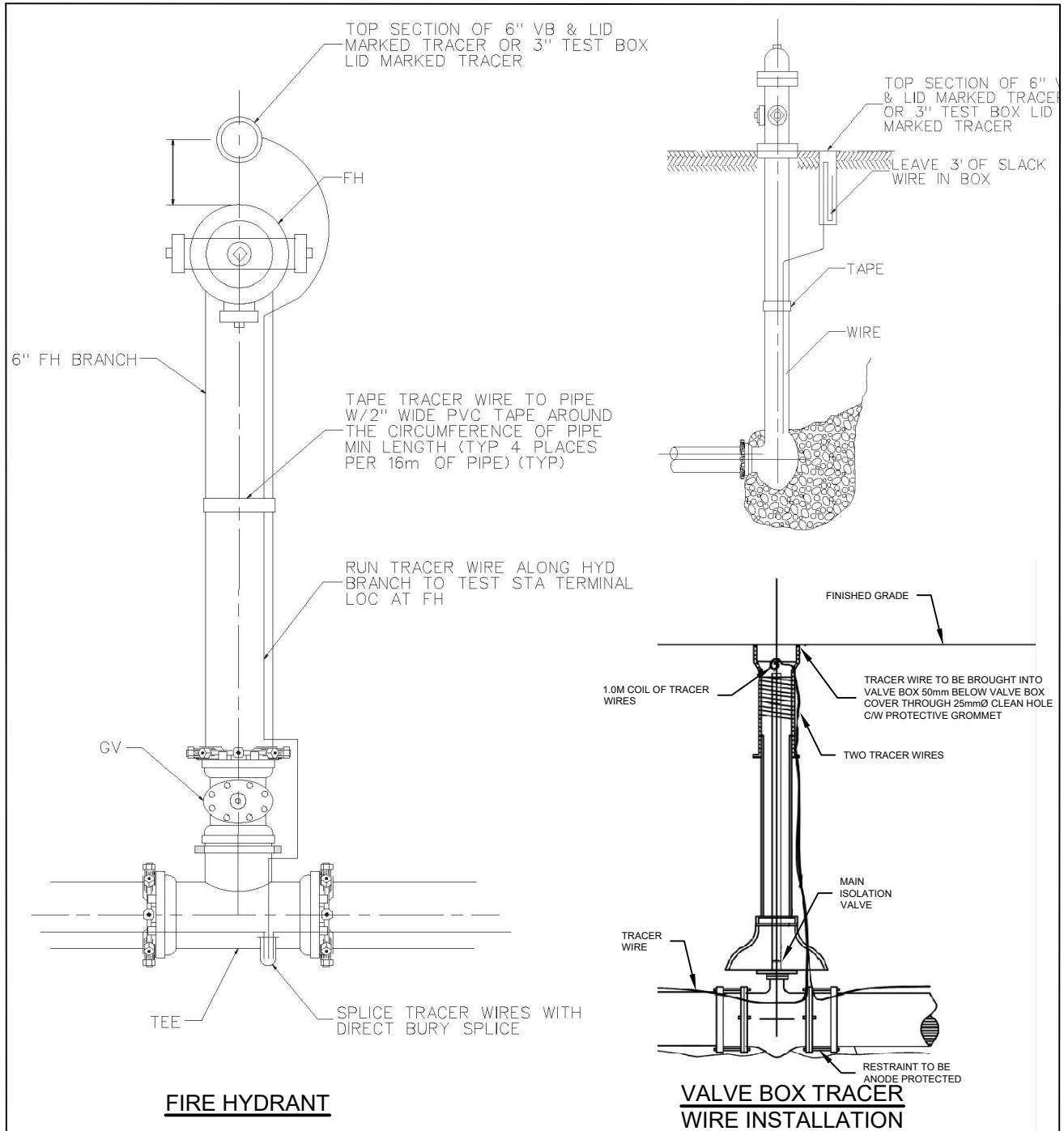

CORPORATION OF THE MUNICIPALITY OF THAMES CENTRE - STANDARD DRAWING

**TRACER WIRE  
INSTALLATION**

REVISION DATE: JAN 2023

DRAWING #: **W-10**

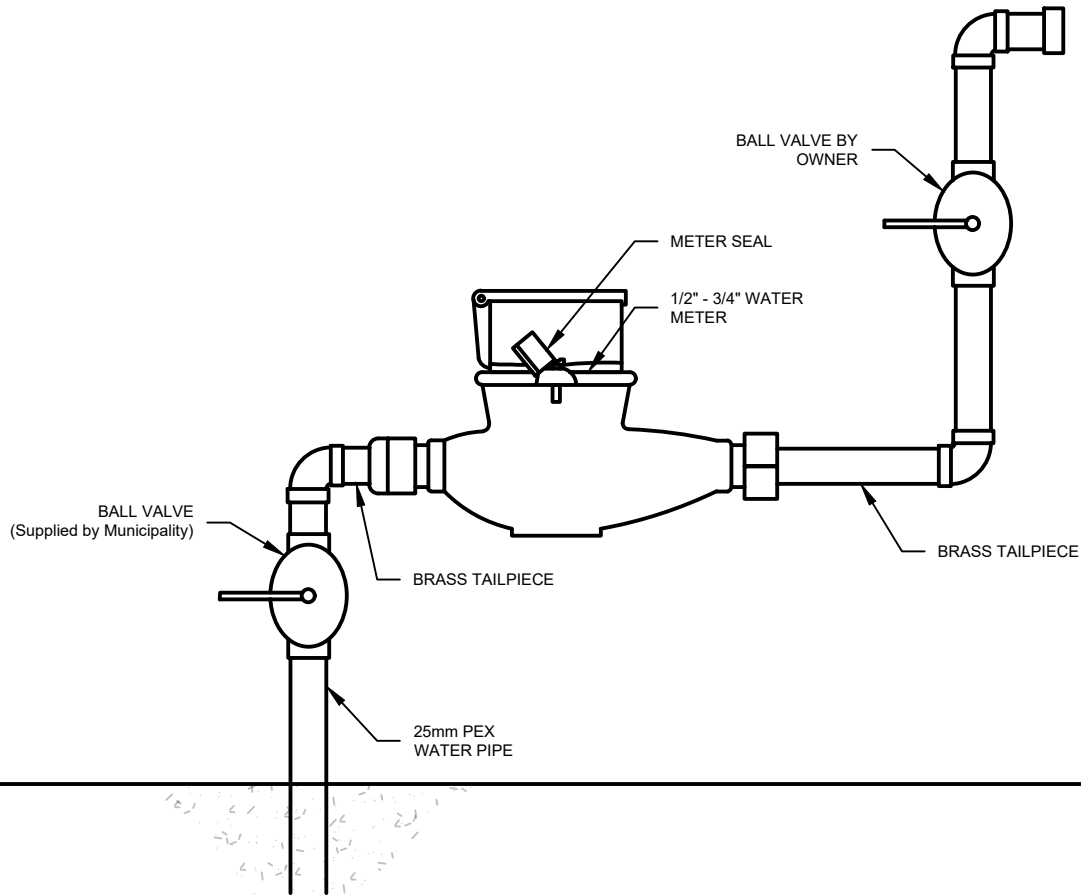

**Notes:**

1. The meter is to be installed in a horizontal position as close as possible to the front foundation wall of the incoming water service entrance (within 1m of the wall)
2. Meter to be kept from freezing (do not install in a cold room)
3. Meter to be accessible for changing and maintenance
4. Meter to be properly supported
5. A 25mm servicing line shut-off valve to be installed within 0.5m of where the service enters through the wall/ floor of the customer's premises and a second valve is to be installed on the outlet side of the water meter
6. Meter and tail pieces to be supplied by the Municipality for new builds

CORPORATION OF THE MUNICIPALITY OF THAMES CENTRE - STANDARD DRAWING

**Standard Installation of Water  
Meters Less than 25mm**

REVISION DATE: JAN 2023

DRAWING #: **W-11**

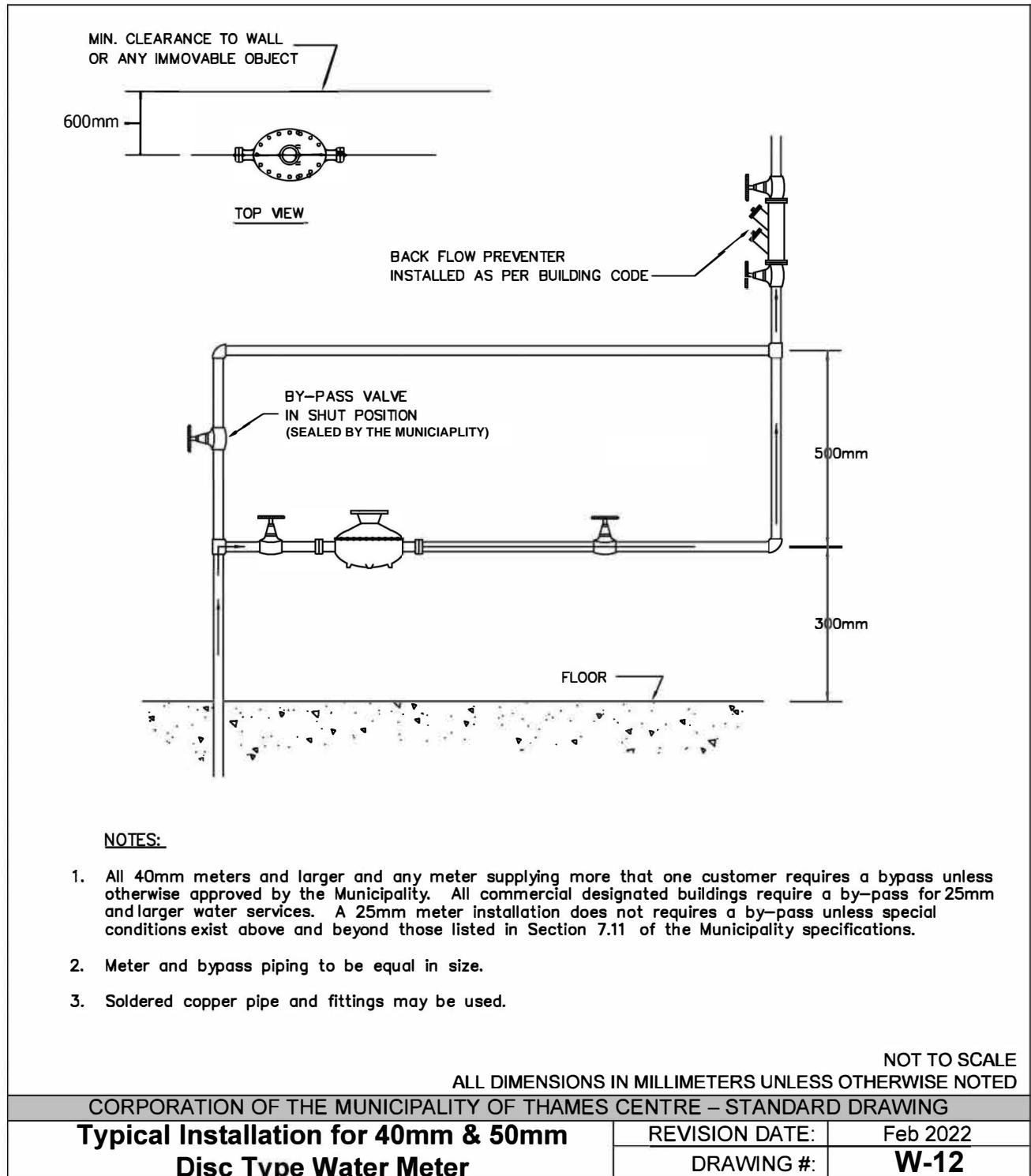

THE CORPORATION OF THE CITY OF LONDON  
DESIGN SPECIFICATIONS AND REQUIREMENTS MANUAL  
FIGURE 5.2 - Rainfall Intensity - Duration - Frequency Curves

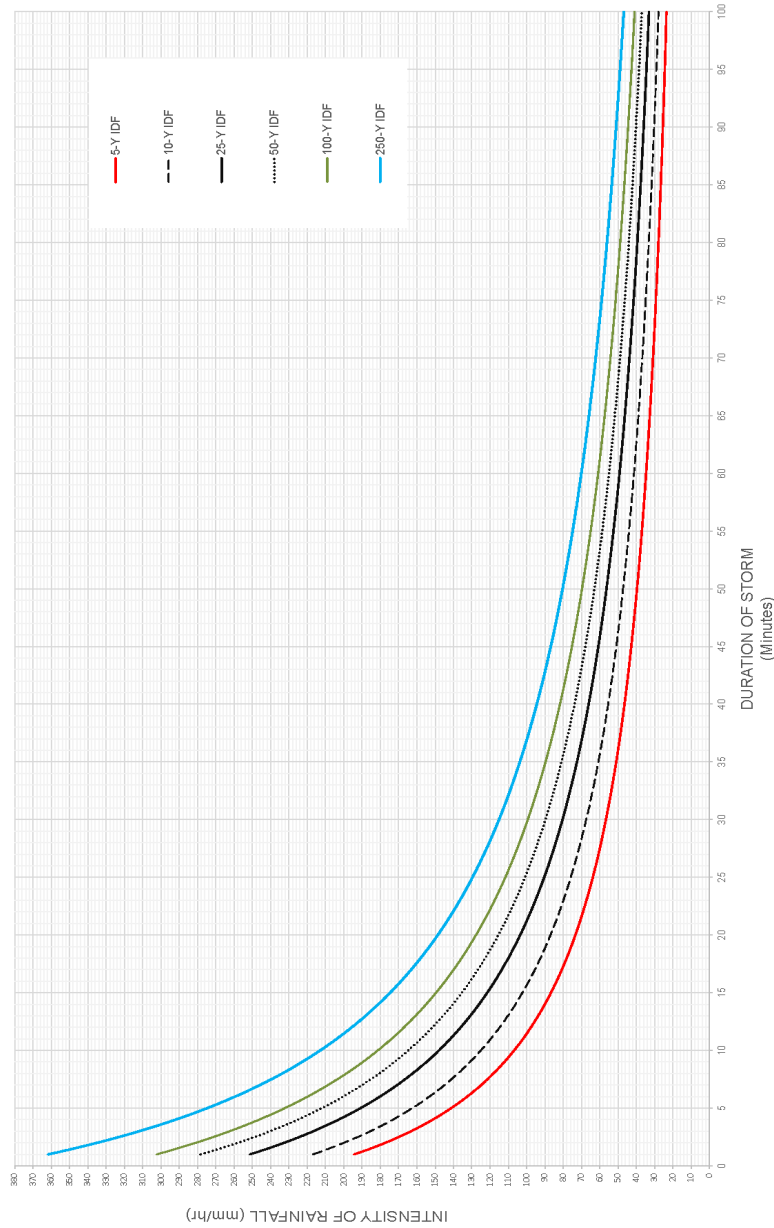

CORPORATION OF MUNICIPALITY OF THAMES CENTRE – STANDARD DRAWING

**Rainfall Intensity – Duration Curves**  
Storm Sewer Design

REVISION DATE: NOV 2020

DRAWING #: **S-1**

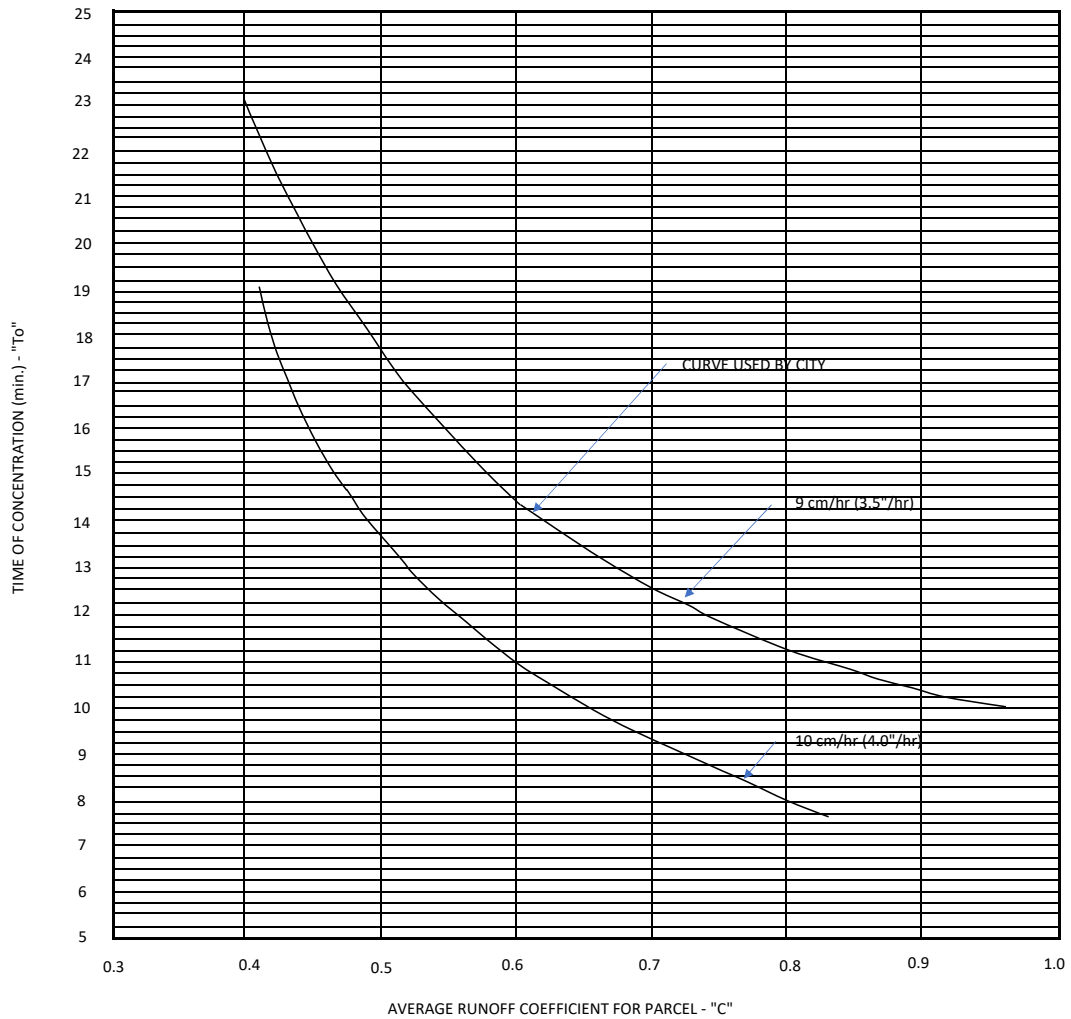

CORPORATION OF MUNICIPALITY OF THAMES CENTRE – STANDARD DRAWING

**Average Runoff Coefficient to Time of Concentration**

REVISION DATE: NOV 2020

DRAWING #: **S-2**

$$H_L = K_L \frac{V^2}{2g}$$

$R$  = Centerline Radius of Bend (m)  
 $D$  = Diameter of Largest Pipe (m)

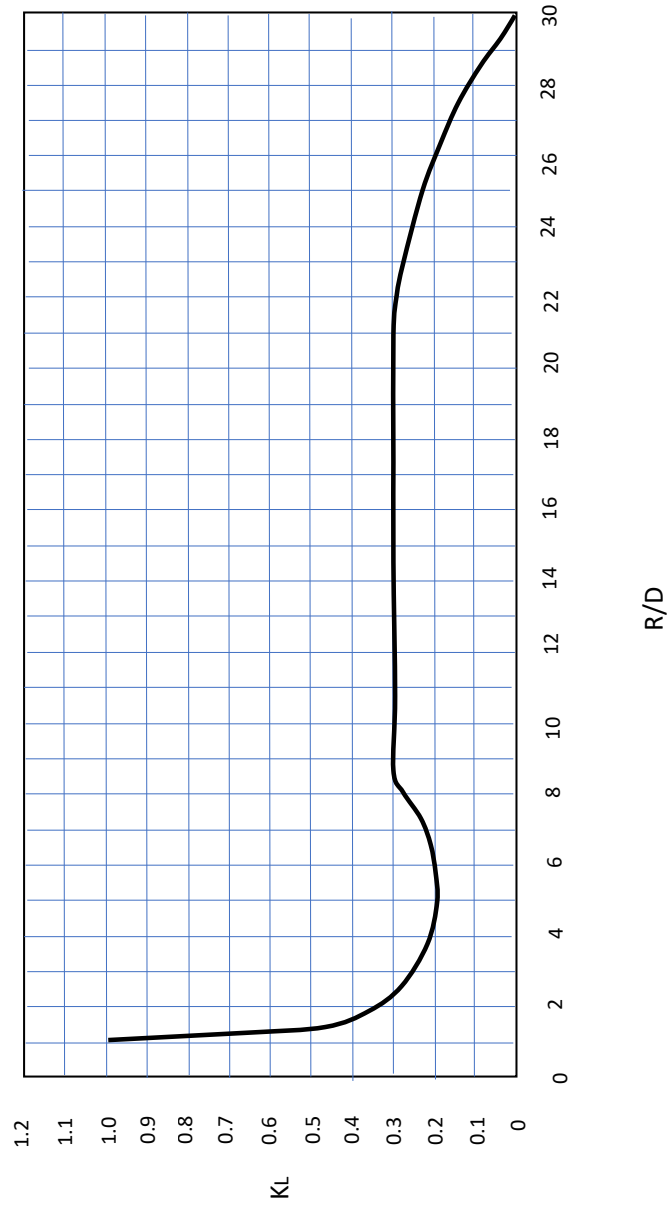

CORPORATION OF MUNICIPALITY OF THAMES CENTRE – STANDARD DRAWING

**KL Values for Calculating Head Losses in Curved Sewers**

REVISION DATE:

NOV 2020

DRAWING #:

**S-3**

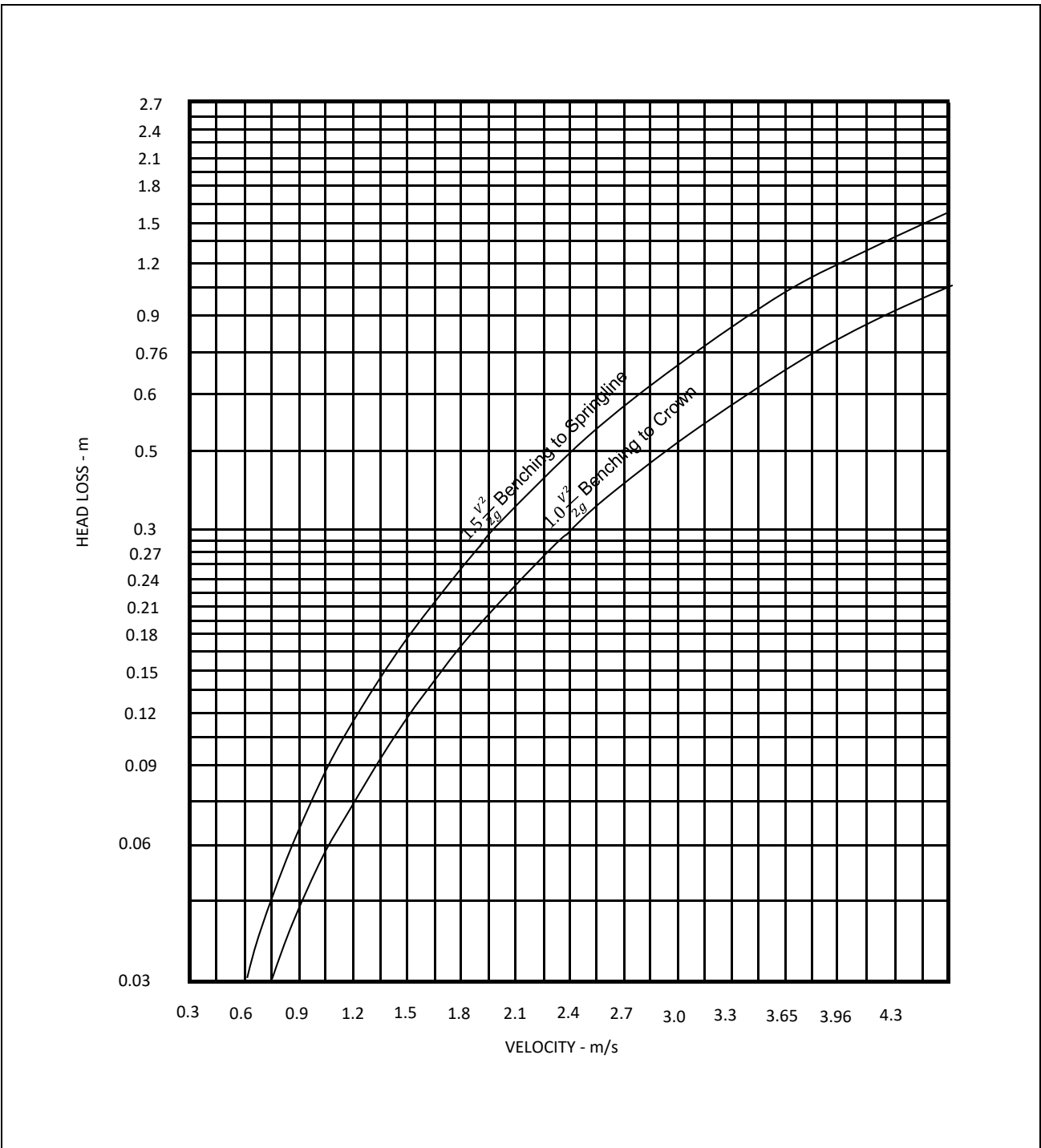











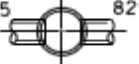

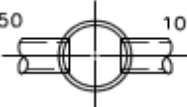
CORPORATION OF MUNICIPALITY OF THAMES CENTRE – STANDARD DRAWING

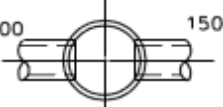
**Head Losses in Maintenance Holes**

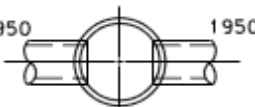
REVISION DATE: NOV 2020

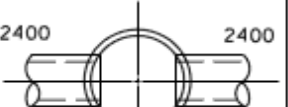
DRAWING #: **S-4**

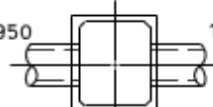
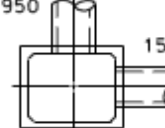
MAINTENANCE HOLE (INSIDE DIAMETER (mm))	MAX. PIPE SIZE FOR STRAIGHT THROUGH INSTALLATION (mm)	MAX. PIPE SIZE FOR RIGHT ANGLE INSTALLATION (mm)
1200	600  600	 450 450
1500	825  825	 600 600
1800	1050  1050	 825 825
2400	1500  1500	 1050 1050
3000	1950  1950	 1500 1500
3600	2400  2400	 1650 1650
3000 x 2400	1950  1950	 1500 1500

**Notes:**

1. All dimensions are for concrete pipes.
2. All dimensions are in millimeters.
3. Information taken from the Ontario Concrete Pipe Association (O.C.P.A)
4. Knockouts for small diameter catch basin lead sizes 300 mm or less could be provided in addition to what is shown.

CORPORATION OF MUNICIPALITY OF THAMES CENTRE – STANDARD DRAWING

<b>Maximum Pipe Sizes for Precast Maintenance Holes</b>	REVISION DATE:	NOV 2020
	DRAWING #:	<b>S-5</b>

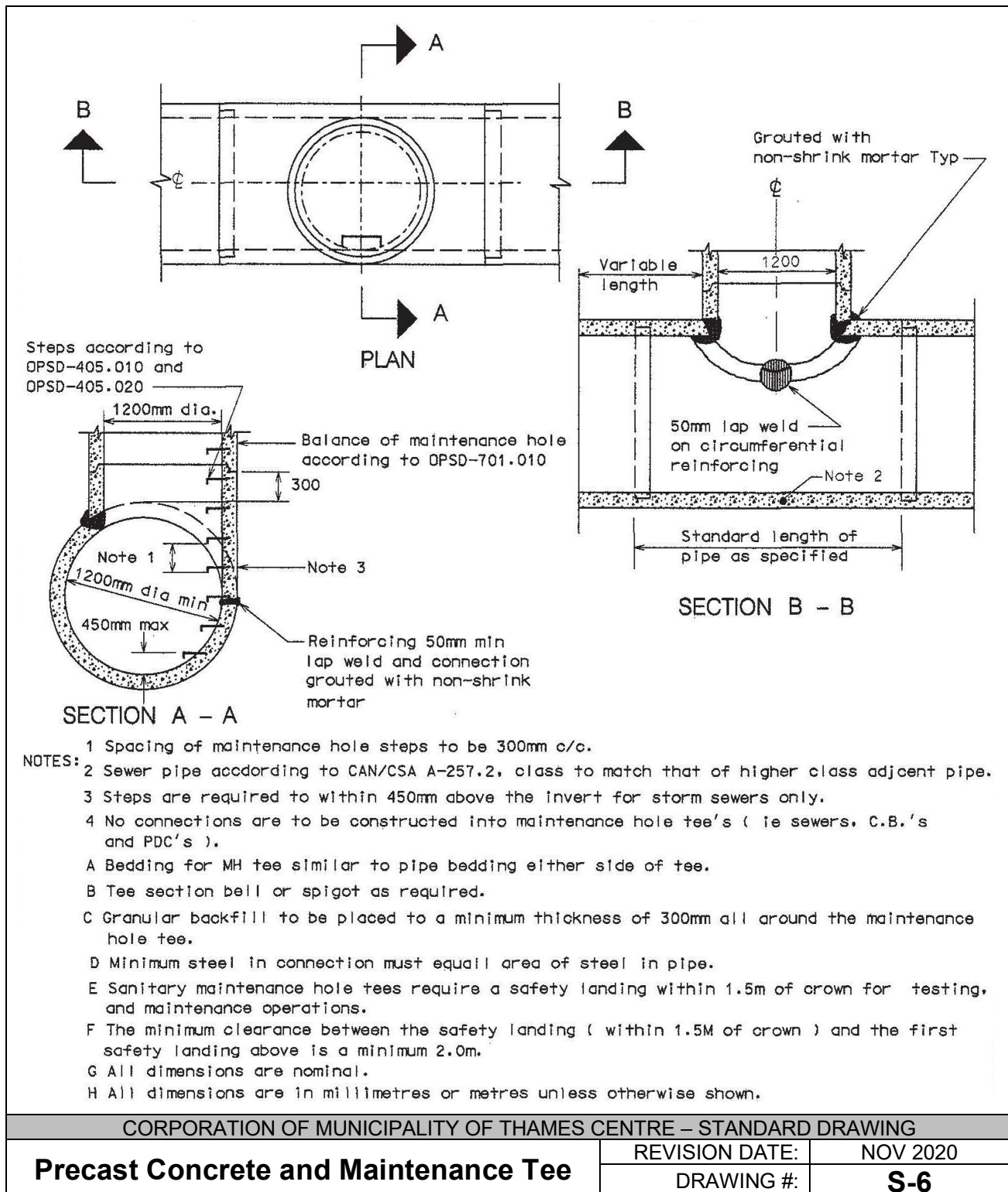

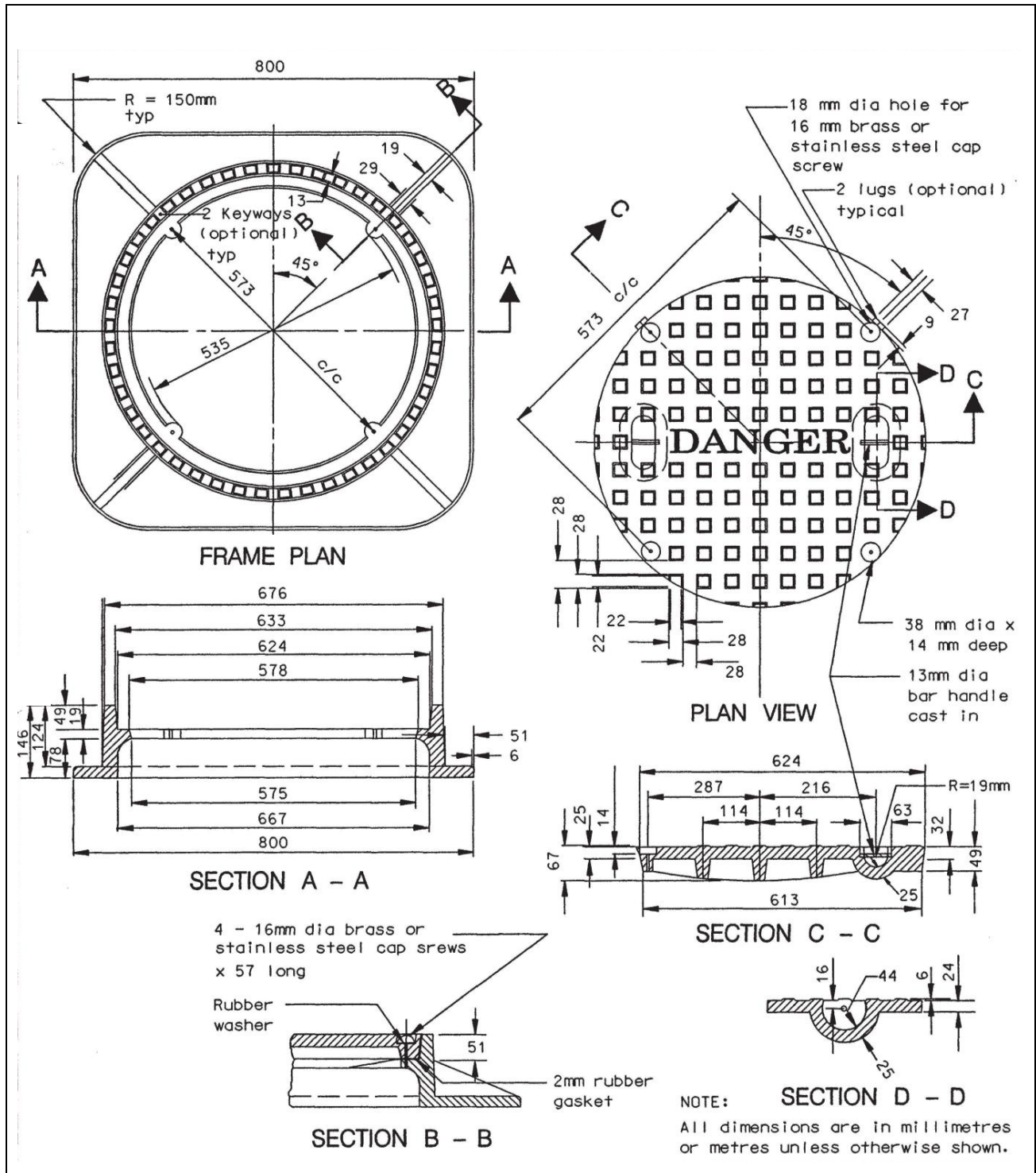

CORPORATION OF MUNICIPALITY OF THAMES CENTRE - STANDARD DRAWING

**Maintenance Hole Cast Iron, Watertight Cover and Square Frame**

REVISION DATE:

NOV 2020

DRAWING #:

**S-7**

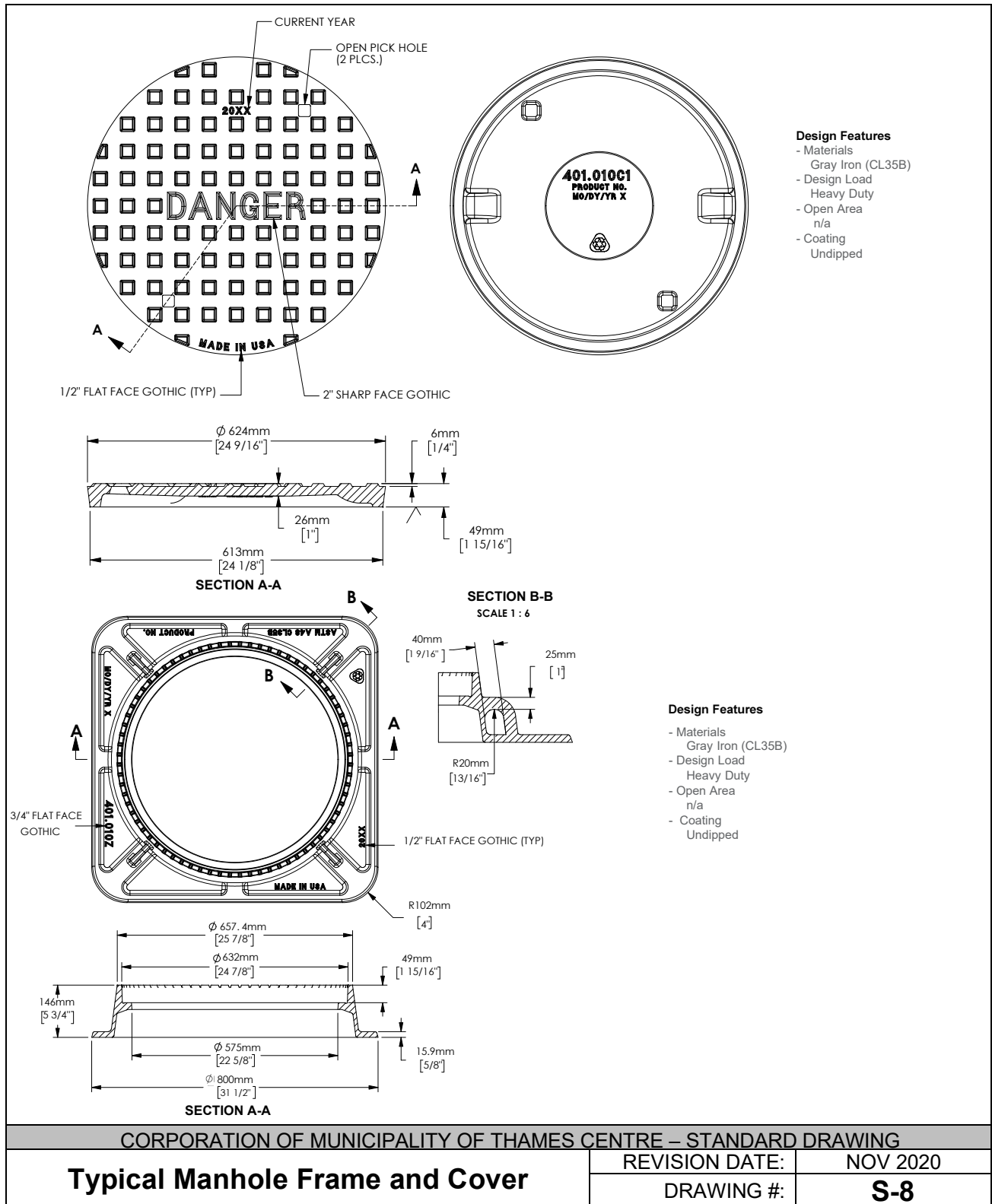

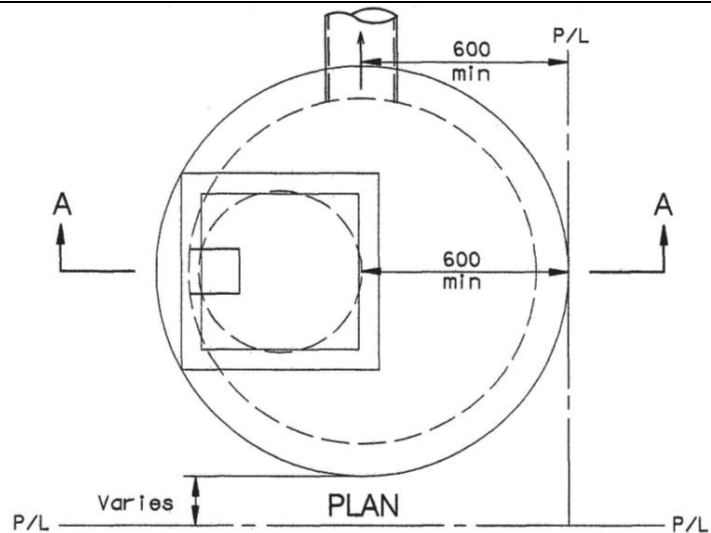

**NOTES:**

1. Outlet hole diameter = 400mm, located as required.
2. Adjustment units and components shall be installed as per OPSD 701.030
3. Class of concrete 30 MPA at 28 days
4. Refer to OPSD 400.02 for CATCH BASIN, CAST IRON FRAME AND FLAT SQUARE GRATE
5. All catchbasin maintenance hole leads and grates are to be located a minimum of 0.6m from the P/L.

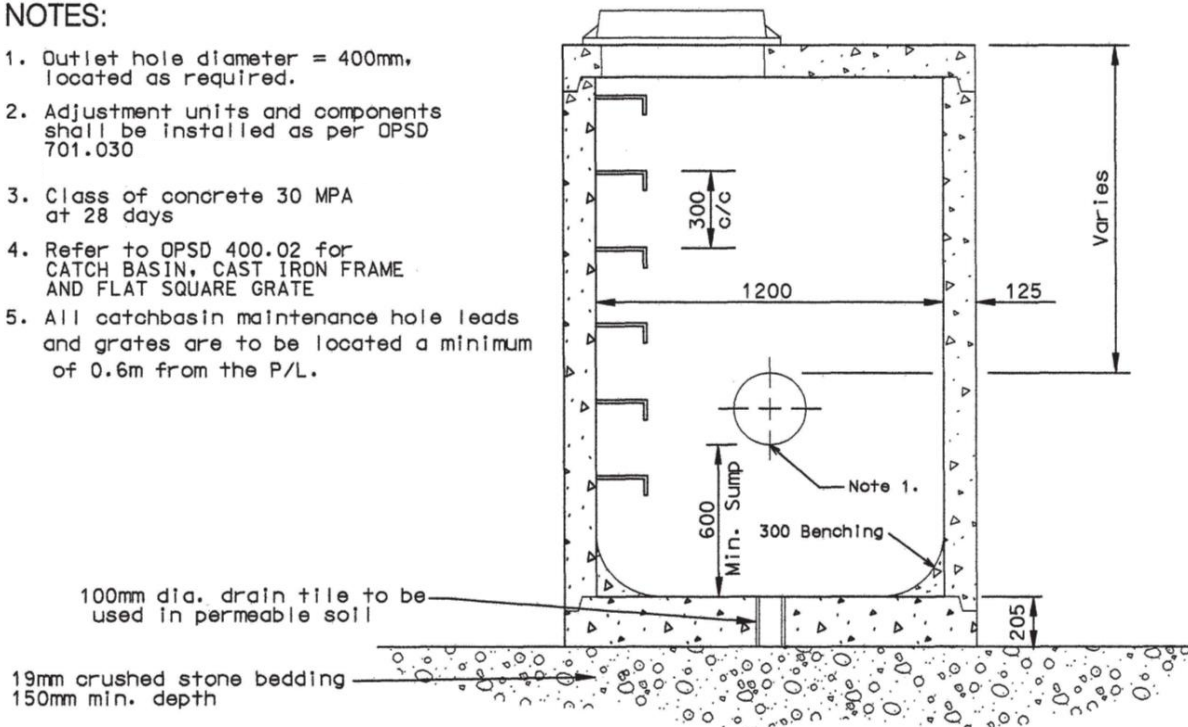

A. ALL DIMENSIONS ARE IN MILLIMETRES UNLESS OTHERWISE SHOWN.

CORPORATION OF MUNICIPALITY OF THAMES CENTRE – STANDARD DRAWING

**Precast Concrete  
Catch Basin – Maintenance Hole**

REVISION DATE:

NOV 2020

DRAWING #:

**S-9**

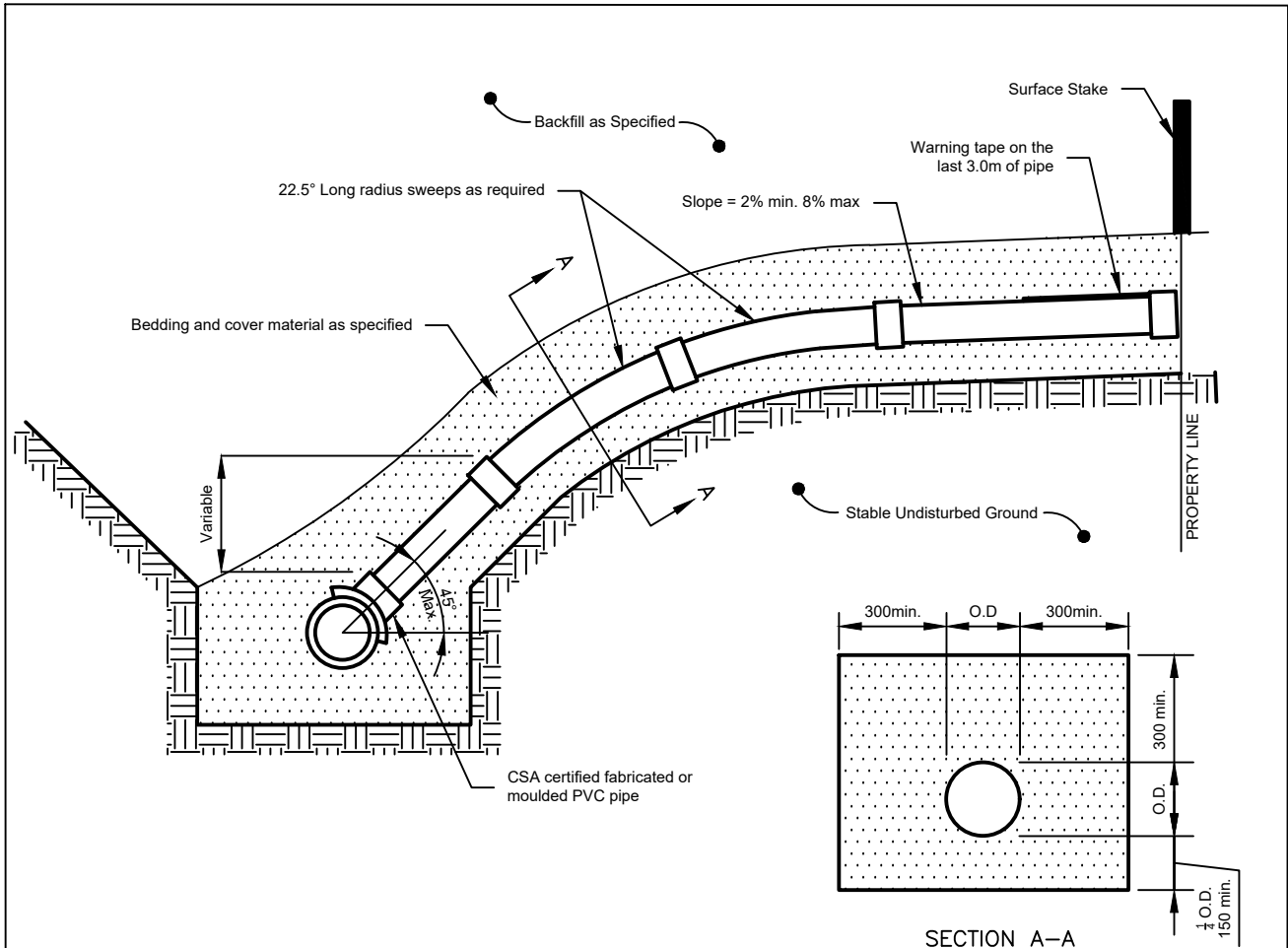

**Notes:**

1. PDC risers are required for sewer depths greater than or equal to 4.5m (see drawing S-11) for details
2. The minimum inside diameter for Sanitary P.D.C is 100mm and Storm P.D.C is 150mm
3. The minimum clearance between a P.D.C and a sewer or watermain (outside wall to outside wall) is 150mm
4. Pre fabricated tees shall be used for all service connections on new sewer main construction, including sewer mains for new subdivisions prior to assumption.
5. Saddle connections may be used when connecting new services to an existing sewer main with the approval of the Director of Public Works
6. No Private Drain Connections to maintenance holes are permitted.
7. Sanitary P.D.C end caps are to be water tight and capable of withstanding test pressures.

CORPORATION OF THE MUNICIPALITY OF THAMES CENTRE - STANDARD DRAWING

<b>Private Drain Connection - Less than 4.5m Depth</b>	REVISION DATE:	JAN 2023
	DRAWING #:	<b>S-10</b>

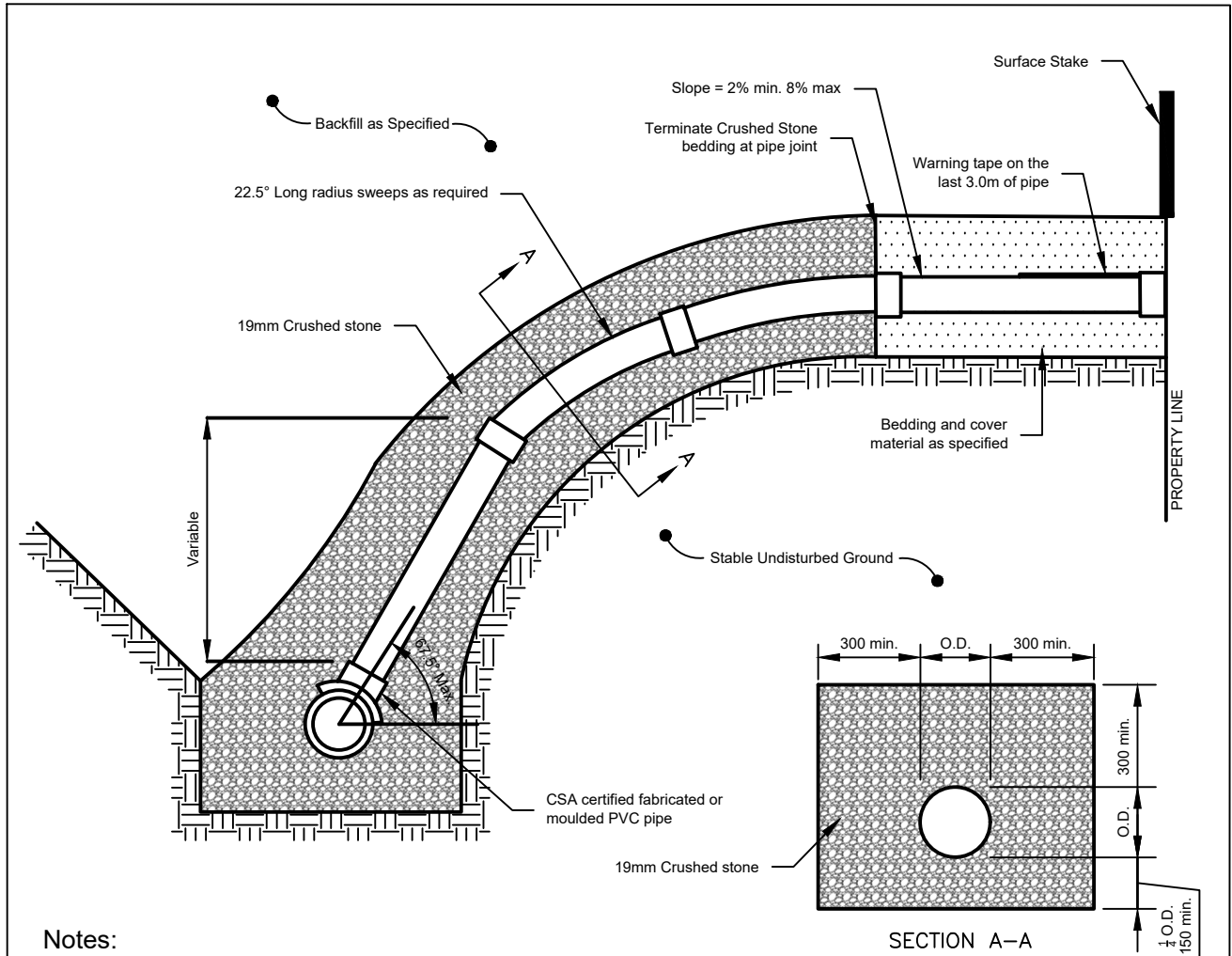

**Notes:**

1. A type 2 P.D.C riser is required for sewer depths greater than or equal to 4.5m from finished grade, and for excavations in stable bank conditions. (See drawing S-10 for sewer depths of less than 4.5m)
2. The minimum inside diameter for Sanitary P.D.C is 100mm and Storm P.D.C is 150mm
3. Prefabricated tees shall be used for all service connections on new sewer main construction, including sewer mains for new subdivisions prior to assumption. Saddle connections may be used when connecting new services to an existing sewer main with the approval of the Director of Public Works
4. No Private Drain Connections to maintenance holes are permitted
5. Where horizontal or vertical bends are required, long radius sweeps shall be used. Short bends are not acceptable
6. Sanitary P.D.C end caps are to be water tight and capable of withstanding test pressures

CORPORATION OF THE MUNICIPALITY OF THAMES CENTRE - STANDARD DRAWING

<b>Private Drain Connection Greater than 4.5m Depth</b>	REVISION DATE:	JAN 2023
	DRAWING #:	<b>S-11</b>

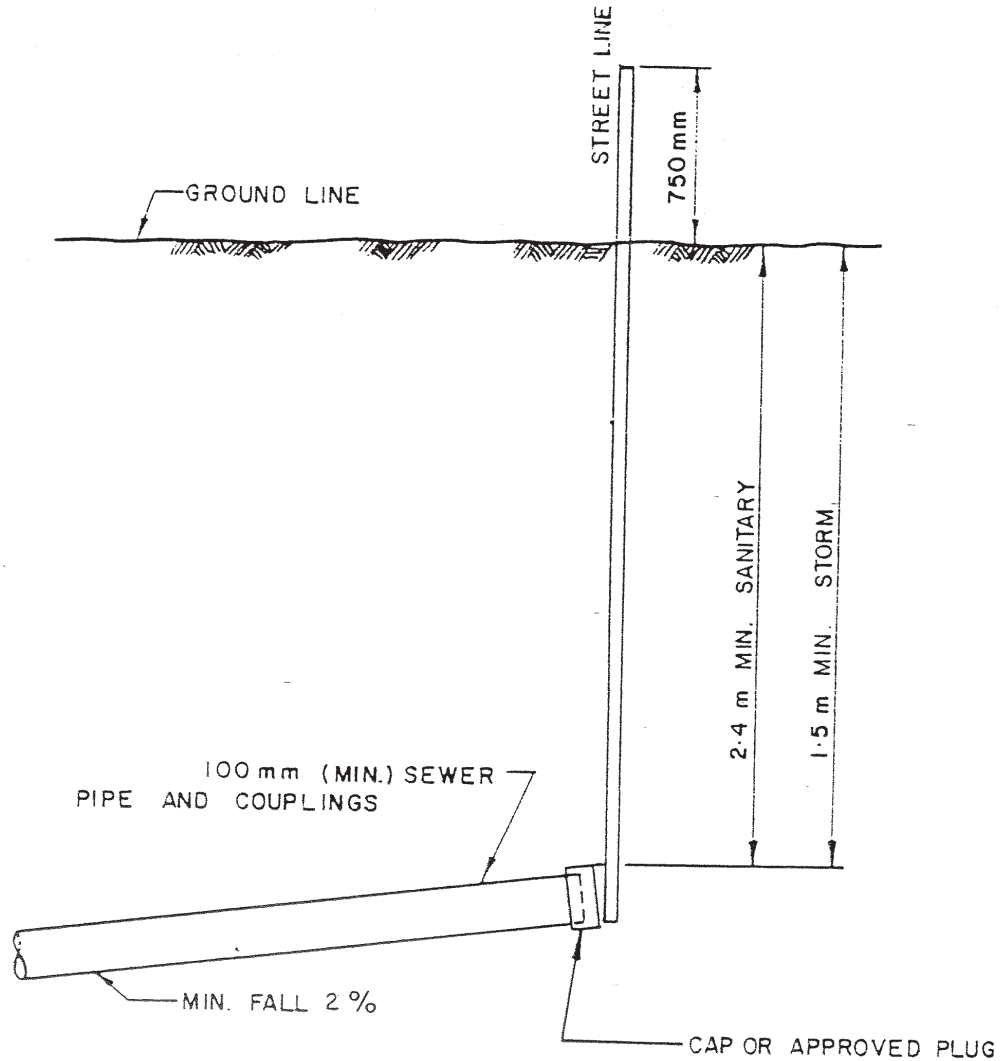

**Notes:**

1. Where applicable, approved and plugs are required at property line to complete the PDC installations. They shall be braced to withstand the pressure testing when required.

CORPORATION OF MUNICIPALITY OF THAMES CENTRE – STANDARD DRAWING

**Private Drain Connection Marker  
(Residential)**

REVISION DATE:

NOV 2020

DRAWING #:

**S-12**

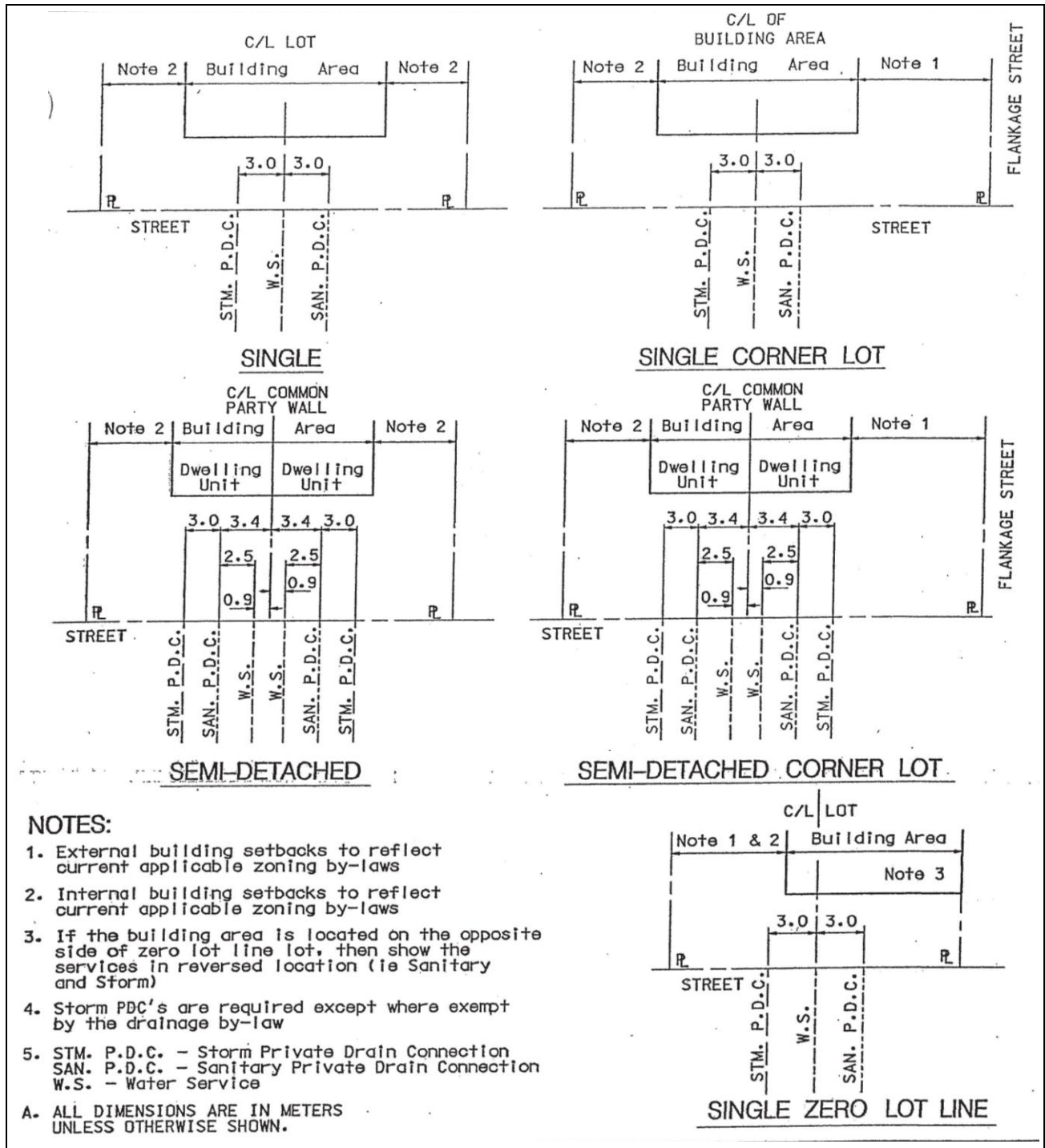

CORPORATION OF MUNICIPALITY OF THAMES CENTRE – STANDARD DRAWING		
<b>Standard Servicing Locations for Single Family and Semi-Detached Lots</b>	REVISION DATE:	NOV 2020
	DRAWING #:	<b>D-1</b>



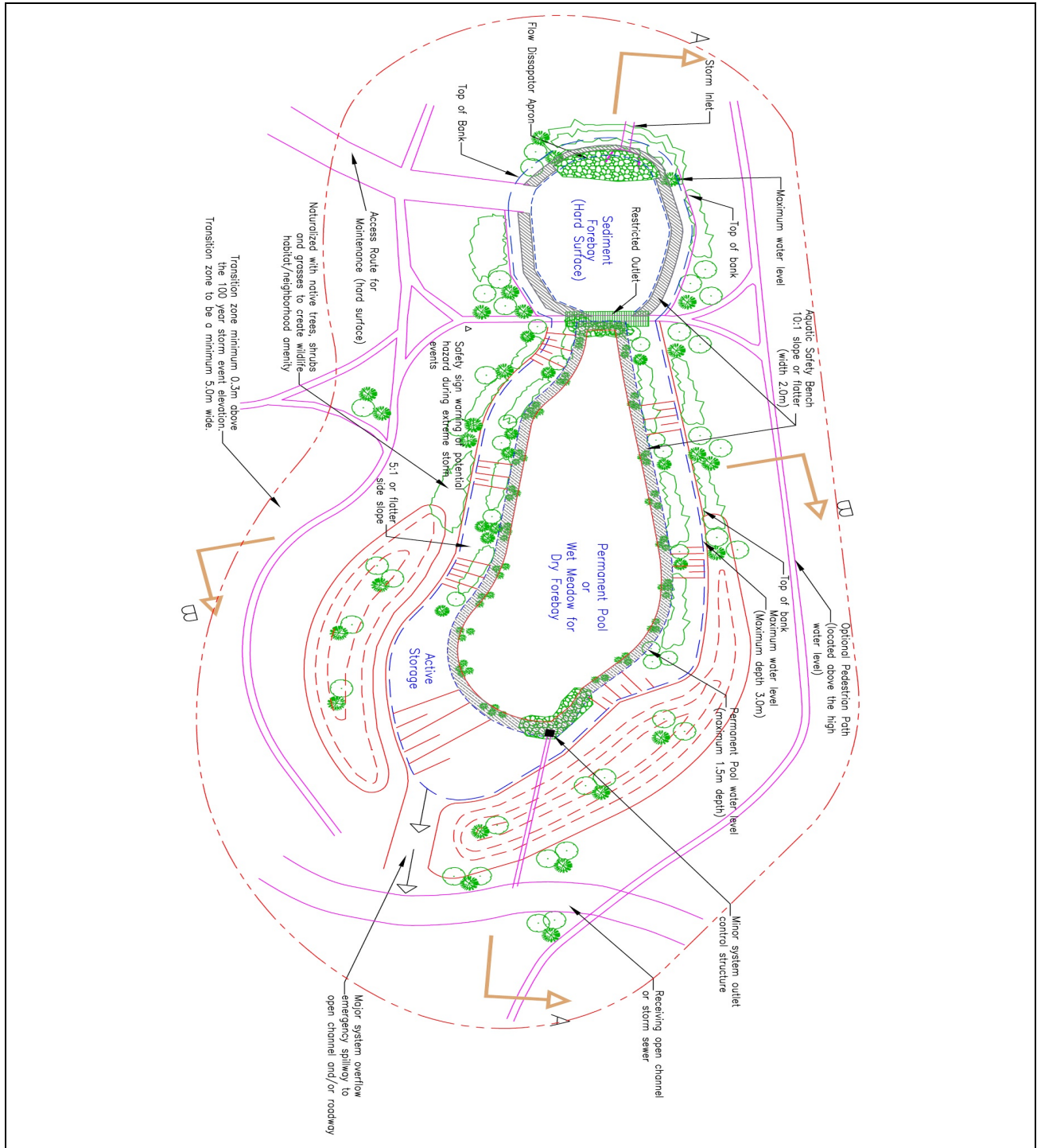

CORPORATION OF MUNICIPALITY OF THAMES CENTRE – STANDARD DRAWING

**Sectional Views of Typical Conceptual Facility Design Wet/Dry/Hybrid**

REVISION DATE:

NOV 2020

DRAWING #:

**D-3**

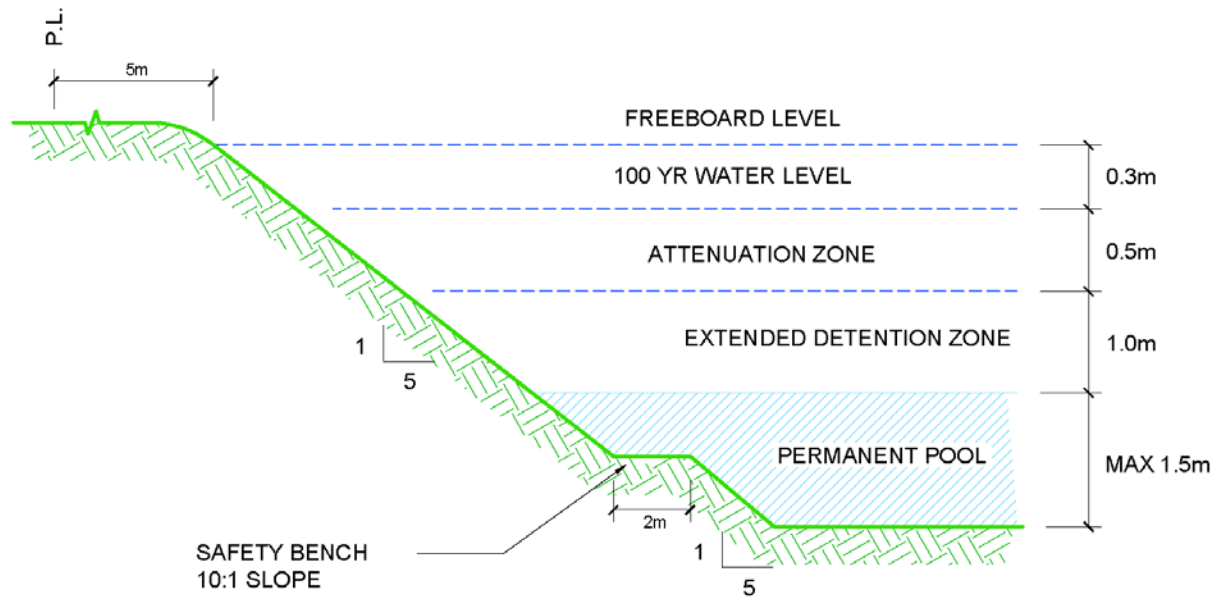

CORPORATION OF MUNICIPALITY OF THAMES CENTRE – STANDARD DRAWING

**Basin Cross-Section Based on Modification of  
the Proposed SWM Requirements**

REVISION DATE:

NOV 2020

DRAWING #:

**D-4**

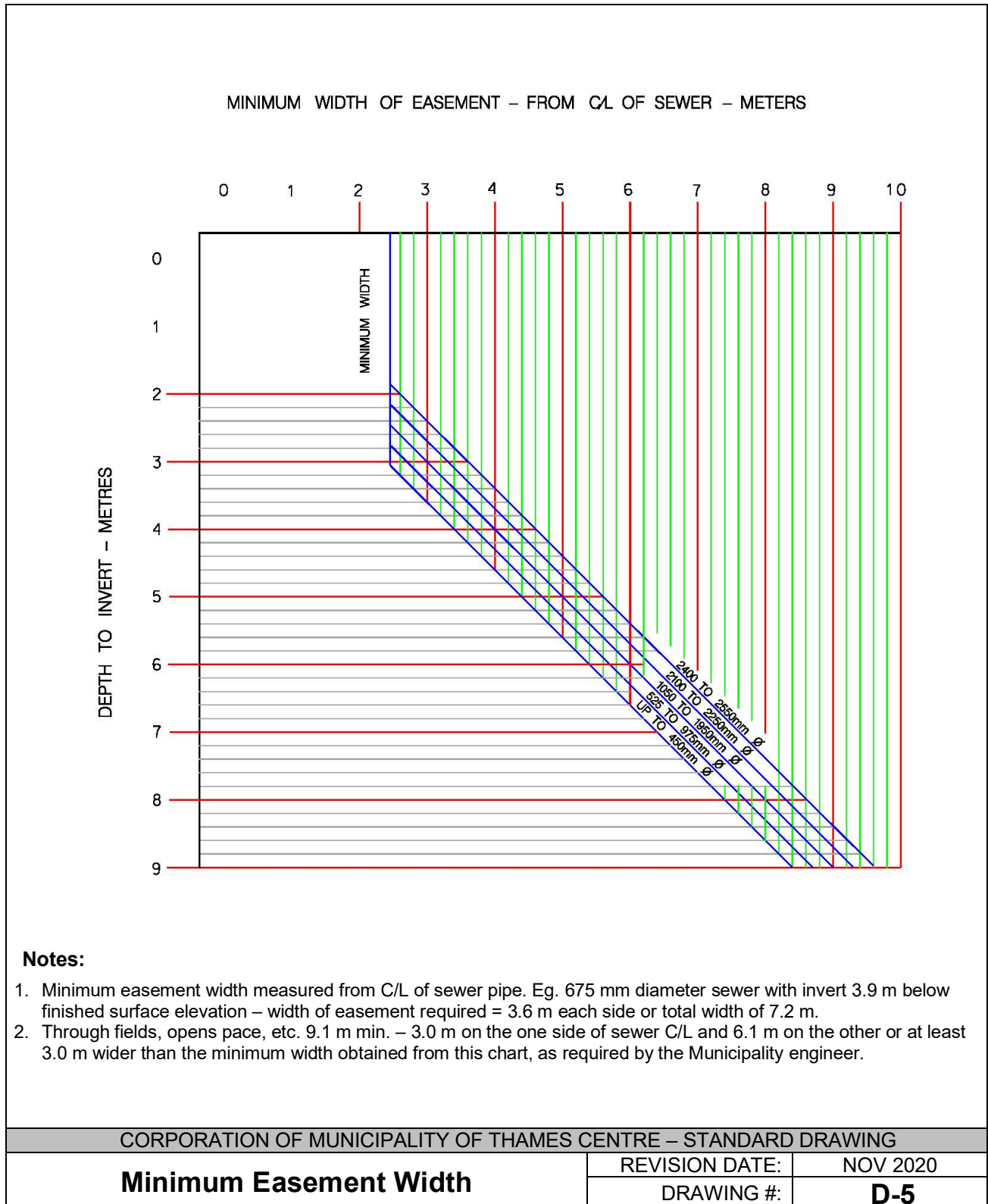

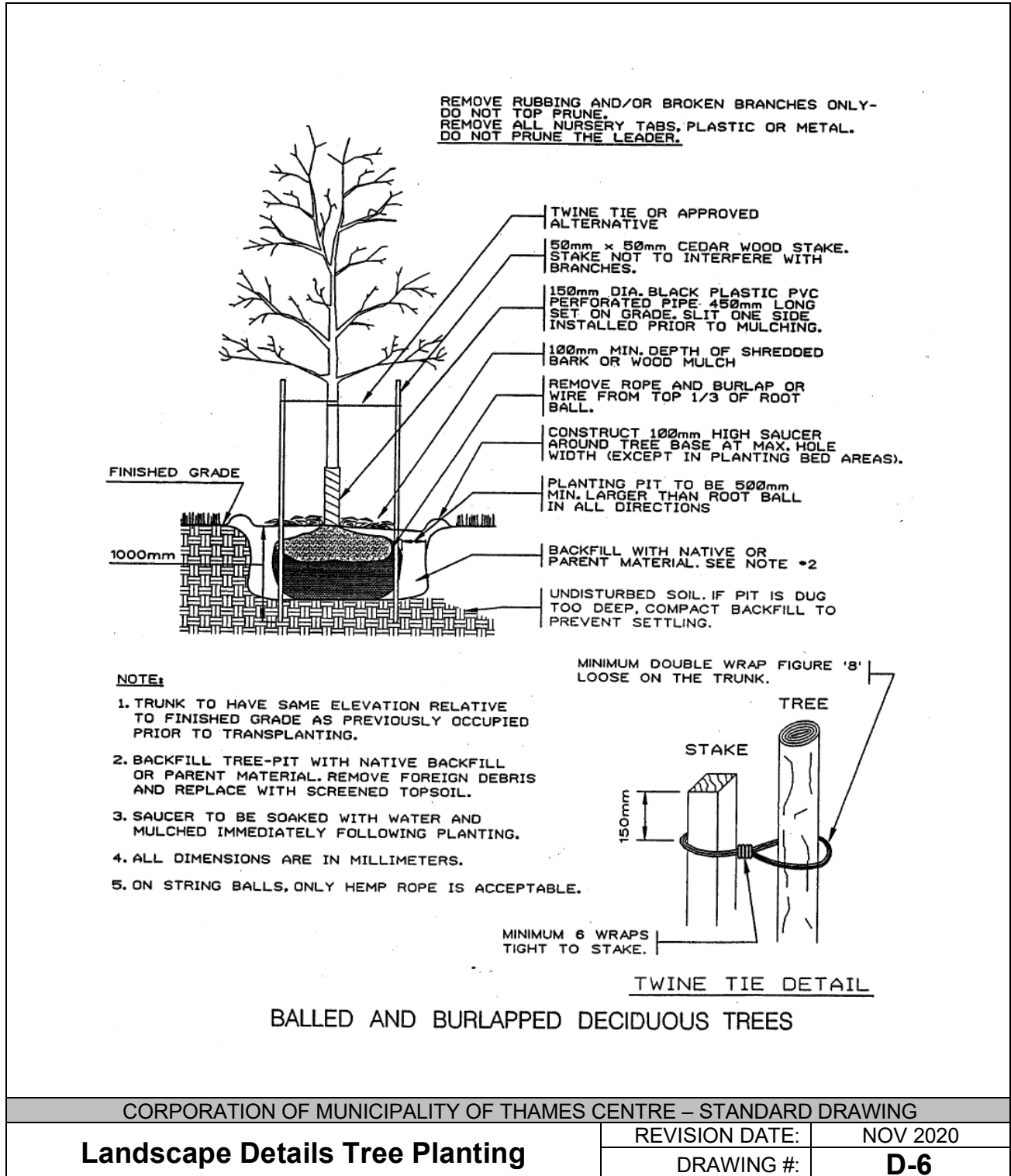

CORPORATION OF MUNICIPALITY OF THAMES CENTRE – STANDARD DRAWING

**Landscape Details Tree Planting**

REVISION DATE:

NOV 2020

DRAWING #:

**D-6**



