

THE CORPORATION OF THE MUNICIPALITY OF THAMES CENTRE

BY-LAW NO. 106-2001

Being a By-law to require the erection and maintenance of fences and gates around privately-owned outdoor swimming pools.

WHEREAS the *Municipal Act, R.S.O. 1992, Chapter M.45 Section 210, paragraph 30*, empowers a Municipal Council to pass By-laws and regulations respecting the erection of fences enclosing outdoor privately-owned swimming pools;

AND WHEREAS the Council of The Municipality of Thames Centre deems it necessary to pass such a By-law to regulate fences enclosing privately-owned outdoor swimming pools;

NOW THEREFORE the Council of The Corporation of the Municipality of Thames Centre enacts as follows:

1. DEFINITIONS

- a) "Privately Owned Outdoor Swimming Pool" shall mean any swimming pool located on private property under the control of the owner or the occupant, the use of which is limited to swimming or bathing by members of the owner's family or their visitors.
 - b) "Swimming Pool" shall mean any body of water located outdoors on privately owned property, contained in whole by artificial means, in which the depth of the water at any point can exceed 610 mm (24 inches), and has a surface area greater than 1 square metre (10.8 square feet), and used or capable of being used for swimming, bathing or diving.
 - c) "Fence" shall mean a wall, structure or building which meets the structural requirements of this By-law for enclosing a swimming pool and "enclosure" has a corresponding meaning;
 - d) "Maintenance Gate" shall mean any gate larger than 1 metre (39 inches) in width
 - e) "Self-closing Device" shall mean a mechanical device or spring which returns a gate to its closed position within 10 seconds after it has opened.
 - f) "Self-latching Device" shall mean a mechanical device or latch which is engaged each time the gate it secures is closed; a self-latching device must not allow the gate to be opened by pushing or pulling, it must remain closed until unlatched by lifting or turning the device itself either directly or by a key;
 - g) "Chief Building Official" shall mean the person appointed by the Council to such position pursuant to the Building Code Act;
2. No person shall erect a fence or gate for a swimming pool until the plans for such fences and gates have been submitted to the Chief Building Official and a permit to erect the fence has been issued.
3. No person shall excavate for, or erect, a privately owned swimming pool without a swimming pool fence permit issued by the Chief Building Official.
4. No person shall maintain a privately owned outdoor swimming pool in the Municipality of Thames Centre unless such swimming pool or land or the part of the land on which such pool is located, is effectively fenced in accordance with the following provisions:
- a) Every fence shall be a minimum of 48" in height and shall be either of a close-boarded, fibreglass, steel, aluminum, or chain-link type fence with construction/erection being as set forth in Schedule "A" attached hereto and forming a part of this By-law;
 - b) Every fence shall be so constructed as not to have openings, holes or gaps larger than four (4) inches in its shortest dimensions;
 - c) Every fence shall be so constructed so that it is non-climbable and all horizontal or diagonal structural members of the fence shall be located on the inside (poolside) of the fence;
 - d) A wall of a building may be considered a part of the required fence when substituted for any portion of the fence. That portion of the building wall must be continuous with, and directly attached to, the security fence around the pool;

- e) Every fence shall be so constructed so as to have the only means of entry by gates or doors (entrances from dwelling units excluded):
 - i) All gates or doors shall be equipped with a self-closing device and a self-latching device on the pool side at the top of the gate to the extent that all gates or doors will remain securely closed when not in use;
 - ii) All "maintenance gates" shall remain locked at all times; and
 - iii) All gates shall comply with the provisions contained in Section 4 (a), (b), (c) and (d) of this By-law.
 - f) The type of fence commonly known as "snowfencing" shall not be considered as a permanent fence under this By-law but, shall be erected and maintained during construction; and
 - g) The location of such swimming pool must be in accordance with the relevant provisions of the current Municipality of Thames Centre Zoning By-law.
5. The provisions of this By-law shall apply to all privately owned swimming pools regardless of the date of construction of such swimming pool.
 6. Every person is prohibited from placing water in any privately owned outdoor swimming pool or allowing water to remain therein unless the prescribed fence and gates have been erected.
 7. Any person who contravenes any provisions of this By-law is guilty of an offence and shall upon conviction be liable to a fine recoverable under the Provincial Offences Act.
 8. Should any section of the By-law, including any part of the Schedules, be declared by a court of competent jurisdiction to be ultra vires, the remaining parts shall nevertheless remain valid and binding and shall be read as if the offending section had been struck out.
 9. This By-law shall repeal current Township of North Dorchester By-law No. 33-93 and Township of West Nissouri By-law No. 8-90.
 10. This By-law shall come into force and take effect upon the final reading thereof.

READ a FIRST and SECOND time this 22nd day of October, 2001.

READ a THIRD time and **FINALLY PASSED** this 22nd day of October, 2001.

BY LAW INDEX	
Fencing	✓
Swimming Pools	✓

A. J. Marr
Mayor, A. Marr

M. Casavecchia
Clerk, M. Casavecchia

SCHEDULE

"A"

TO

BY-LAW No. 106-2001

SWIMMING POOL FENCES

This is Schedule "A" which sets forth the specifications for the erection of swimming pool fences.

a) Detail of fence construction

i) Close-Boarded Wooden Fence

Vertical boarding, spaced not more than 4" apart and fixed to two horizontal rails on the inside, supported by 4" x 4" posts at 8'0" maximum centres.

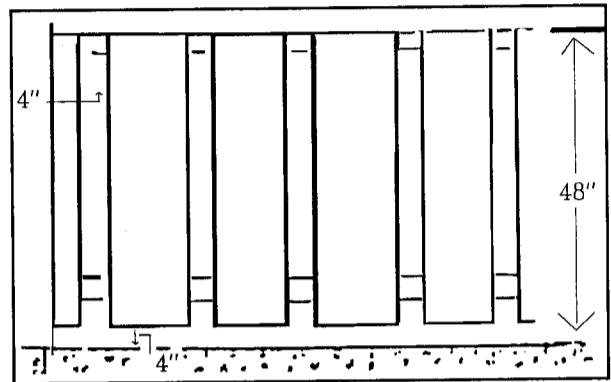

(ii) Chain Link Fence

2" max, diamond mesh chain link made of either 9 gauge min. galvanized wire or 12 gauge wire with a coating, supported at 10'0" max. centres by 1½" minimum diameter galvanized posts set into concrete.

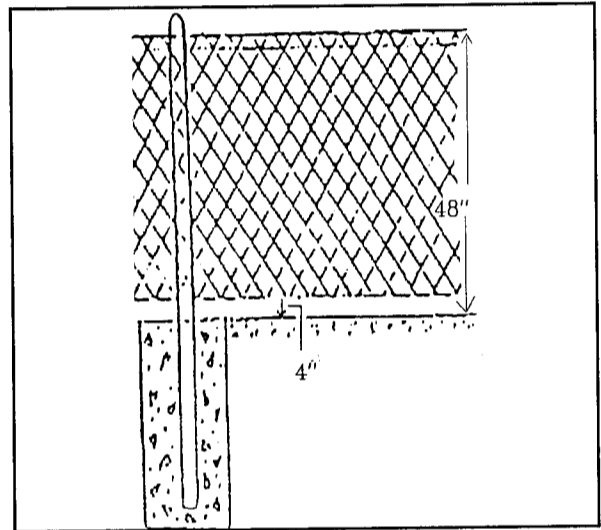

b) ABOVE-GROUND POOLS: where security fence NOT REQUIRED

(i) Above-Ground Pools with a self-contained deck and railing, deck floor not less than 48" above ground.

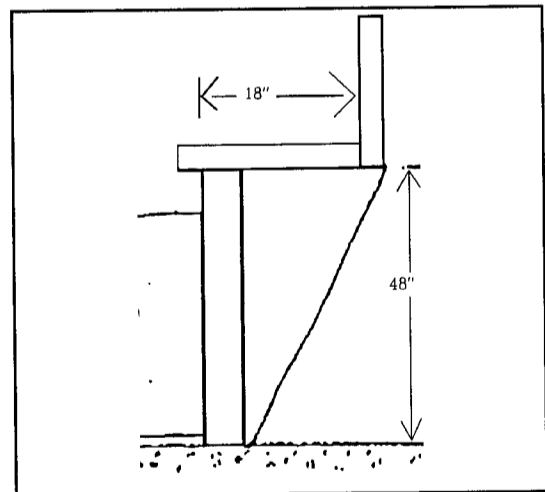

(ii) Above-Ground pools where the side wall is not less than 48" above ground level and the pool has a controllable access (i.e. - removable or flip-up ladders/stairs).

